

## 0.8mm Height Flat Top Phototransistor

### EAPSR3216A1

#### Features

- Fast response time
- High photo sensitivity
- Small junction capacitance
- Pb free
- The product itself will remain within RoHS compliant version.

#### Descriptions

- EAPSR3216A1 is a phototransistor in miniature SMD package which is molded in a black with spherical top view lens. The device is Spectrally matched to visible and infrared emitting diode.

#### Applications

- Miniature switch
- Counters and sorter
- Position sensor
- Infrared applied system
- Encoder

#### Device Selection Guide

Part Category	Chip Material	Lens Color
EAPSR3216A1	Silicon	Black

**Package Dimensions**

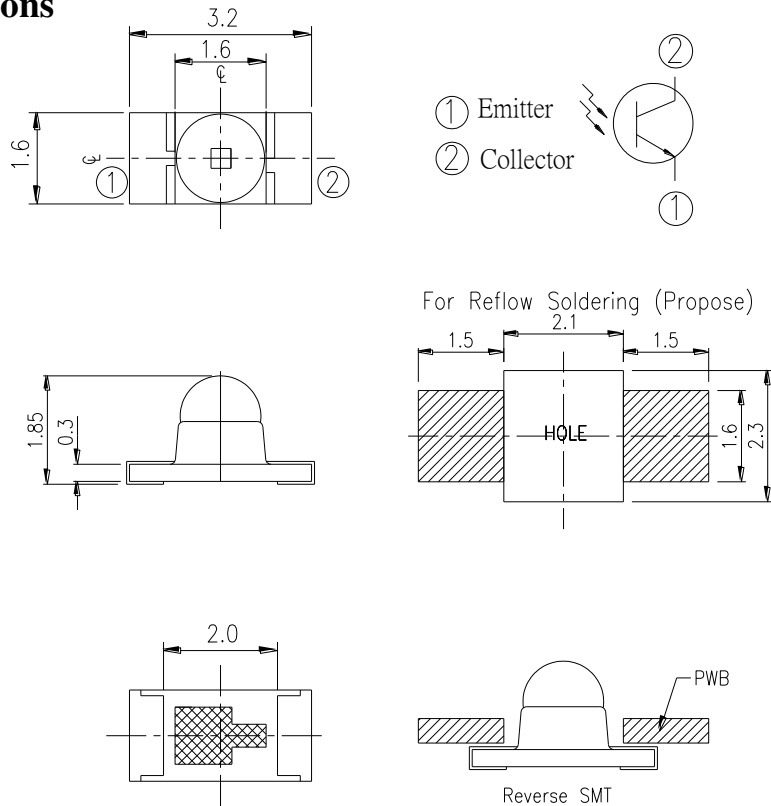

- Notes:** 1.All dimensions are in millimeters  
 2.Tolerances unless dimensions  $\pm 0.1\text{mm}$

**Absolute Maximum Ratings (Ta=25°C)**

Parameter	Symbol	Rating	Units
Collector-Emitter Voltage	$V_{CEO}$	30	V
Emitter-Collector-Voltage	$V_{ECO}$	5	V
Collector Current	$I_C$	20	mA
Operating Temperature	$T_{opr}$	-25 ~ +85	°C
Storage Temperature	$T_{stg}$	-40 ~ +85	°C
Soldering Temperature *1	$T_{sol}$	260	°C
Power Dissipation at(or below) 25°C Free Air Temperature	$P_d$	75	mW

**Notes:** \*1:Soldering time  $\leq 5$  seconds.

**Electro-Optical Characteristics (Ta=25°C)**

Parameter	Symbol	Condition	Min	Typ	Max	Unit
Rang Of Spectral Bandwidth	$\lambda_{0.5}$	---	730	---	1100	nm
Wavelength Of Peak Sensitivity	$\lambda_P$	---	---	940	---	nm
Collector-Emitter Breakdown Voltage	$BV_{CEO}$	$I_C=500 \mu A$ $E_e=0mW/cm^2$	60	---	---	V
Emitter-Collector Breakdown Voltage	$BV_{ECO}$	$I_E=50 \mu A$ $E_e=0mW/cm^2$	7	---	---	V
Collector-Emitter Saturation Voltage	$V_{CE(sat)}$	$I_C=5mA$ $E_e=1m W/cm^2$	---	---	0.4	V
Collector Dark Current	$I_{CEO}$	$V_{CE}=10V$ $E_e=0mW/cm^2$	---	---	50	nA
On State Collector Current	$I_{C(ON)}$	$V_{CE}=5V$ $E_e=1mW /cm^2$	---	1.0	---	mA

**Typical Electro-Optical Characteristics Curves**

Fig.1 Spectral Sensitivity

Fig.2 Collector Current vs. Irradiance

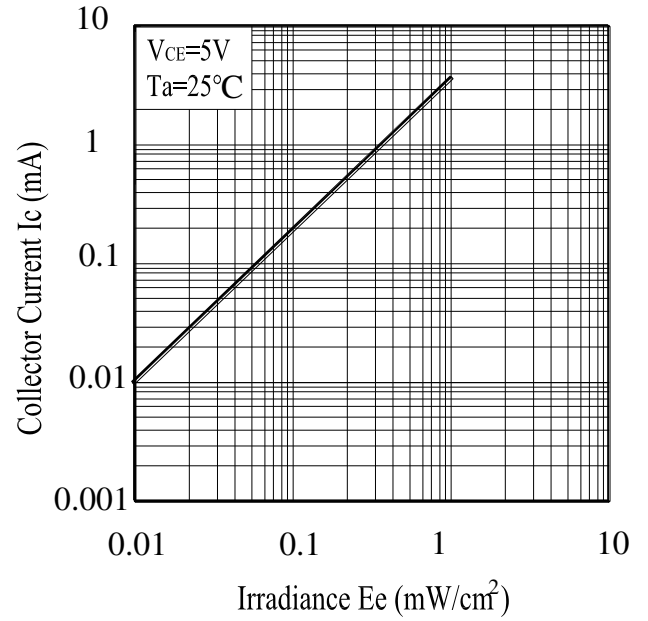
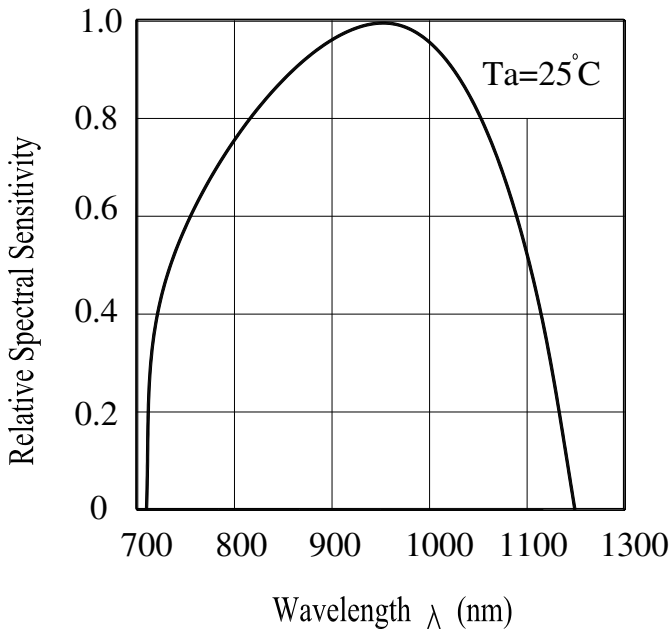
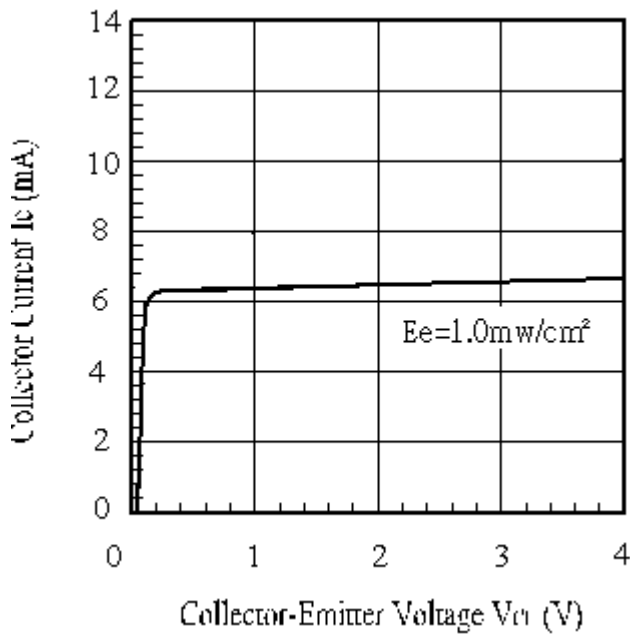

Fig.3 Collector Current vs. Collector-Emitter Voltage



## Precautions For Use

### 1. Over-current-proof

Customer must apply resistors for protection , otherwise slight voltage shift will cause big current change ( Burn out will happen ).

### 2. Storage

2.1 Do not open moisture proof bag before the products are ready to use.

2.2 Before opening the package, the LEDs should be kept at 30°C or less and 90%RH or less.

2.3 The LEDs should be used within a year.

2.4 After opening the package, the LEDs should be kept at 30°C or less and 60%RH or less.

2.5 The LEDs should be used within 168 hours (7 days) after opening the package.

2.6 If the moisture absorbent material (silica gel) has faded away or the LEDs have exceeded the storage time, baking treatment should be performed using the following conditions.

Baking treatment :  $60\pm 5^{\circ}\text{C}$  for Min. 24 hours.

### 3. Soldering Condition

#### 3.1 Pb-free solder temperature profile

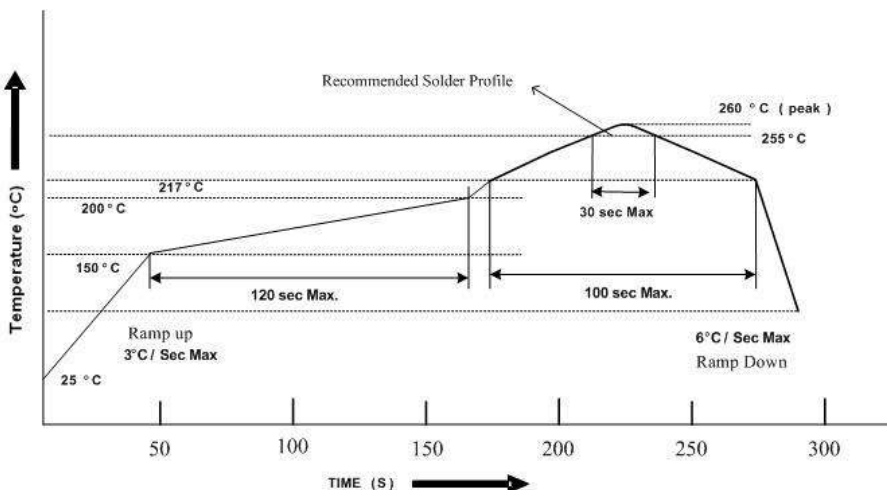

3.2 Reflow soldering should not be done more than two times.

3.3 When soldering, do not put stress on the LEDs during heating.

3.4 After soldering, do not warp the circuit board.

#### 4.Soldering Iron

Each terminal is to go to the tip of soldering iron temperature less than  $350^{\circ}\text{C}$  for 3 seconds within once in less than the soldering iron capacity 25W. Leave two seconds and more intervals, and do soldering of each terminal. Be careful because the damage of the product is often started at the time of the hand solder.

#### 5.Repairing

Repair should not be done after the LEDs have been soldered. When repairing is unavoidable, a double-head soldering iron should be used (as below figure). It should be confirmed beforehand whether the characteristics of the LEDs will or will not be damaged by repairing.

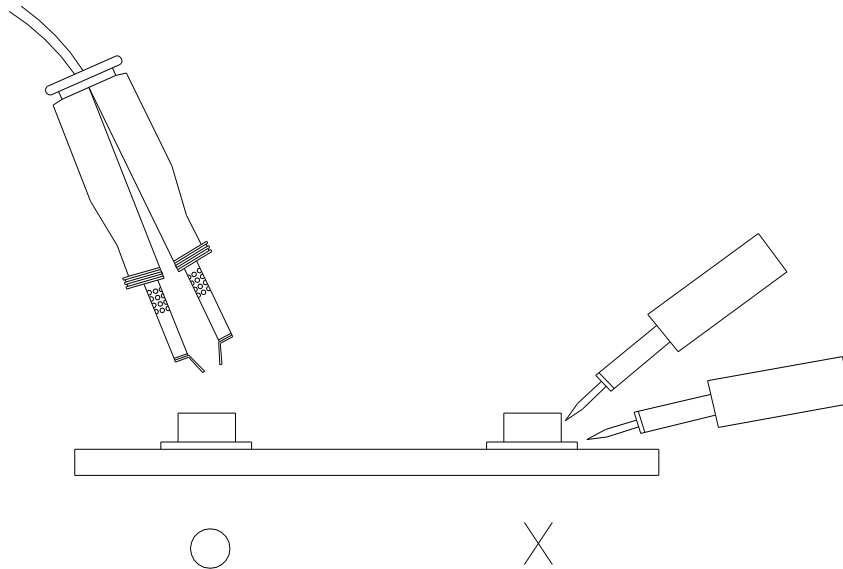

**Package Dimensions**

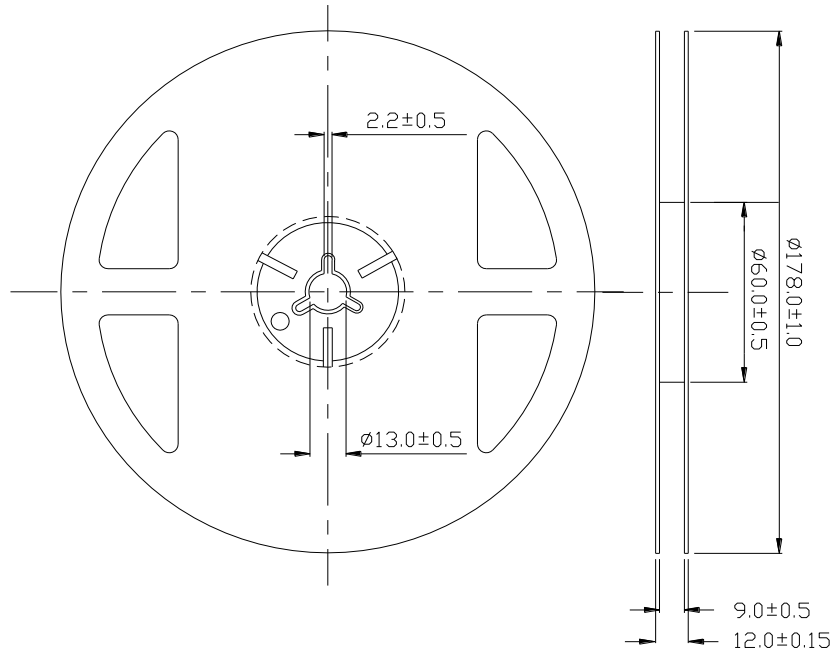

Note: The tolerances unless mentioned are  $\pm 0.1$ , unit=mm

**Carrier Taping Dimensions: (Quantity: 1500PCS/Reel)**

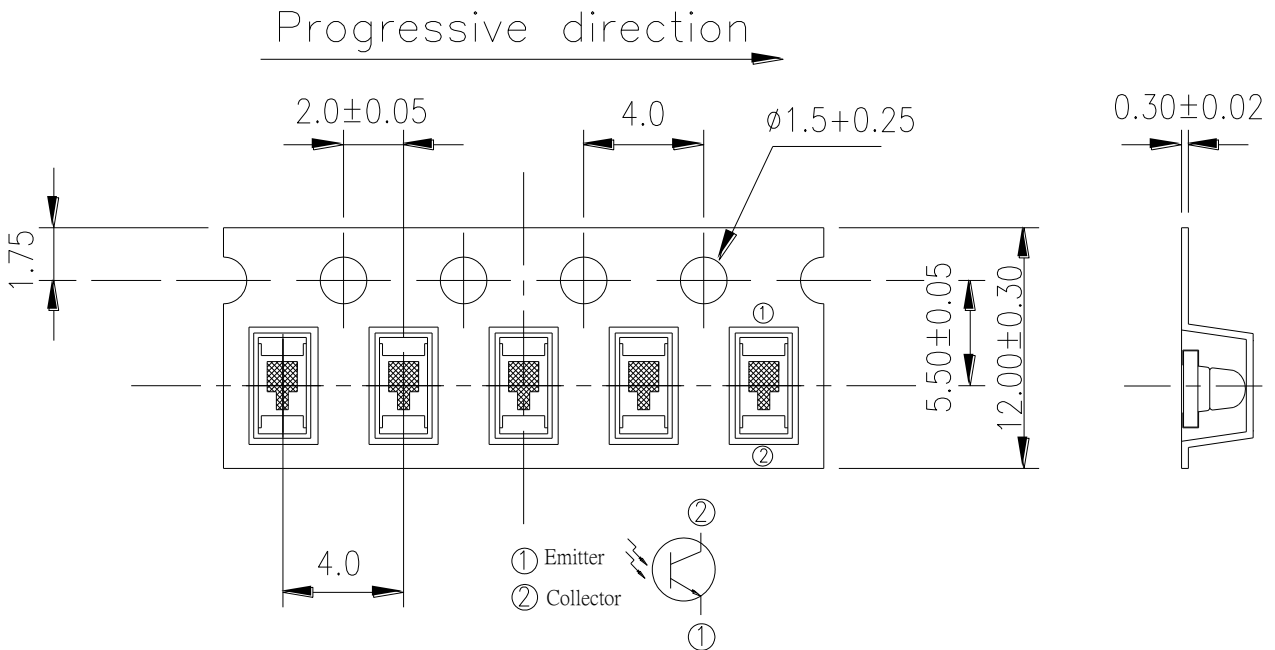

Note: The tolerances unless mentioned are  $\pm 0.1$ , unit=mm

### Packing Procedure

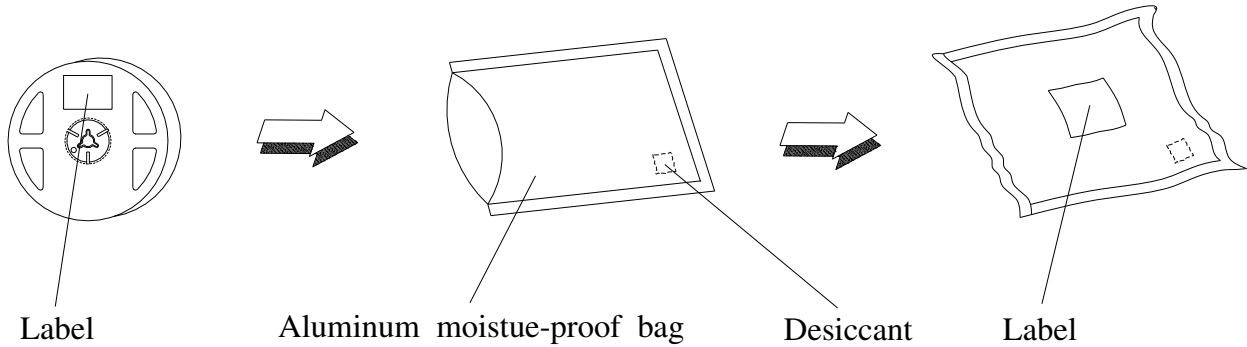

### Label Form Specification

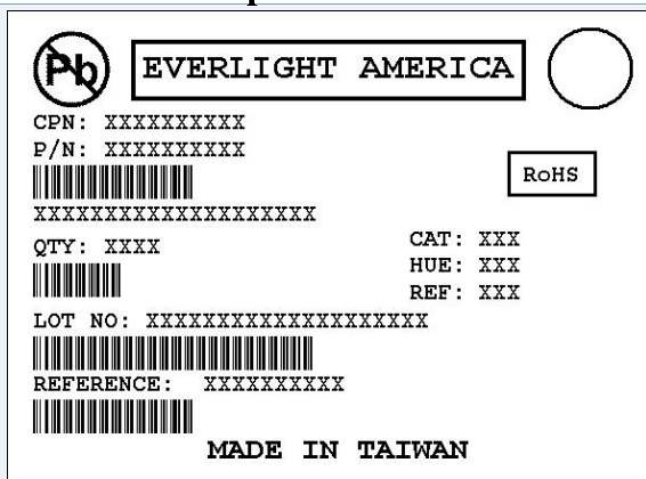

CPN: Customer's Production Number  
 P/N : Production Number  
 QTY: Packing Quantity  
 CAT: Ranks  
 HUE: Peak Wavelength  
 REF: Reference  
 LOT No: Lot Number

### Notes

1. Above specification may be changed without notice. Everlight Americas will reserve authority on material change for above specification.
2. When using this product, please observe the absolute maximum ratings and the instructions for using outlined in these specification sheets. Everlight Americas assumes no responsibility for any damage resulting from use of the product which does not comply with the absolute maximum ratings and the instructions included in these specification sheets.
3. These specification sheets include materials protected under copyright of Everlight Americas corporation. Please don't reproduce or cause anyone to reproduce them without Everlight Americas's consent.