

PART NUMBER	PLATING
75545-5000	30μ INCH MIN SELECT HARD GOLD IN CONTACT AREA WITH 100μ INCH MIN SELECT TIN IN TAIL AREA OVER 50μ INCH MIN NICKEL OVERALL

- NOTES:
- MATERIALS:
    - HOUSING: 30% GLASS FILLED, LCP 94V-0, COLOR: BLACK
    - TERMINALS: COPPER ALLOY
    - PLATING: PER ES-88 - SEE CHART
    - LUBRICATION: EB1 IN CONTACT AREA
  - SEE CHART FOR REFERENCE DOCUMENTS
  - RECEPTACLE MATES WITH PLUG ASSEMBLIES: 75561-5000, 75561-5001, 75561-1500 & 75561-1501
  - AVERAGE INSERTION FORCE INTO PCB IS 8.2 Kg/18 LBS PER TAIL
  - MODULE ASSEMBLY IS RoHS COMPLIANT
  - GATHERABILITY: ±0.65/.026 X-DIRECTION  
±1.30/.051 Y-DIRECTION
  - TERMINAL RETENTION INTO HOUSING .45Kg/1.0 LB

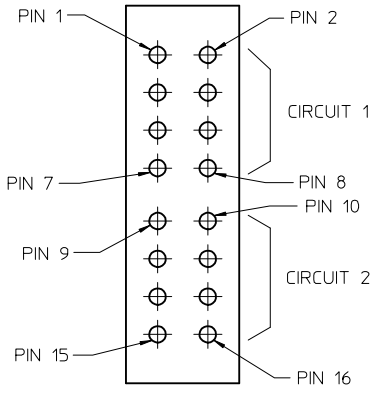
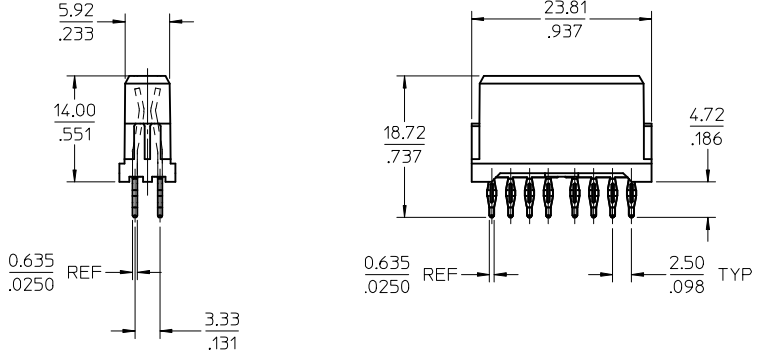
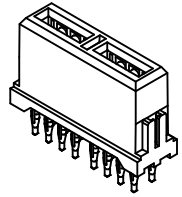
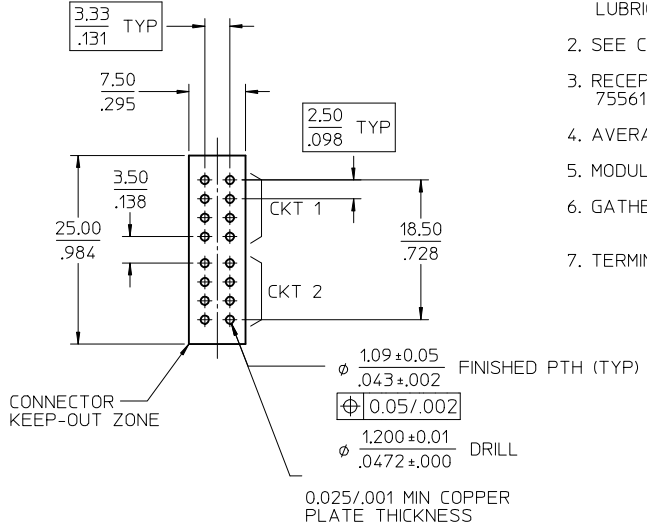
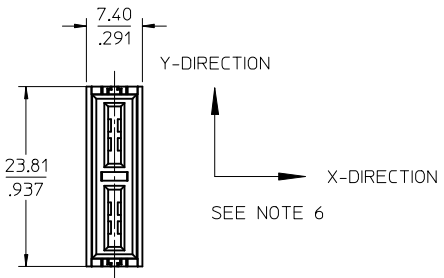

REFERENCE DOCUMENTS	
PS-75431-999	PRODUCT SPECIFICATION: PERFORMANCE AND RATINGS
SD-75541-***	MODULE CONFIGURATION DRAWING
AS-75541-0000	APPLICATION SPECIFICATION

REMOVED P/N FROM CHART EC NO: UCP2014-1914 DRWN: JUILLES 2013/10/30 CHKD: MBANDURA 2013/10/30 APATEL 2013/11/17	QUALITY SYMBOLS	GENERAL TOLERANCES (UNLESS SPECIFIED)	DIMENSION STYLE	SCALE	DESIGN UNITS	THIRD ANGLE PROJECTION	
	▽=0	mm INCH	MM/IN	2:1	METRIC		
	▽=0	4 PLACES ± --- ± --- 3 PLACES ± --- ± .008 2 PLACES ± 0.20 ± .013 1 PLACE ± 0.33 ± ---	DRAWN BY DATE AD RATNOL 2005/04/19	TITLE	<b>POWERMASS 80 AMP MODULE RECEPTACLE</b>		
	▽=0	ANGULAR ±1/2°	CHECKED BY DATE MDATA 2005/04/19				
REV: A6	DRAFT WHERE APPLICABLE MUST REMAIN WITHIN DIMENSIONS	APPROVED BY DATE APATEL 2005/04/19	MATERIAL NO. <b>SEE CHART</b>	DOCUMENT NO. <b>SD-75545-100</b>	<b>MOLEX INCORPORATED</b>		
			SIZE C	THIS DRAWING CONTAINS INFORMATION THAT IS PROPRIETARY TO MOLEX INCORPORATED AND SHOULD NOT BE USED WITHOUT WRITTEN PERMISSION			