

Product Specification

DWDM 2.7G SFP Transceiver

FWLF1632xx

PRODUCT FEATURES

- Hot-pluggable SFP footprint
- Up to 2.7 Gb/s data rates
- 100GHz DWDM ITU Grid, C-Band
- Low dispersion DFB laser with 120km reach performance
- Extended link budget with APD receiver technology
- -5°C to 70°C operating case temp.
- Wavelength controlled within $\pm 0.1\text{nm}$ over life and temperature



APPLICATIONS

- Amplified DWDM & SONET networks
- Bandwidth aggregation
- Ring topologies with fixed and reconfigurable OADMs

Finisar's FWLF1632xx transceivers are Small Form Factor Pluggable¹ SFP transceivers designed for use in Dense Wavelength-Division Multiplexing (DWDM) links, for up to 120km link lengths and up to 2.7G bit rates.

The FWLF1632xx SFP transceivers are designed for service providers deploying SONET² and DWDM networking equipment in metropolitan access and core networks, and they are also compatible to Gigabit Ethernet data rate.

The optical transceiver is compliant per the RoHS Directive 2011/65/EU. See Finisar Application Note AN-2038 for more details.^{3,4} Basic digital diagnostic features are implemented as described in Finisar Application Note AN-2030⁵. Enhanced diagnostic features are available as described in the DWDM SFP MSA⁶.

PRODUCT SELECTION

FWLF1632xx

xx: 100GHz ITU Grid channel/wavelength
(please see also next page)

Ordering Information

Product Code	Frequency (THz)	Center Wavelength (nm)
FWLF163217	191.7	1563.86
FWLF163218	191.8	1563.05
FWLF163219	191.9	1562.23
FWLF163220	192.0	1561.42
FWLF163221	192.1	1560.61
FWLF163222	192.2	1559.79
FWLF163223	192.3	1558.98
FWLF163224	192.4	1558.17
FWLF163225	192.5	1557.36
FWLF163226	192.6	1556.55
FWLF163227	192.7	1555.75
FWLF163228	192.8	1554.94
FWLF163229	192.9	1554.13
FWLF163230	193.0	1553.33
FWLF163231	193.1	1552.52
FWLF163232	193.2	1551.72
FWLF163233	193.3	1550.92
FWLF163234	193.4	1550.12
FWLF163235	193.5	1549.32
FWLF163236	193.6	1548.51
FWLF163237	193.7	1547.72
FWLF163238	193.8	1546.92
FWLF163239	193.9	1546.12
FWLF163240	194.0	1545.32
FWLF163241	194.1	1544.53
FWLF163242	194.2	1543.73
FWLF163243	194.3	1542.94
FWLF163244	194.4	1542.14
FWLF163245	194.5	1541.35
FWLF163246	194.6	1540.56
FWLF163247	194.7	1539.77
FWLF163248	194.8	1538.98
FWLF163249	194.9	1538.19
FWLF163250	195.0	1537.40
FWLF163251	195.1	1536.61
FWLF163252	195.2	1535.82
FWLF163253	195.3	1535.04
FWLF163254	195.4	1534.25
FWLF163255	195.5	1533.47
FWLF163256	195.6	1532.68
FWLF163257	195.7	1531.90
FWLF163258	195.8	1531.12
FWLF163259	195.9	1530.33
FWLF163260	196.0	1529.55
FWLF163261	196.1	1528.77

I. Pin Descriptions

Pin	Symbol	Name/Description	Ref.
1	V _{EET}	Transmitter Ground (Common with Receiver Ground)	1
2	T _{FAULT}	Transmitter Fault	
3	T _{DIS}	Transmitter Disable. Laser output disabled on high or open	2
4	MOD_DEF(2)	Module Definition 2. Data line for Serial ID	3
5	MOD_DEF(1)	Module Definition 1. Clock line for Serial ID	3
6	MOD_DEF(0)	Module Definition 0. Grounded within the module	3
7	Rate Select	No connection required	4
8	LOS	Loss of Signal indication. Logic 0 indicates normal operation	5
9	V _{EER}	Receiver Ground (Common with Transmitter Ground)	1
10	V _{EER}	Receiver Ground (Common with Transmitter Ground)	1
11	V _{EER}	Receiver Ground (Common with Transmitter Ground)	1
12	RD-	Receiver Inverted DATA out. AC Coupled	
13	RD+	Receiver Non-inverted DATA out. AC Coupled	
14	V _{EER}	Receiver Ground (Common with Transmitter Ground)	1
15	V _{CCR}	Receiver Power Supply	
16	V _{CCT}	Transmitter Power Supply	
17	V _{EET}	Transmitter Ground (Common with Receiver Ground)	1
18	TD+	Transmitter Non-Inverted DATA in. 100 ohm termination between TD+ and TD-, AC Coupled thereafter	
19	TD-	Transmitter Inverted DATA in. See TD+	
20	V _{EET}	Transmitter Ground (Common with Receiver Ground)	1

Notes:

1. Circuit ground is internally isolated from chassis ground.
2. Laser output disabled on T_{DIS} >2.0V or open, enabled on T_{DIS} <0.8V.
3. Should be pulled up with 4.7k – 10kohms on host board to a voltage between 2.0V and 5.5V. MOD_DEF(0) pulls line low to indicate module is plugged in.
4. Receiver achieves multi-rate operation without active control.
5. LOS is open collector output. Should be pulled up with 4.7k – 10kohms on host board to a voltage between 2.0V and 5.5V. Logic 0 indicates normal operation; logic 1 indicates loss of signal.

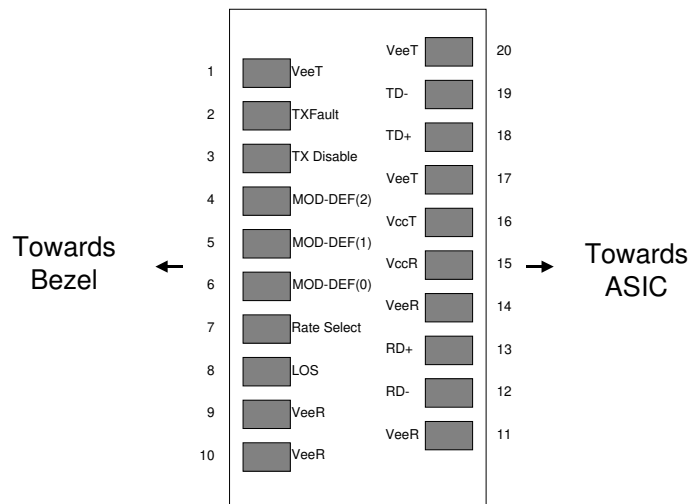

II. Absolute Maximum Ratings

Parameter	Symbol	Min	Typ	Max	Unit
Maximum Supply Voltage	V _{CC}	-0.5		4.7	V
Storage Temperature	T _S	-40		85	°C
Case Operating Temperature	T _{OP}	-5		70	°C

III. Electrical Characteristics (T_{OP} = -5 to 70 °C, V_{CC} = 3.13 to 3.50 Volts)

Parameter	Symbol	Min	Typ	Max	Unit	Ref.
Supply Voltage	V _{CC}	3.13	3.30	3.50	V	
Supply Current	I _{CC}			380	mA	
Inrush Current	I _{surge}			I _{CC} +30	mA	
Maximum Power	P _{max}			1.3	W	
TRANSMITTER						
Input differential impedance	R _{in}		100		Ω	1
Single ended data input swing	V _{in,pp}	250		1200	mV	
Transmit Disable Voltage	V _D	V _{CC} - 1.3		V _{CC}	V	
Transmit Enable Voltage	V _{EN}	V _{EE}		V _{EE} + 0.8	V	2
RECEIVER						
Single ended data output swing	V _{out,pp}	175		1000	mV	3
Data output rise time	t _r			150	ps	4
Data output fall time	t _f			150	ps	4
LOS Fault	V _{LOS fault}	V _{CC} - 0.5		V _{CCHOST}	V	5
LOS Normal	V _{LOS norm}	V _{EE}		V _{EE} +0.5	V	5
Power Supply Rejection	PSR	100			mVpp	6

Notes:

1. Connected directly to TX data input pins. AC coupled thereafter.
2. Or open circuit.
3. Into 100 ohms differential termination.
4. 20 – 80 %
5. Loss of signal (LOS) is LVTTTL. Logic 0 indicates normal operation; logic 1 indicates no signal detected.
6. Receiver sensitivity is compliant with power supply sinusoidal modulation of 20 Hz to 1.5 MHz up to specified value applied through the recommended power supply filtering network.

IV. Low Speed Signals

Parameter	Symbol	Min	Typ	Max	Units	Notes/Conditions
RX_LOS Assert Level		-42	-36		dBm	
RX_LOS Deassert Level			-34	-32	dBm	
RX_LOS Hysteresis		0.5	2		dB	
RX_LOS Assert Delay	t_loss_on			100	μsec	From detection of loss of signal to assertion of RX_LOS
RX_LOS Negate Delay	t_loss_off			100	μsec	From detection of presence of signal to negation of RX_LOS
TX_DISABLE Assert Time	t_off			10	μsec	Rising edge of TX_DISABLE to fall of output signal below 10% of nominal
TX_DISABLE Negate Time	t_on			20	ms	Falling edge of TX_DISABLE to rise of output signal above 90% of nominal. Time indicated is under steady-state temperature conditions.
TX_DISABLE Reset Time	t_reset	10			μsec	TX_DISABLE HIGH before TX_DISABLE set LOW
TX_FAULT Assert		-0.2		+0.2	nm	TX_Fault will assert before the device is outside of specified wavelength range

V. Optical Parameters

Parameter	Symbol	Min	Typ	Max	Units	Notes/Conditions
TRANSMITTER CHARACTERISTICS						
Center Wavelength Spacing			100		GHz	Corresponds to approximately 0.8 nm
Modulated Spectral Width	$\Delta\lambda_{20}$		0.2	0.3	nm	Full width, -20dB from max. See note 3
Transmitter Center Wavelength – End of Life	λ_c	X - 100	X	X + 100	pm	X = specified ITU center wavelength
Transmitter Center Wavelength – Start of Life	λ_c	Y - 50	Y	Y + 50	pm	Y = specified BOL center wavelength
Side Mode Suppression Ratio (SMSR)	SMSR	30			dB	Modulated
Optical Rise/Fall Time	t_r / t_f			160	ps	Unfiltered, 80% -20%
Transmitter Optical Output Power	P_{out}	0		+4	dBm	Average power coupled into single mode fiber
Transmitter Extinction Ratio	OMI	8.2			dB	
Transmitter Eye Opening		10			%	OC-48 eye mask margin
Transmitter Jitter (peak to peak)				75	mUI	Parameter per GR-253 ² section 5.6 for OC-48 B
Tolerable Back Reflection	BR			-14	dB	See note 4
Relative Intensity Noise	RIN			-120	dB/Hz	
Dispersion Power Penalty at 2400ps/nm	DPP			3.0	dB	See Note 5
RECEIVER CHARACTERISTICS						
Optical Input Wavelength	P_{in}	1520		1570	nm	
Receiver Jitter Generation				75	mUI	Parameters per GR-253 ² section 5.6 for OC-48 B
Optical Input Power (BER < 10 ⁻¹²)	P_{in}	-28		-9	dBm	2.5 Gb/s w/ PRBS 2 ²³ -1
Optical Input Power – Receiver Damage Threshold				+6	dBm	
Receiver Reflectance	R_{RX}			-27	dB	
Dispersion Noise Penalty at 2400ps/nm	DNP			3.0	dB	See Note 6

Notes:

- Parameters are specified over temperature and voltage, at end of life unless otherwise noted.
- All parameters are measured on a Finisar SFP Evaluation Card unless otherwise noted.
- For accurate $\Delta\lambda_{20}$ measurements, an OSA with a resolution band width of ≤ 20 pm is recommended.
- Tolerable back reflection is the max back reflection level at which the power penalty will be <1dB.
- Dispersion power penalty is measured in loop back with OSNR set to 28 dB. Data rate and pattern used same as specified for Optical Input Power. Dispersion power penalty is the difference in Rx power at a BER of 10⁻¹² for 0ps/nm and 2400ps/nm.
- Dispersion noise penalty is measured in loop back with Rx power set between -9dBm and -22dBm. Data rate and pattern used same as specified for Optical Input Power. Dispersion noise penalty is the difference in OSNR at a BER of 10⁻¹² for 0ps/nm and 2400ps/nm.

VI. Wavelength Stabilization

The laser transmitter will not be turned on until its temperature is adjusted to ensure operation within the specified channel ($X \pm 300\text{pm}$). This temperature stabilization time is dependent on the ambient temperature conditions, but will typically occur within 5 seconds of powering the device. The module will transmit within the specified wavelength tolerance ($X \pm 100\text{pm}$) within 10 ms of transmitter operation.

VII. General Specifications

Parameter	Symbol	Min	Typ	Max	Units	Notes/Conditions
Data Rate	BR	0.155		2.7	Gb/sec	SONET OC-3/12/48 compatible
Total Link Budget		28	30		dB	@ 2.5 Gb/s, BER $<10^{-12}$ w/ PRBS $2^{23}-1$. See Note 1

Note 1: Total link budget is defined as $P_{\text{out}} - P_{\text{in}}$ - typical connector losses.

VIII. Environmental Specifications

Parameter	Symbol	Min	Typ	Max	Units	Notes/Conditions
Operating Temp	T_{op}	-5		70	$^{\circ}\text{C}$	Case temperature measured on top-side of device
Storage Temp	T_{sto}	-40		85	$^{\circ}\text{C}$	Ambient temperature
Eye Safety						CDRH and IEC-825 Class 1 Laser Product. See Note 1

Note 1: Complies with FDA performance standards for laser products except for deviations pursuant to Laser Notice No. 50, dated June 24, 2007.

IX. Serial Communication Protocol

Finisar SFPs support diagnostic features as described in Finisar Applications Note AN-2030⁴ and SFF-8472⁷, “Digital Diagnostic Monitoring Interface for Optical Transceivers”. A controller IC that monitors system parameters such as laser current, module temperature, transmitter power, and received power is accessible at address A2h. In addition, Finisar’s DWDM SFPs provide extended set of ID information and diagnostic features as described in the DWDM SFP MSA⁶.

2-wire serial communication clock speed, digital diagnostic accuracy and digital diagnostic range can be found in the table below. Values in the table represent the worst-case values over temperature, voltage, and life.

Parameter	Symbol	Min	Max	Units	Notes/Conditions
2-wire serial communication clock speed		0	100,000	Hz	Bus can be driven blind
Accuracy					
Transceiver Case Temperature	DD _{Temperature}	-10	+10	°C	Measured on the top-side of the module case
Transceiver Supply Voltage	DD _{Voltage}	-3	+3	%	
Tx Bias Current	DD _{Bias}	-10	+10	%	
Tx Output Power	DD _{TxPower}	-2	+2	dB	
Received Average Power	DD _{RxPower}	-2	+2	dB	
Range					
Transceiver Case Temperature	DD _{Temperature}	-40	85	°C	
Transceiver Supply Voltage	DD _{Voltage}	3.0	4.0	V	
Tx Bias Current	DD _{Bias}	0	90	mA	
Tx Output Power	DD _{TxPower}	-5	+10	dBm	
Received Average Power	DD _{RxPower}	-30	-7	dBm	

X. Mechanical Specifications

Finisar's Multi-rate DWDM Small Form Factor Pluggable (SFP) transceivers are compatible with the dimensions defined by the DWDM SFP Multi-Sourcing Agreement (MSA)⁶.

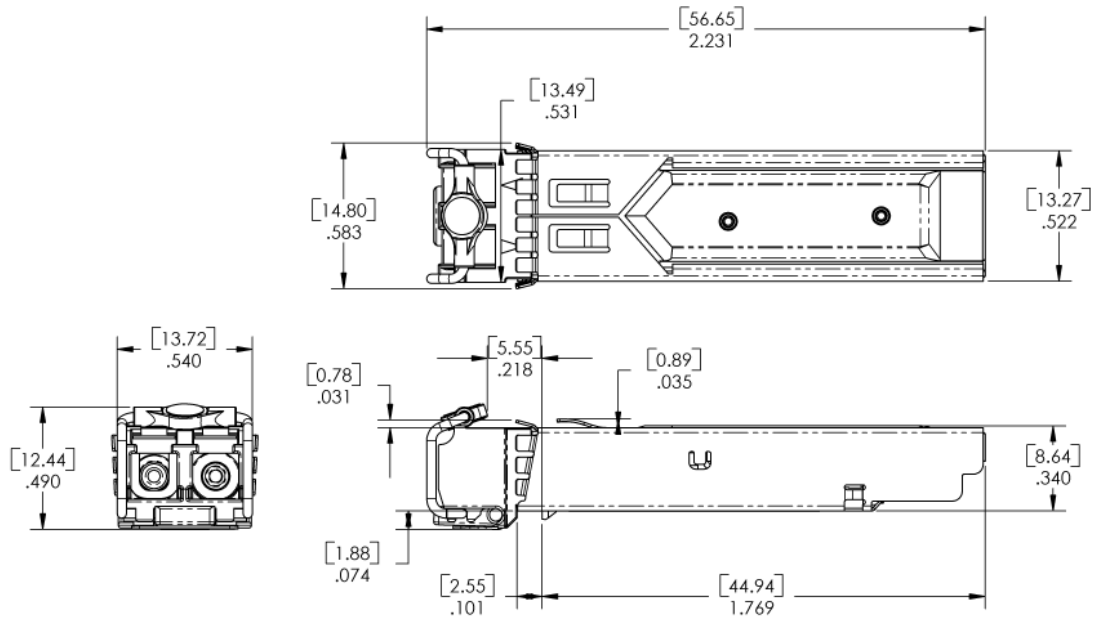

Figure 1. DWDM SFP Outline Drawing (units in inches [mm])

XI. References

1. Small Form Factor Pluggable (SFP) Transceiver Multi-Source Agreement (MSA), September 2000. Documentation is currently available from Finisar upon request.
2. “SONET Transport Systems: Common Generic Criteria”, Telcordia Technologies, GR-253-CORE, Issue 3, September 2000.
3. Directive 2011/65/EU of the European Council Parliament and of the Council, “on the restriction of the use of certain hazardous substances in electrical and electronic equipment”
4. “Application Note AN-2038: Finisar Implementation Of RoHS Compliant Transceivers”
5. “Application Note AN-2030: Digital Diagnostic Monitoring Interface for Optical Transceivers”, Finisar Corporation, April 2002.
6. Specifications for DWDM SFP Transceiver Draft 1.0.October 21 2005. Documentation is available from Finisar upon request.
7. “Digital Diagnostic Monitoring Interface For Optical Transceivers Rev 9.3”. SFF Document No. SFF-8472.

For More Information

Finisar Corporation
1389 Moffett Park Drive
Sunnyvale, CA 94089-1133
Tel. 1-408-548-1000
Fax 1-408-541-6138
sales@finisar.com
www.finisar.com