

NOTES:

1. ELECTRICAL:

- VOLTAGE RATING PER IEC 60664: 300V
- VOLTAGE RATING PER UL: 300V
- CURRENT: 8A

2. TEMP RATING: -25° TO +60°C

3. PROTECTION: IP67 (WHEN MATED)

4. COUPLING THREAD" 7/8-16

5. AGENCY:

- UL RECOGNIZED, FILE: E152210
- CSA CERTIFICATION FILE: LR6837

6 ALL DIMS ARE FOR REFERENCE UNLES NOTED OTHERWISE

7. PART NUMBERS WITH "H" HAVE TWO ID MARKERS ONE ON EACH END

WIRING DIAGRAM

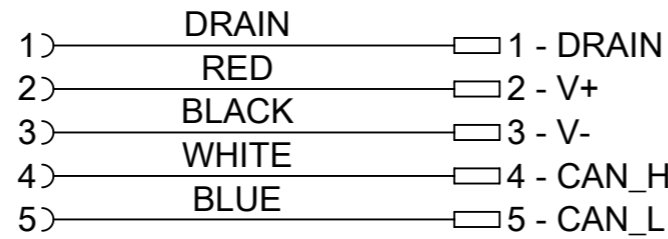

PART No. MATRIX

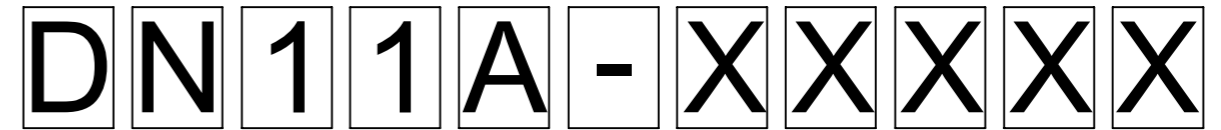

Units:
M = Meter
T = over
100 Meter

Length
Examples:
005 = 0.5 m
010 = 1 m
050 = 5 m
100 = 10 m
150 = 15 m

OPTIONAL:
H = ID CARRIER

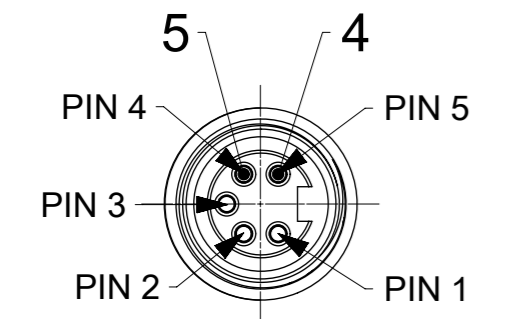

VIEW FROM THE FRONT SIDE

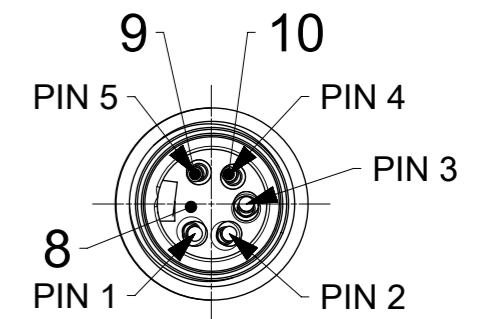
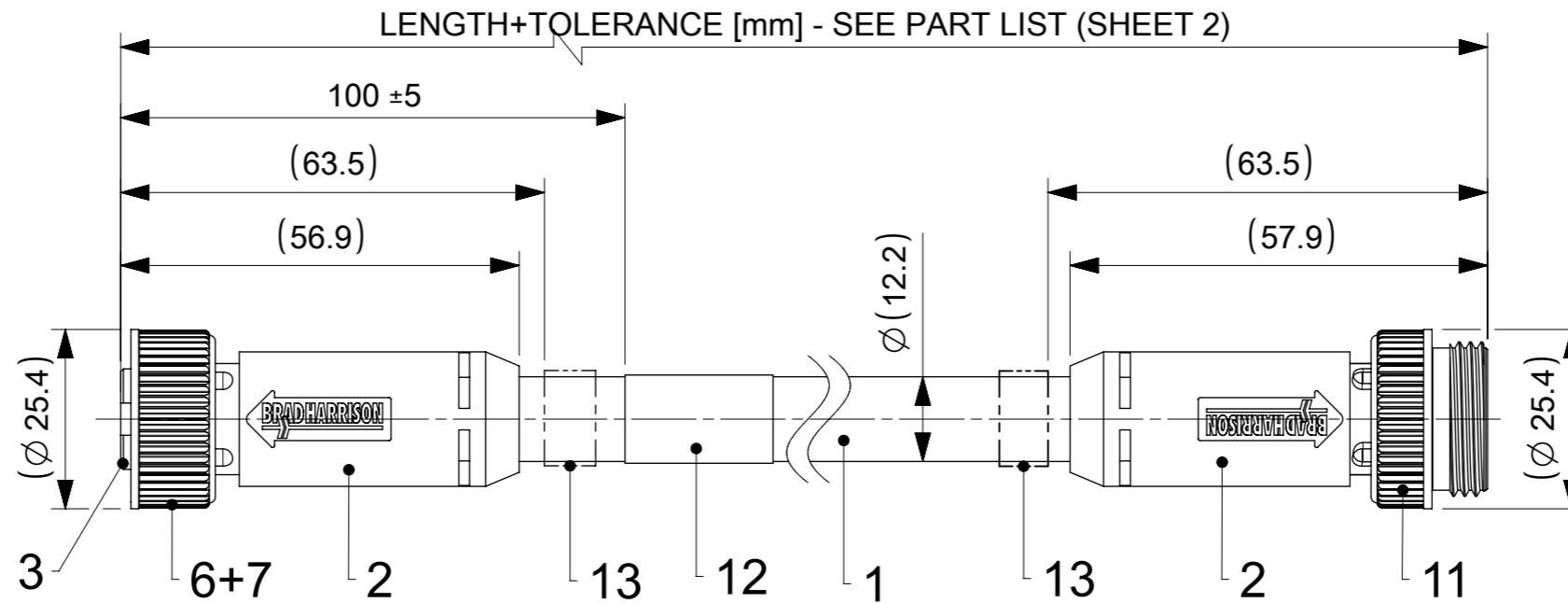

VIEW FROM THE FRONT SIDE

BILL OF MATERIALS

ITEM	QTY	DESCRIPTION	MATERIAL	FINISH/COLOR
13	2	ID CARRIER	PVC	-
12	1	LABEL WRAP	VINYL	YELLOW
11	1	COUPLING NUT A-SIZE EXT.	ZINC	BLACK
10	2	PIN CONTACT 16 AWG	COPPER	GOLD OVER Ni-PLATED
9	3	PIN CONTACT 18 AWG	COPPER	GOLD OVER Ni-PLATED
8	1	HOUSING A-SIZE 5P MALE	ARNITEL	BLACK
7	1	FRICTION RING A-SIZE	NYLON	GRAY
6	1	MC COUPLING NUT A-SIZE	ZINC	BLACK
5	2	MC SOCKET SLEEVE ASSY 16 AWG	COPPER	GOLD OVER Ni-PLATED
4	3	MC SOCKET SLEEVE ASSY 18 AWG	COPPER	GOLD OVER Ni-PLATED
3	1	HOUSING A-SIZE 5P FEMALE	ARNITEL	BLACK
2	-	MOULDING MATERIAL	ARNITEL	BLACK
1	-	TRUNK CABLE 19X30 AWG OD=12	PVC	GRAY

DOCUMENT STATUS	P1	RELEASE DATE	2022/02/15	09:19:21
-----------------	----	--------------	------------	----------

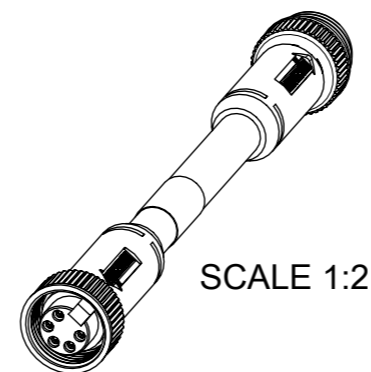

SCALE 1:2

FUNCTIONAL SYMBOLS	THIS DRAWING CONTAINS INFORMATION THAT IS PROPRIETARY TO MOLEX ELECTRONIC TECHNOLOGIES, LLC AND SHOULD NOT BE USED WITHOUT WRITTEN PERMISSION		CURRENT REV DESC: PIN'S ADDED, NOTES UPDATED	
	△/A = 0	mm	SCALE 1:1	
DIVISIONAL SYMBOLS	GENERAL TOLERANCES (UNLESS SPECIFIED)			
	△/E = 0	ANGULAR TOL ± 1.0°		
	△/F = 0	4 PLACES ±	EC NO: 695738	
		3 PLACES ±	DRWN: RSCHIEBER	2022/02/14
		2 PLACES ± 0.05	CHK'D: RSILLER	2022/02/15
	1 PLACE ± 0.3	APPR: RSILLER	2022/02/15	
	0 PLACES ± 0.5	INITIAL REVISION:		
DRAFT WHERE APPLICABLE MUST REMAIN WITHIN DIMENSIONS		DRWN: MKOWALCZYK01	2018/09/07	
THIRD ANGLE PROJECTION		APPR: MMATLA	2018/09/11	
DRAWING A3-SIZE		SERIES 130025	MATERIAL NUMBER SEE SHEET 2	CUSTOMER GENERAL MARKET
		DOCUMENT NUMBER 1300250051		DOC TYPE PSD
				DOC PART 000
				REVISION B1
				SHEET NUMBER 1 OF 2

