

SNG-S SERIES

005993
Issue 5

Speed Sensors

DESCRIPTION

Honeywell's SNG-S Series Speed Sensors use a magnetically biased Hall-effect integrated circuit (IC) to accurately sense movement of ferrous metal targets. The specially designed IC and a permanent magnet are sealed in rugged, probe-type packages. The IC detects the alteration of the magnet's flux density when it is approached by ferrous metal. A sensor positioned at the circumference of a revolving gear wheel detects the teeth and spaces, and supplies a digital pulse output with frequency proportional to gear wheel speed. Optimum performance is dependent upon a combination of variables such as target material, geometry and speed, sensor/target gap, and environmental temperature.

VALUE TO CUSTOMERS

- Higher reliability: IP69K rating, EMC radiated immunity protection, O-ring seal and wide operating temperature range:
 - Improves equipment uptime
 - Minimizes service costs
 - Provides resistance to high electrical noise
 - Provides resistance to moisture intrusion
 - Wide operating temperature range
- Cost-competitive: Designed and manufactured using a platform-based approach that enables better cost competitiveness and mechanical and electrical configurability for customers.
- Flexible: Wide operating temperature range, robust electrical noise immunity and enhanced environmental sealing capability allow flexibility of use in the application.
- Expedites installation: O-ring seal for use in pressure applications and a fixed mounting flange allows for a simpler installation process, using one fastener.

FEATURES

- Wide operating temperature range: -40°C to 140°C [-40°F to 284°F]
- Insensitive to orientation (angular rotation) during assembly
- Environmental sealing: Moisture ingress protection rated to IP69K
- Robust electrical noise immunity: Electrical noise radiated immunity (EMC) rated to 100 V/m
- Zero speed detection, high frequency switching capability: 0 kHz to 15 kHz
- O-ring seal: Enables environmental sealing to mounting surface
- Supply voltage range: varies from 4.5 V to 24 V or 4.5 V to 8 V to 24 V
- CE, UKCA certified

POTENTIAL TRANSPORTATION APPLICATIONS

- Transmission speed sensing in heavy duty trucks, buses, agriculture and construction machines
- Wheel speed detection in material handling, agriculture, and construction machines
- Motor speed sensing in vehicle powertrain and hybrid engines in heavy duty trucks, buses, agriculture and construction machines

Not recommended for Aerospace or Defense applications.



PORTFOLIO



The SNG-S Series is part of a portfolio of electronic speed and position sensors that use a variety of technologies to detect speed, direction, or position of a moving ferrous metal or magnetic target.

Honeywell

SPEED SENSORS SNGS-S SERIES

TABLE 1. ELECTRICAL SPECIFICATIONS

CHARACTERISTIC	CONDITION/COMMENT	PARAMETER			
		SNG-SPRF-002	SNG-SPRD-002 SNG-SPSC-001 SNG-SPRC-001	SNG-SPRD-003 SNG-SPRC-002	SNG-SPRD-004 SNG-SPRC-003
Supply Voltage	Regulated supply and 12 V battery ISO 16750-2	4.5 V to 24 V —	— 8 V to 16 V	— 4.8 V to 16 V	— 4.8 V to 24 V
Supply Current	—	20 mA max.	15 mA		
Reverse Voltage Protection	— ISO 16750-2	-24 V —	— -14 Vdc		
Over Voltage Protection	— ISO 16750-2	26.5 V —	— 26 V		
Short Circuit Protection	— ISO 16750-2	16 V —	— 16 V		
Load Dump	ISO 16750-2:2012 11 01 (US* = 40 V, UA 13.5 ±0.5 V)	5b —	— —		
Insulation Resistance	ISO 16750-2:2012	>10 MΩhm at 500 Vdc —	— —		

TABLE 2. ENVIRONMENTAL SPECIFICATIONS

CHARACTERISTIC	CONDITION/COMMENT	PARAMETER	
		SNG-SPRF-002	ALL OTHER CATALOG LISTINGS
Radiated Immunity	ISO 11452-2: 2004 ISO 11452-2: 2004 IEC 61000-4-3: 2008 ISO 11452-2, 400 MHz to 2.5 GHz	10 kHz to MHz, 60 m/V 200 MHz to 2.7 GHz, 100 V/m 800 kHz MHz to 1000 MHz, 3 m/V —	— — — 100 V/m
Bulk Current Injection	ISO 11452-4, 1 MHz to 400 MHz	100 mA	
ESD	SAE J1113/13 ISO 10605	±4 kV contact, ±8 kV air —	— ±8 kV contact, ±15 kV air
Conductive Transients	ISO 7637-2, for 12 V system ISO 7637-2, for 12 V system	TEST PULSE 1, 2a, 2b, 3a, 3b —	— PULSE 1, 2a, 3a, 3b, 5a
Conducted Emissions	CISPR 25. 150 kHz to 108 MHz	—	Class 3
Radiated Emissions	CISPR 25. 150 kHz to 12.5 GHz	—	Class 3
Thermal Cycle	-40°C to 140°C	—	100 cycles
Humidity	— 95 %RH at 55°C	10 %RH to 90 %RH at -40°C to 85°C, 150 cycles, 600 hr total —	— 144 hr, EN/IEC 60068-2-30
Saline Dunk	0°C to 110°C	—	10 cycles, ISO 16750-4
Salt Fog	5% salt solution by mass at 35°C and 93% RH for 400 hr, tested to 2000 hr with no ingress in the sensor packaging area 5% salt solution by mass at 35°C	5% salt solution by mass at 35°C and 93% RH for 2000 hr —	— 96 hours
Combined Temperature and Vibration Test	sinusoidal: 25 hr/axis, 3 perpendicular axes 30 g at 60 Hz to 1000 Hz and 15 g at 1000 Hz to 2000 Hz random: 25 hr/axis, 3 perpendicular axes 30 g at 25 rms Hz to 2000 Hz, -40°C to 125°C	sinusoidal: 25 hr/axis, 3 perpendicular axes, 15 g at 5 Hz to 2000 Hz random: 25 hr/axis, 3 perpendicular axes at 25 grms at 10 Hz to 2000 Hz	— —
Vibration	3 perpendicular axes, 48 hr per axis	—	29.8 GRMS, 24 Hz to 2000 Hz, MIL-STD-202-214
Degree of Protection	IEC 50629 IEC 60529	IPX6, IPX9K, IPX7 —	— IP69K, IP67
Resistance to Fluids	—	—	general under-the-hood automotive fluids
Operating Temperature	—	-40°C to 150°C	-40°C to 140°C
Storage Temperature	—	-55°C to 70°C	-40°C to 140°C

SPEED SENSORS SNGS-S SERIES

TABLE 3. MECHANICAL SPECIFICATIONS

CHARACTERISTIC	PARAMETER			
	SNG-SPRF-002	SNG-SPRD-002 SNG-SPSC-001 SNG-SPRC-001	SNG-SPRD-003 SNG-SPRC-002	SNG-SPRD-004 SNG-SPRC-003
Carrier Material	PBT thermoplastic	PBT		
Bushing Material	SS304	SSTL		
O-ring Material	70 durometer fluorocarbon, PTFE coating 17,0 mm ID x 2,0 mm CS	fluorocarbon, brown 17,0 mm ID x 2,0 mm CS		
Housing Material	PBT	PBT		
Connector: Integral Mating	Bosch 928000453 Bosch 1928403966	Amp Superseal 1.5 282087		
Mounting Torque	8 ±0,5 N m with M6 screw	20 ±3 N m with M8 screw		
O-ring Lubrication	mineral oil-based grease			
Agency Certifications	CE, UKCA			

FIGURE 1. GENERAL NOMENCLATURE

For example, **SNG-SPRC-001** defines an SNG-S Series speed sensor, plastic housing, integral connector, right angle exit, 46 mm housing length.

SNG-S	P	S	C	-	001
Series	Housing Material ¹	Connection Type ²	Housing Length		For Internal Use Only
speed sensor	P Plastic	R Integral connector, right angle exit S Integral connector, straight exit	C 46 mm D 67 mm F 24 mm		

¹ Contact Honeywell for other Housing Material options.

² Other cable lengths available upon request.

TABLE 4. ORDER GUIDE

CATALOG LISTING	DESCRIPTION
SNG-SPRF-002	SNG-S Series, speed sensor, plastic housing, integral Bosch connector, 24 mm housing length, right angle exit, 4.5 V to 24 V supply voltage
SNG-SPSC-001	SNG-S Series, speed sensor, plastic housing, integral Amp Superseal 1.5 connector, 46 mm housing length, straight exit, 8 V to 16 V supply voltage
SNG-SPRC-001	SNG-S Series, speed sensor, plastic housing, integral Amp Superseal 1.5 connector, 46 mm housing length, right angle exit, 8 V to 16 V supply voltage
SNG-SPRC-002	SNG-S Series, speed sensor, plastic housing, integral Amp Superseal 1.5 connector, 46 mm housing length, right angle exit, 4.8 V to 16 V supply voltage
SNG-SPRC-003	SNG-S Series, speed sensor, plastic housing, integral Amp Superseal 1.5 connector, 46 mm housing length, right angle exit, 4.8 V to 24 V supply voltage
SNG-SPRD-002	SNG-S Series, speed sensor, plastic housing, integral Amp Superseal 1.5 connector, 67 mm housing length, right angle exit, 8 V to 16 V supply voltage
SNG-SPRD-003	SNG-S Series, speed sensor, plastic housing, integral Amp Superseal 1.5 connector, 67 mm housing length, right angle exit, 4.8 V to 16 V supply voltage
SNG-SPRD-004	SNG-S Series, speed sensor, plastic housing, integral Amp Superseal 1.5 connector, 67 mm housing length, right angle exit, 4.8 V to 24 V supply voltage

SPEED SENSORS SNGS-S SERIES

FIGURE 2. SCHEMATIC DIAGRAMS AND OUTPUT SPECIFICATIONS

SNG-SPRF-002

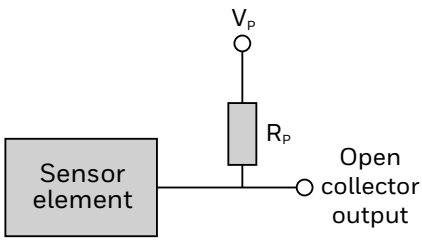

CHARACTERISTIC	CONDITION/ COMMENT	PARAMETER
Signal Type	Open collector	Square wave
Power on	—	Default high and start from initial edge
Signal Polarity	Not dependent on target rotation	Output low on teeth
Output Signal: High Low	— —	$\geq V_p - 0.5 V$ $\leq 0.6 V$
Load Current	Output leakage current $-10 \mu A$	10 mA max.
Frequency	—	0 kHz to 10 kHz

SNG-SPRD-003
SNG-SPRC-002

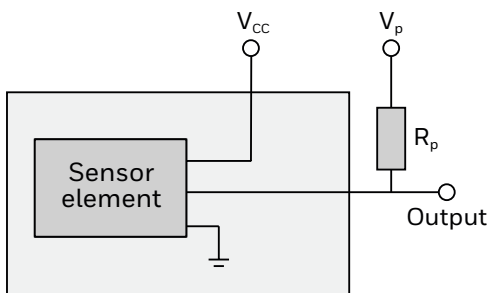

CHARACTERISTIC	CONDITION/ COMMENT	PARAMETER
Signal Type	Open collector	Square wave
Output Signal: High Low	Dependent on the controller interface	$\geq V_{CC} - 0.5 V$ $\leq 0.5 V$
Load Current	—	20 mA
Frequency	—	0 kHz to 10 kHz

SNG-SPRD-002
SNG-SPSC-001
SNG-SPRC-001

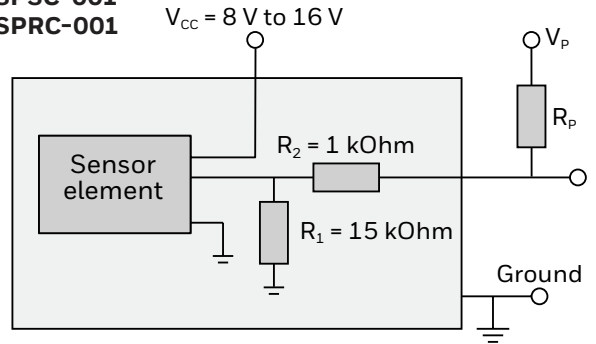

CHARACTERISTIC	CONDITION/ COMMENT	PARAMETER
Signal Type	Open collector	Square wave
Output Signal: High Low	Dependent on target geometry and sensor-to-target orientation	$(V_p \times (16.5)/(16.5 + R_p \text{ in kOhm})) 0.3 V \text{ to } 2.2 V$ $\leq ((V_p - 0.4) \times 1 k) / (1 k + R_p \text{ in Ohm}) + 0.4$
Load Current	—	15 mA
Frequency	—	0 kHz to 10 kHz

SNG-SPRD-004
SNG-SPRC-003

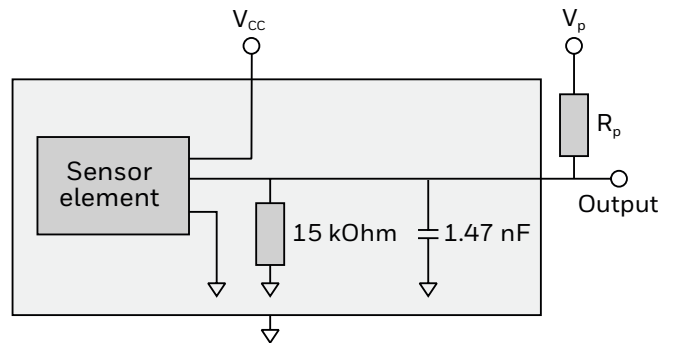

CHARACTERISTIC	CONDITION/ COMMENT	PARAMETER
Signal Type	Open collector	Square wave
Output Signal: High Low	Dependent on the controller interface	$(V_p \times (16.5)/(16.5 + R_p \text{ in kOhm})) 0.5 V$ $< 0.5 V$
Load Current	—	20 mA
Frequency	—	0 kHz to 10 kHz

SPEED SENSORS SNGS-S SERIES

FIGURE 3. MOUNTING DIMENSIONS (FOR REFERENCE ONLY: MM/[IN.])

24 mm, right angle: SNG-SPRF-002

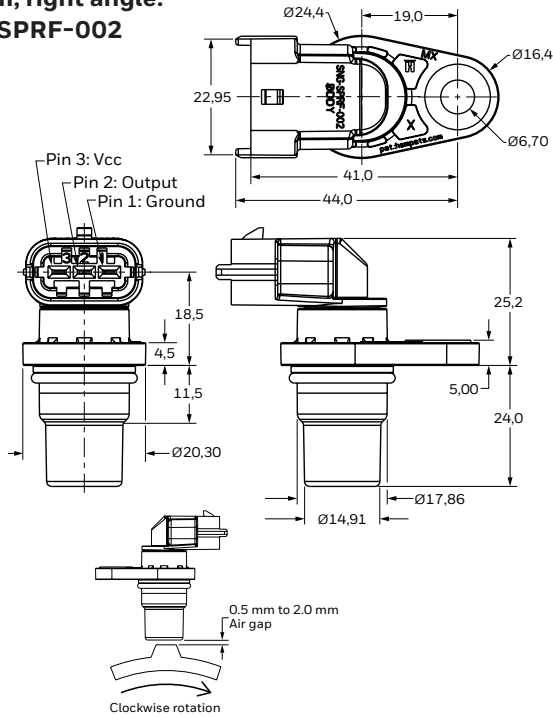

46 mm, straight: SNG-SPSC-001

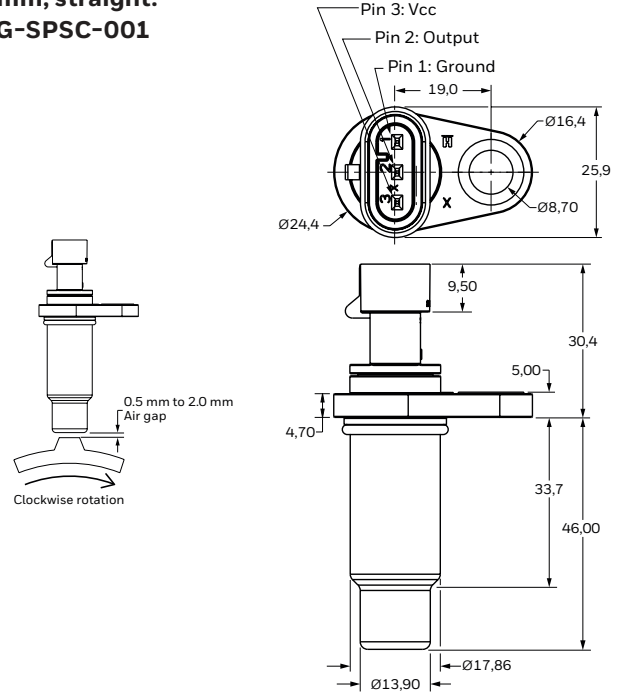

46 mm, right angle: SNG-SPRC-001 SNG-SPRC-002 SNG-SPRC-003

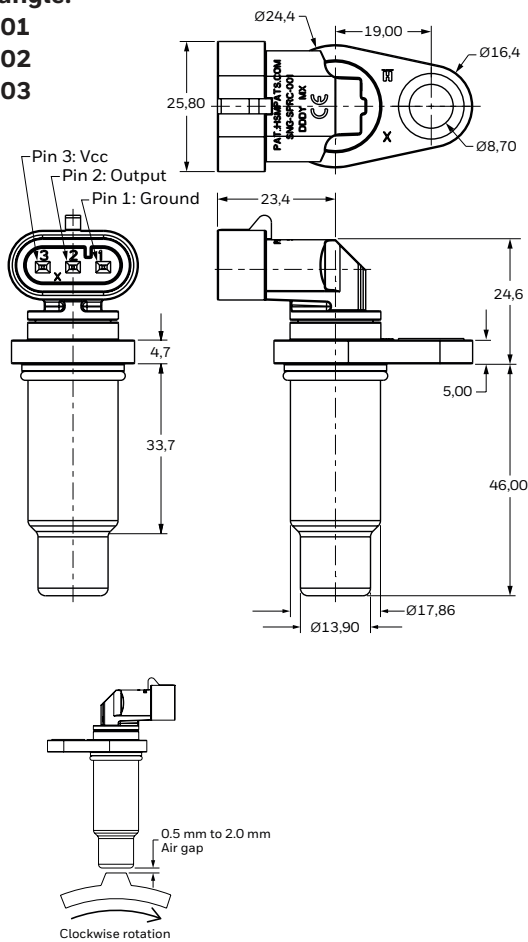

67 mm, right angle: SNG-SPRD-002 SNG-SPRD-003 SNG-SPRD-004

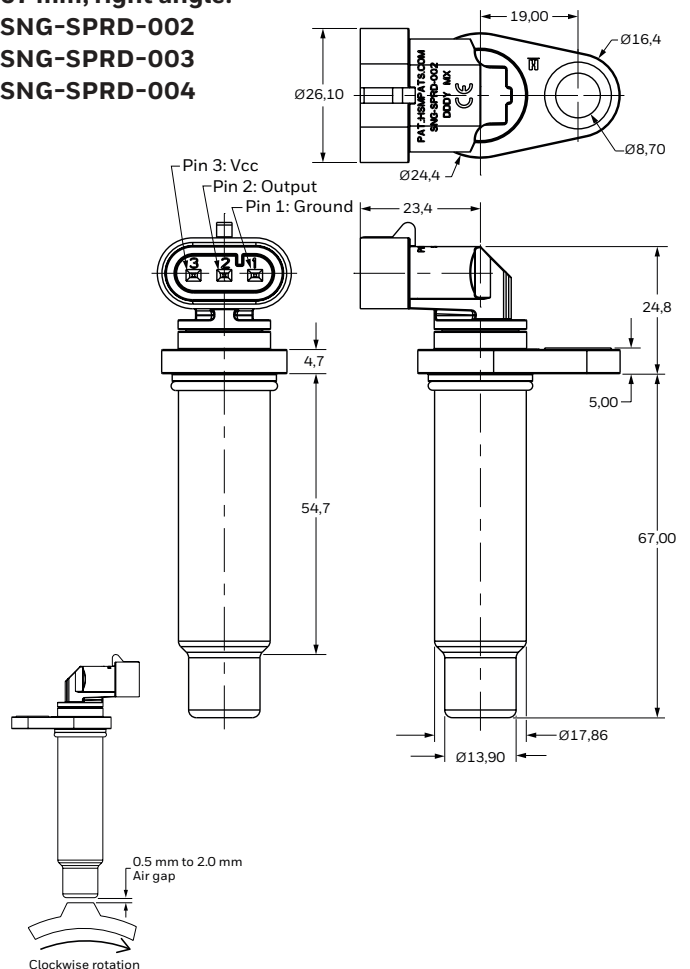
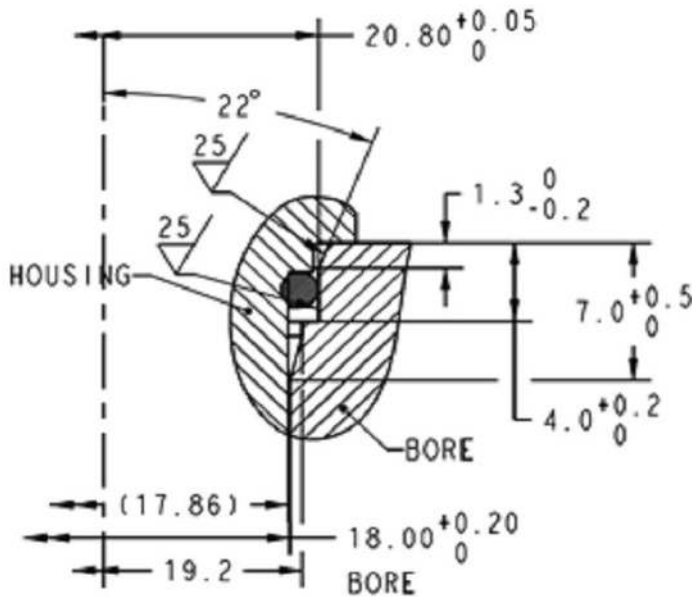

FIGURE 4. CUSTOMER INTERFACE BORE



WARRANTY/REMEDY

Honeywell warrants goods of its manufacture as being free of defective materials and faulty workmanship during the applicable warranty period. Honeywell's standard product warranty applies unless agreed to otherwise by Honeywell in writing; please refer to your order acknowledgment or consult your local sales office for specific warranty details. If warranted goods are returned to Honeywell during the period of coverage, Honeywell will repair or replace, at its option, without charge those items that Honeywell, in its sole discretion, finds defective.

The foregoing is buyer's sole remedy and is in lieu of all other warranties, expressed or implied, including those of merchantability and fitness for a particular purpose. In no event shall Honeywell be liable for consequential, special, or indirect damages.

FOR MORE INFORMATION

Honeywell Sensing and Safety Technologies services its customers through a worldwide network of sales offices and distributors. For application assistance, current specifications, pricing or the nearest Authorized Distributor, visit [our website](#) or call:

USA/Canada	+1 302 613 4491
Latin America	+1 305 805 8188
Europe	+44 1344 238258
Japan	+81 (0) 3-6730-7152
Singapore	+65 6355 2828
Greater China	+86 4006396841

Honeywell Sensing and Safety Technologies

830 East Arapaho Road
Richardson, TX 75081
sps.honeywell.com/ast

⚠ WARNING PERSONAL INJURY

DO NOT USE these products as safety or emergency stop devices or in any other application where failure of the product could result in personal injury.

Failure to comply with these instructions could result in death or serious injury.

⚠ WARNING MISUSE OF DOCUMENTATION

- The information presented in this product sheet is for reference only. Do not use this document as a product installation guide.
- Complete installation, operation, and maintenance information is provided in the instructions supplied with each product.

Failure to comply with these instructions could result in death or serious injury.

While Honeywell may provide application assistance personally, through our literature and the Honeywell web site, it is buyer's sole responsibility to determine the suitability of the product in the application.

Specifications may change without notice. The information we supply is believed to be accurate and reliable as of this writing. However, Honeywell assumes no responsibility for its use.