

PRODUCT NUMBER

51915-473__
NOTE 3

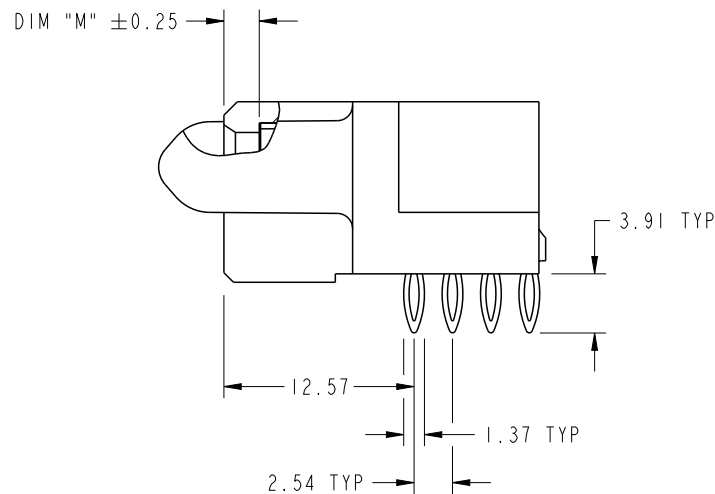

BROKEN-OUT SECTION A-A
SCALE 2:1

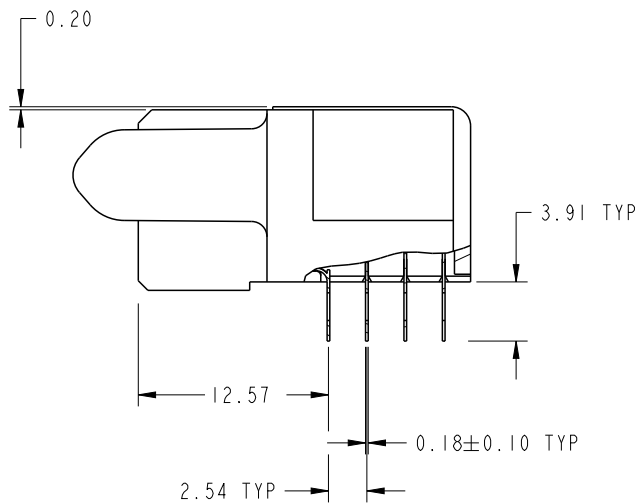
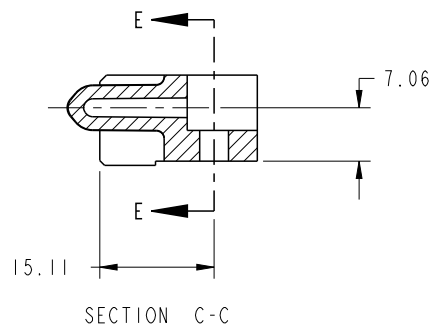

BROKEN-OUT SECTION B-B
SCALE 2:1

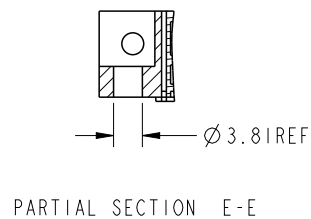

dr	Ruan MT	2014/11/24	projection 	MM ←→	size	A4	scale	1:1	
eng	Ruan MT	2014/12/26			ecn no	-			
chr	-	-			rel level	Released			
appr	Pei-Ming Zheng	2014/12/26	product family	PwrBlade					
		title	12P + 120S R/A STB RECEPTACLE		dwg no	51915-473		rev	A
www.fci.com		cat. no.	Product - Customer Drw			sheet 2 of 4			

PRODUCT NUMBER

51915-473_
NOTE 3

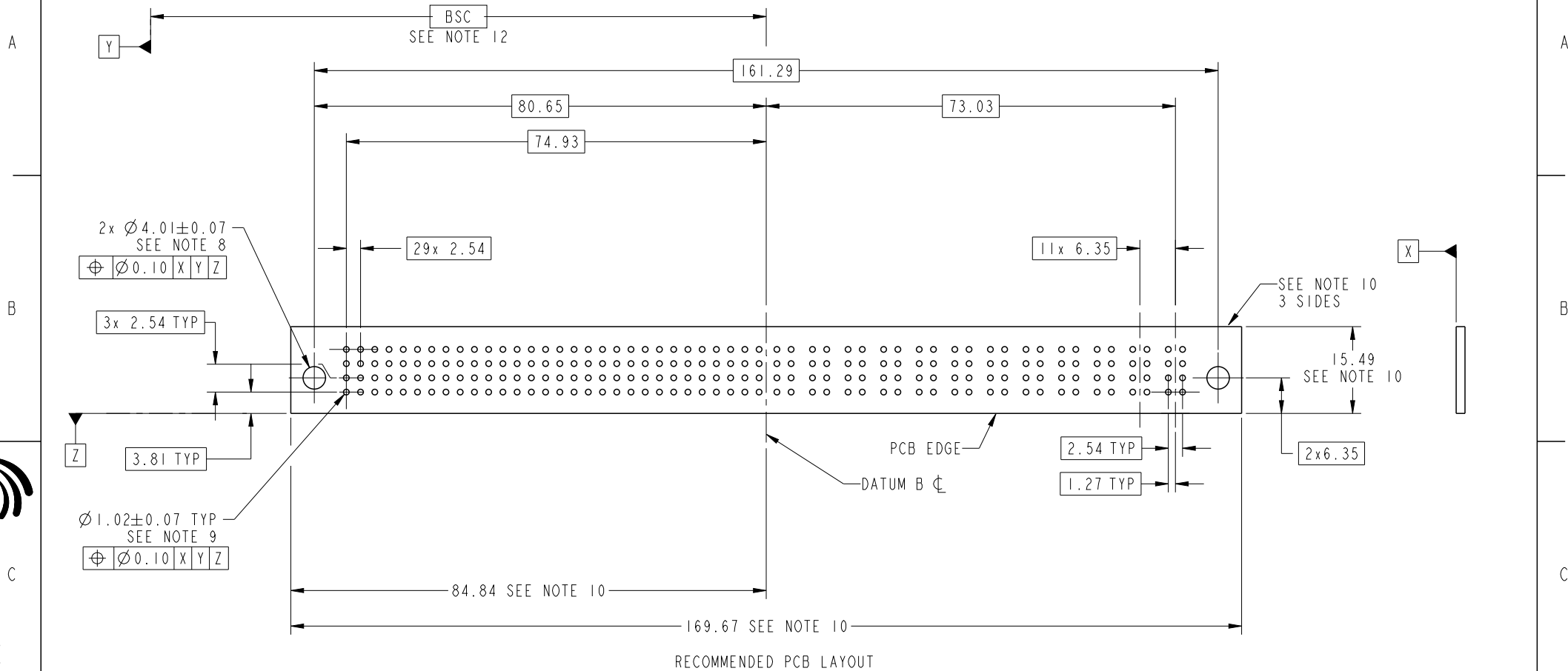

RECOMMENDED PCB LAYOUT

dr	Ruan MT	2014/11/24	projection 	MM ←→	size	A4	scale	1:1
eng	Ruan MT	2014/12/26			ecn no	-		
chr	-	-			rel level	Released		
appr	Pei-Ming Zheng	2014/12/26	product family	PwrBlade				
	title	12P + 120S R/A STB RECEPTACLE		dwg no	51915-473		rev	A
www.fci.com	cat. no.	Product - Customer Drw			sheet 3 of 4			

PRODUCT NUMBER



51915-473__
NOTE 3

NOTES:

1. DIMENSIONS AND TOLERANCES ARE IN ACCORDANCE WITH ASME Y14.5M, 1994 UNLESS OTHERWISE SPECIFIED.

CONNECTOR NOTES:

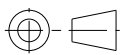
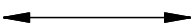
- 2. HOUSING MATERIAL: UL 94 V-0 GLASS FILLED HIGH-TEMP THERMOPLASTIC
POWER CONTACT MATERIAL: COPPER ALLOY
SIGNAL PIN MATERIAL: COPPER ALLOY
 - 3. SEE ITEM 7 & 8 IN PRINT 10064183 FOR PLATING SPEC OF 51915-473 AND 51915-473LF RESPECTIVELY.
 - 4. MANUFACTURER'S NAME, DATE CODE AND OPTIONAL P/N TO APPEAR ON THIS SURFACE. THE MARK CAN BE OMITTED IF THERE IS NOT ENOUGH SPACE ON THIS SURFACE.
 - 5. PRODUCT SPECIFICATION GS-12-149.
APPLICATION SPECIFICATION BUS-20-067.
 - 6. PACKAGED IN TRAYS.
- PCB NOTES:
- 7. ALL HOLE DIAMETERS ARE FINISHED HOLE SIZE.
 - 8. MOUNTING HOLES, WHERE APPLICABLE, ARE UNPLATED.
 - 9. $\varnothing 1.151 \pm 0.025$ DRILLED HOLES PLATED WITH
0.008 MIN SnPb OR Sn OVER 0.03
TO 0.08 Cu PLATING TO ACHIEVE
 $\varnothing 1.02 \pm .07$ HOLE.
 - 10. CONNECTOR KEEP-OUT ZONE.
 - 11. THE VOID CORING IN BETWEEN POWER MODULES, SIGNAL MODULES AND END MODULES ARE OPTIONAL AND THE SHAPE MAY BE DIFFERENT FOR OPTIMIZE THE MOLDING PROCESS. THE VOID CORING WILL NOT EFFECT TO PRODUCT FUNCTION.
 - 12. DATUM AND BASIC DIMENIONS ARE ESTABLISHED BY CUSTOMER.

dr	Ruan MT	2014/11/24	projection 	MM 	size	A4	scale	1:1
eng	Ruan MT	2014/12/26			ecn no	-		
chr	-	-			product family	PwrBlade	rel level	Released
appr	Pei-Ming Zheng	2014/12/26			title 12P + 120S R/A STB RECEPTACLE	dwg no 51915-473	rev A	
www.fci.com		cat. no.	Product - Customer Drw			sheet 4 of 4		



Copyright FCI.