

N-Channel Power MOSFET

450V, 0.5A, 4.25Ω

FEATURES

- Low gate charge @typical 6.5nC
- Low Crss @ typical 6.5pF
- Avalanche energy specified
- Improved dV/dt capability
- Pb-free plating
- Compliant to RoHS Directive 2011/65/EU and in accordance to WEE 2002/96/EC
- Halogen-free according to IEC 61249-2-21 definition

APPLICATION

- Power Supply
- Lighting

KEY PERFORMANCE PARAMETERS		
PARAMETER	VALUE	UNIT
V_{DS}	450	V
$R_{DS(on)}$ (max)	4.25	Ω
Q_g	6.5	nC

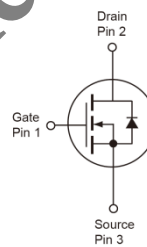

Notes: MSL 3 (Moisture Sensitivity Level) per JEDEC J-STD-020

ABSOLUTE MAXIMUM RATINGS (T _A = 25°C unless otherwise noted)				
PARAMETER		SYMBOL	Limit	UNIT
Drain-Source Voltage		V_{DS}	450	V
Gate-Source Voltage		V_{GS}	±30	V
Continuous Drain Current ^(Note 1)	T _C = 25°C	I_D	0.5	A
Pulsed Drain Current ^(Note 2)		I_{DM}	4	A
Total Power Dissipation @ T _C = 25°C	TO-92	P_{DTOT}	2	W
	SOT-223		15	
Single Pulsed Avalanche Energy ^(Note 3)		E_{AS}	108	mJ
Single Pulsed Avalanche Current ^(Note 3)		I_{AS}	1.6	A
Repetitive Avalanche Energy ^(Note 3)		E_{AR}	0.25	mJ
Repetitive Avalanche Current ^(Note 3)		I_{AR}	0.5	A
Operating Junction and Storage Temperature Range		T _J , T _{STG}	- 55 to +150	°C

THERMAL PERFORMANCE				
PARAMETER		SYMBOL	Limit	UNIT
Junction to Lead Thermal Resistance	TO-92	$R_{\theta JL}$	50	°C/W
Junction to Case Thermal Resistance	SOT-223	$R_{\theta JC}$	8.5	
Junction to Ambient Thermal Resistance	TO-92	$R_{\theta JA}$	140	
	SOT-223		60	

Notes: $R_{\theta JA}$ is the sum of the junction-to-case and case-to-ambient thermal resistances. The case thermal reference is defined at the solder mounting surface of the drain pins. $R_{\theta JA}$ is guaranteed by design while $R_{\theta CA}$ is determined by the user's board design. $R_{\theta JA}$ shown below for single device operation on FR-4 PCB with minimum recommended footprint in still air.

Not Recommended

ELECTRICAL SPECIFICATIONS ($T_A = 25^\circ\text{C}$ unless otherwise noted)						
PARAMETER	CONDITIONS	SYMBOL	MIN	TYP	MAX	UNIT
Static (Note 4)						
Drain-Source Breakdown Voltage	$V_{GS} = 0V, I_D = 250\mu\text{A}$	BV_{DSS}	450	--	--	V
Gate Threshold Voltage	$V_{DS} = V_{GS}, I_D = 250\mu\text{A}$	$V_{GS(TH)}$	2.3	--	4.25	V
Gate Body Leakage	$V_{GS} = \pm 30V, V_{DS} = 0V$	I_{GSS}	--	--	± 100	nA
Zero Gate Voltage Drain Current	$V_{DS} = 450V, V_{GS} = 0V$	I_{DSS}	--	--	10	μA
Drain-Source On-State Resistance	$V_{GS} = 10V, I_D = 0.25A$	$R_{DS(on)}$	--	3.7	4.25	Ω
Dynamic (Note 5)						
Total Gate Charge	$V_{DS} = 360V, I_D = 0.5A,$ $V_{GS} = 10V$	Q_g	--	6.5	10	nC
Gate-Source Charge		Q_{gs}	--	1.3	--	
Gate-Drain Charge		Q_{gd}	--	3.2	--	
Input Capacitance	$V_{DS} = 25V, V_{GS} = 0V,$ $f = 1.0\text{MHz}$	C_{iss}	--	235	--	pF
Output Capacitance		C_{oss}	--	29	--	
Reverse Transfer Capacitance		C_{rss}	--	6.5	--	
Switching (Note 6)						
Turn-On Delay Time	$V_{DD} = 225V,$ $R_{GEN} = 25\Omega,$ $I_D = 0.5A, V_{GS} = 10V,$	$t_{d(on)}$	--	14.7	--	ns
Turn-On Rise Time		t_r	--	32.8	--	
Turn-Off Delay Time		$t_{d(off)}$	--	25.2	--	
Turn-Off Fall Time		t_f	--	23.7	--	
Source-Drain Diode (Note 4)						
Maximum Continuous Drain-Source Diode Forward Current		I_S	--	--	0.5	A
Maximum Pulsed Drain-Source Diode Forward Current		I_{SM}	--	--	4	A
Forward On Voltage	$I_S = 0.5A, V_{GS} = 0V$	V_{SD}	--	--	1.4	V
Reverse Recovery Time	$V_{GS} = 0V, I_S = 1A$	t_{rr}	--	110	--	ns
Reverse Recovery Charge	$di_F/dt = 100A/\mu\text{s}$	Q_{rr}	--	0.35	--	μC

Notes:

1. Current limited by package.
2. Pulse width limited by the maximum junction temperature.
3. $L = 75\text{mH}, I_{AS} = 1.6A, V_{DD} = 50V, R_G = 25\Omega,$ Starting $T_J = 25^\circ\text{C}$
4. Pulse test: $PW \leq 300\mu\text{s},$ duty cycle $\leq 2\%$.
5. For DESIGN AID ONLY, not subject to production testing.
6. Switching time is essentially independent of operating temperature.

ORDERING INFORMATION

PART NO.	PACKAGE	PACKING
TSM1N45CT B0G	TO-92	1,000pcs / Bulk
TSM1N45CT A3G	TO-92	2,000pcs / Ammo
TSM1N45CW RPG	SOT-223	2,500pcs / 13" Reel

Not Recommended

CHARACTERISTICS CURVES

($T_C = 25^\circ\text{C}$ unless otherwise noted)

Output Characteristics

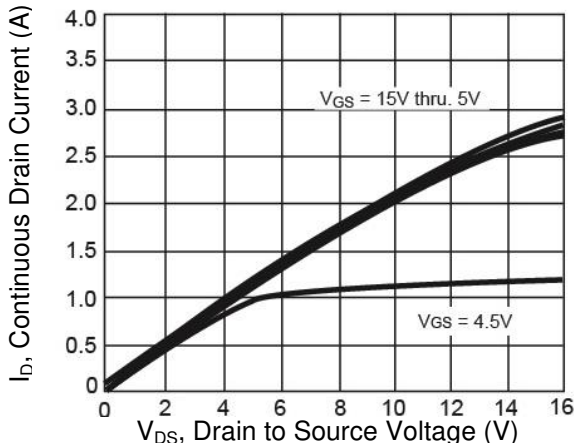

Transfer Characteristics

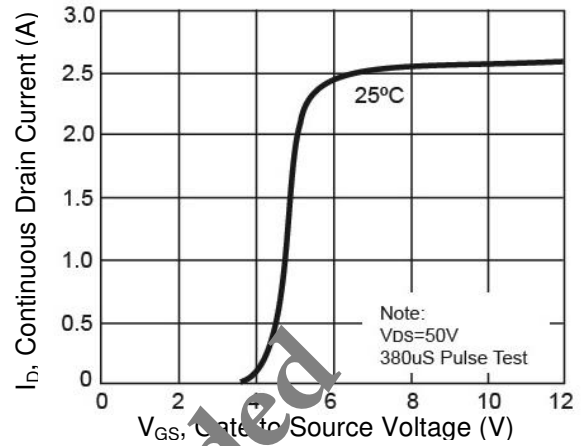

On-Resistance vs. Drain Current

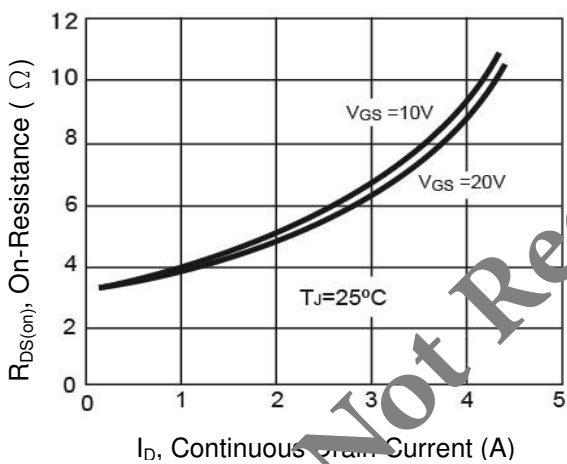

Gate-Source Voltage vs. Gate Charge

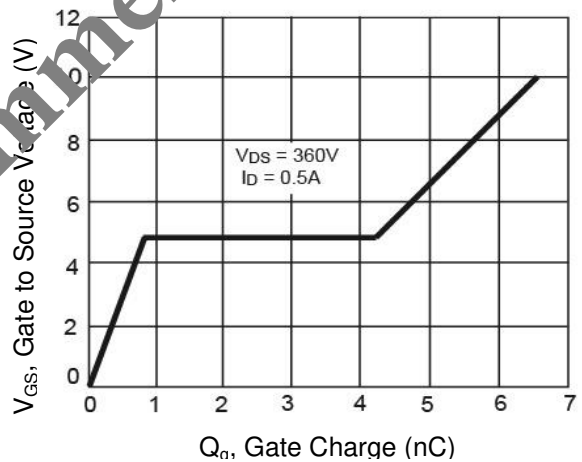

On-Resistance vs. Junction Temperature

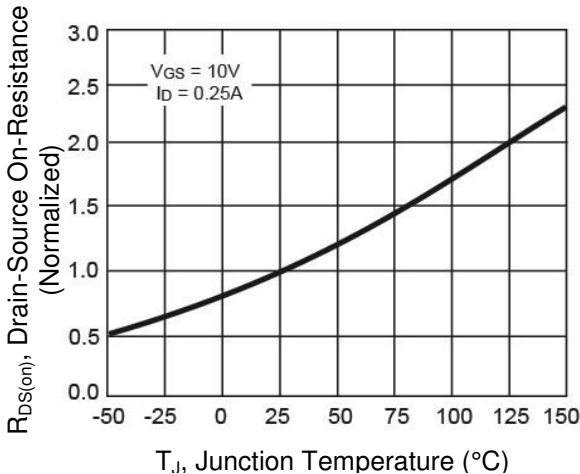

Source-Drain Diode Forward Current vs. Voltage

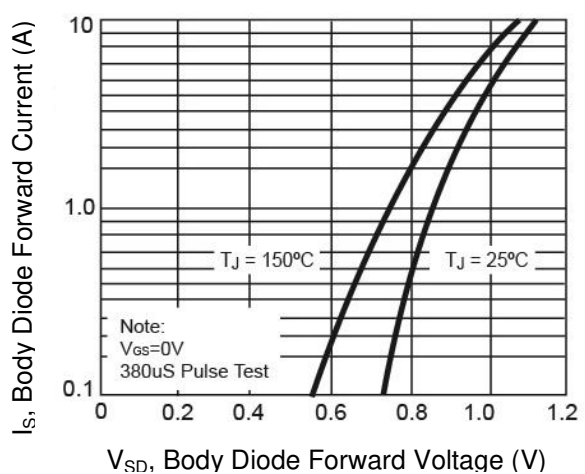

CHARACTERISTICS CURVES

($T_C = 25^\circ\text{C}$ unless otherwise noted)

On-Resistance vs. Gate-Source Voltage

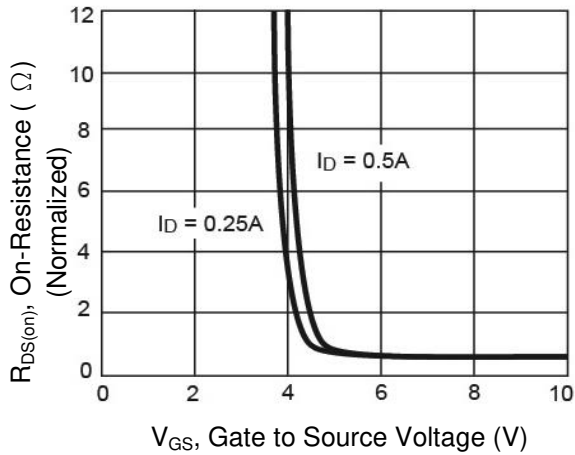

Threshold Voltage

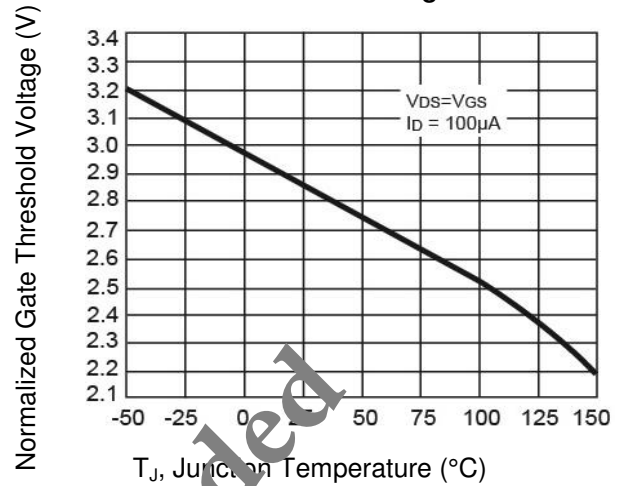

Maximum Safe Operating Area

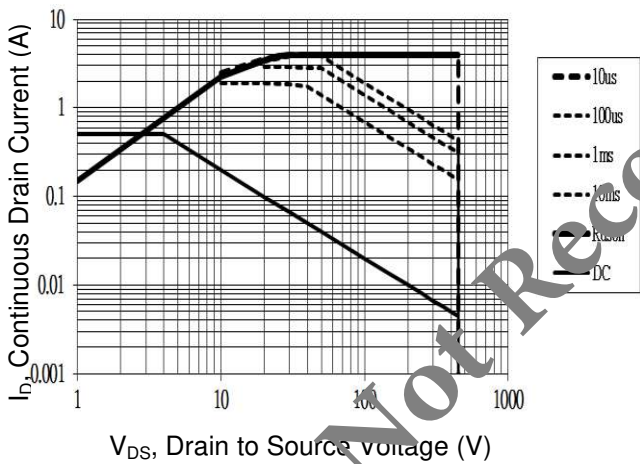

Thermal Transient Impedance, Junction-to-Ambient

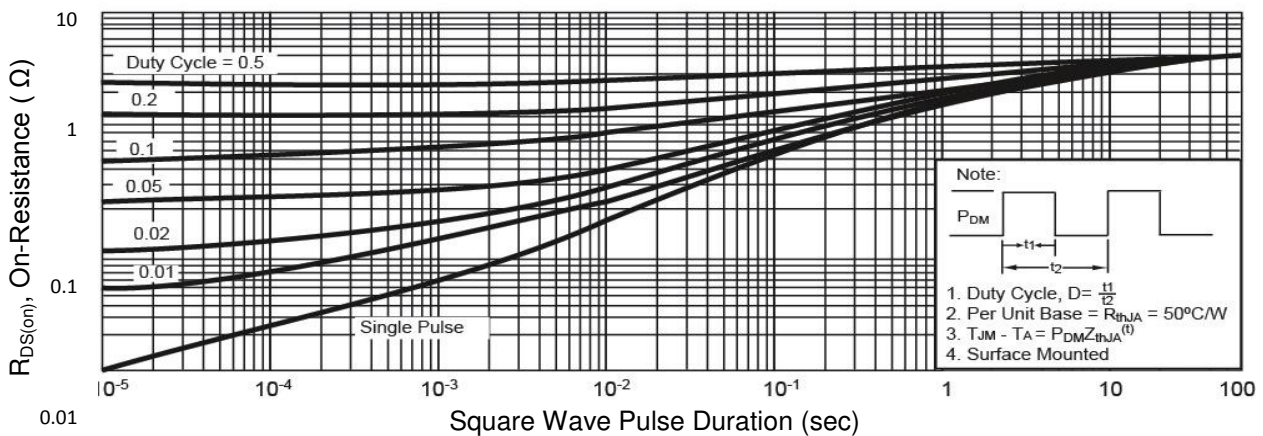

PACKAGE OUTLINE DIMENSIONS (Unit: Millimeters)

TO-92

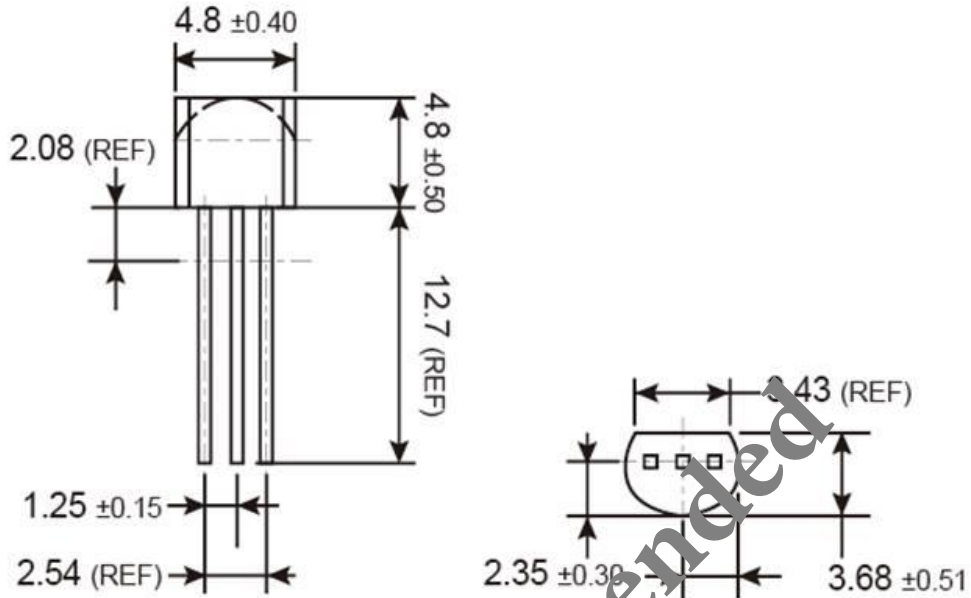

MARKING DIAGRAM



- Y** = Year Code
- M** = Month Code for Halogen Free Product
 - O** =Jan **F** =Feb **Q** =Mar **R** =Apr
 - S** =May **T** =Jun **U** =Jul **V** =Aug
 - W** =Sep **X** =Oct **Y** =Nov **Z** =Dec
- L** = Lot Code

PACKAGE OUTLINE DIMENSIONS (Unit: Millimeters)

TO-92

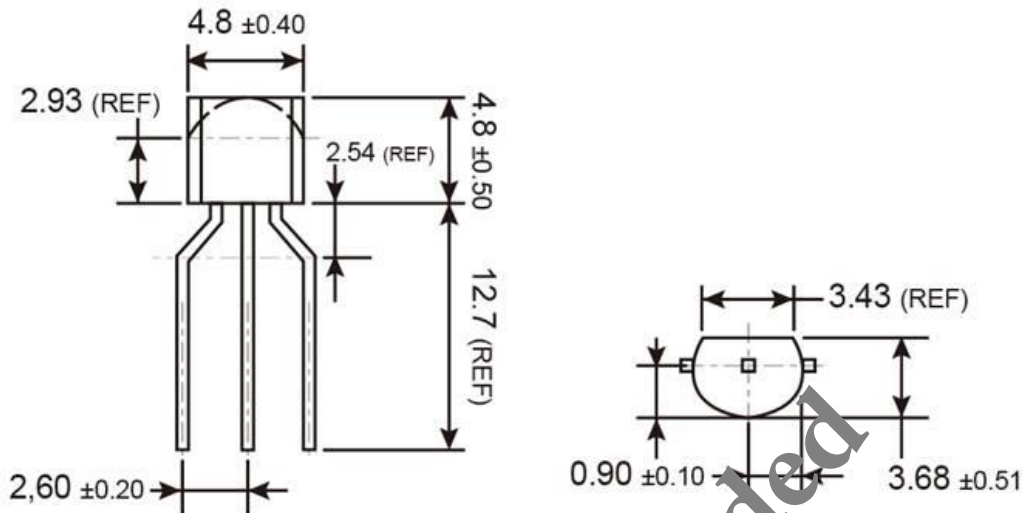

MARKING DIAGRAM



- Y** = Year Code
- M** = Month Code for Halogen Free Product
 - O** =Jan **P** =Feb **Q** =Mar **R** =Apr
 - S** =May **T** =Jun **U** =Jul **V** =Aug
 - W** =Sep **X** =Oct **Y** =Nov **Z** =Dec
- L** = Lot Code

PACKAGE OUTLINE DIMENSIONS (Unit: Millimeters)

SOT-223

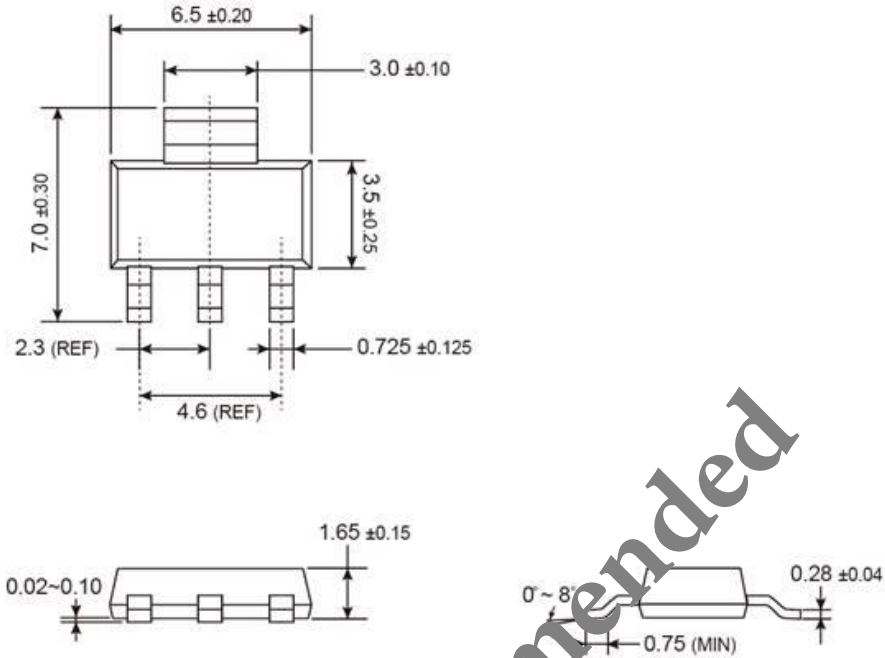

SUGGESTED PAD LAYOUT

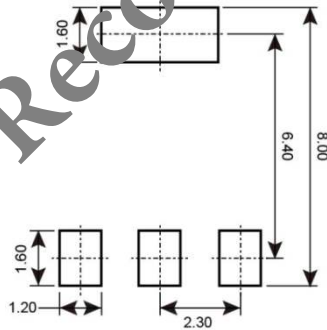

MARKING DIAGRAM

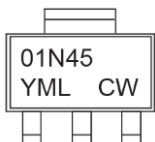

Y = Year Code
M = Month Code for Halogen Free Product
O =Jan **P** =Feb **Q** =Mar **R** =Apr
S =May **T** =Jun **U** =Jul **V** =Aug
W =Sep **X** =Oct **Y** =Nov **Z** =Dec
L = Lot Code

Not Recommended

Notice

Specifications of the products displayed herein are subject to change without notice. TSC or anyone on its behalf, assumes no responsibility or liability for any errors or inaccuracies.

Information contained herein is intended to provide a product description only. No license, express or implied, to any intellectual property rights is granted by this document. Except as provided in TSC's terms and conditions of sale for such products, TSC assumes no liability whatsoever, and disclaims any express or implied warranty, relating to sale and/or use of TSC products including liability or warranties relating to fitness for a particular purpose, merchantability, or infringement of any patent, copyright, or other intellectual property right.

The products shown herein are not designed for use in medical, life-saving, or life-sustaining applications. Customers using or selling these products for use in such applications do so at their own risk and agree to fully indemnify TSC for any damages resulting from such improper use or sale.