

Evaluating the **ADAU1472** SigmaDSP Digital Audio Processor

FEATURES

On-board [ADAU1761](#) codec with 2 analog inputs and 4 analog outputs
Stereo S/PDIF input
Stereo S/PDIF output
Self boot serial flash memory

EVALUATION KIT CONTENTS

EVAL-ADAU1472Z evaluation board
AC to 5 V dc power supply

EQUIPMENT NEEDED

PC running Windows® 7 or Windows 10
Tin Can Tools Flyswatter2 JTAG in-circuit debugger
Tin Can Tools OnCE 14-pin JTAG adapter board
Raspberry Pi 3 Model B+
Analog, stereo audio source with an output cable terminated with a 3.5 mm (1/8 inch) plug (for analog input)
Desktop speakers or an audio input with a cable terminated with a 3.5 mm (1/8 inch) plug (for analog output)
Headphones with a cable terminated with a 3.5 mm (1/8 inch) plug (for headphone output)
[EVAL-ADUSB2EBZ](#) communications adapter (USBi)
Lattice HW-USBN-2B FPGA programming cable (if FPGA reconfiguration is desired)

SOFTWARE NEEDED

Lattice FPGA programming software (if FPGA reconfiguration is desired)

DOCUMENTS NEEDED

ADAU1472 data sheet
ADAU1761 data sheet

GENERAL DESCRIPTION

This user guide describes the design, setup, and operation of the EVAL-ADAU1472Z evaluation board, which allows users to evaluate the ADAU1472 SigmaDSP® digital audio processor.

The EVAL-ADAU1472Z provides access to the digital serial audio ports of the ADAU1472 and some of the general-purpose input and outputs (GPIOs). The analog input and output is provided by the ADAU1761 codec included on the EVAL-ADAU1472Z.

The ADAU1472 can be configured in a variety of ways. The on-board serial flash memory can be programmed for self boot mode.

The EVAL-ADAU1472Z is powered by a 5 V dc supply, which is regulated to the voltages required on the board. The printed circuit board (PCB) is a 4-layer design with a ground plane and a power plane on the inner layers. The EVAL-ADAU1472Z includes connectors for external analog inputs and outputs and optical Sony/Philips digital interface (S/PDIF) interfaces.

For full details on the ADAU1472 and the ADAU1761, see the ADAU1472 and ADAU1761 data sheets, which must be used in conjunction with this user guide when using the EVAL-ADAU1472Z evaluation board.

TABLE OF CONTENTS

Features	1	Revision History	2
Evaluation Kit Contents.....	1	EVAL-ADAU1472Z Evaluation Board Photographs.....	3
Equipment Needed.....	1	Evaluation Board Hardware.....	4
Software Needed	1	Evaluation Board Software.....	6
Documents Needed.....	1		
General Description.....	1		

REVISION HISTORY

4/2021—Revision 0: Initial Version

EVAL-ADAU1472Z EVALUATION BOARD PHOTOGRAPHS



23146-001

Figure 1. EVAL-ADAU1472Z Evaluation Board (Top Side)

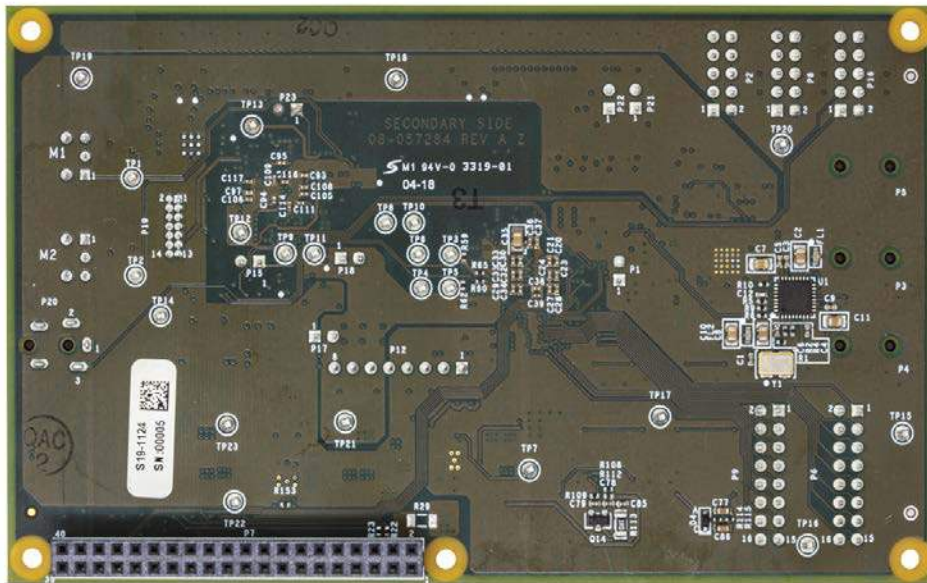

23146-002

Figure 2. EVAL-ADAU1472Z Evaluation Board (Bottom Side)

EVALUATION BOARD HARDWARE

Figure 3 shows a block diagram of the EVAL-ADAU1472Z evaluation board platform. The ADAU1472 receives digital audio from the on-board ADAU1761 and outputs and transmits

digital audio using the ADAU1761. Table 1 describes the EVAL-ADAU1472Z evaluation board hardware components.

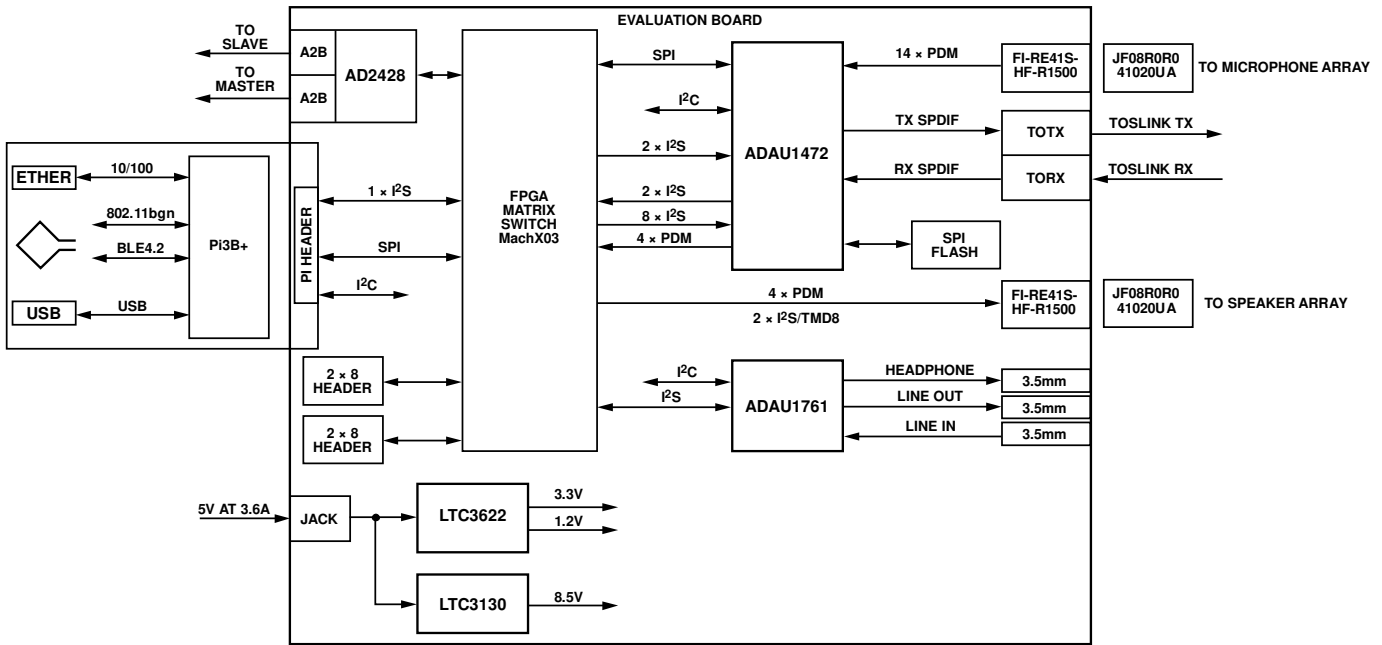

Figure 3. EVAL-ADAU1472Z Hardware Block Diagram

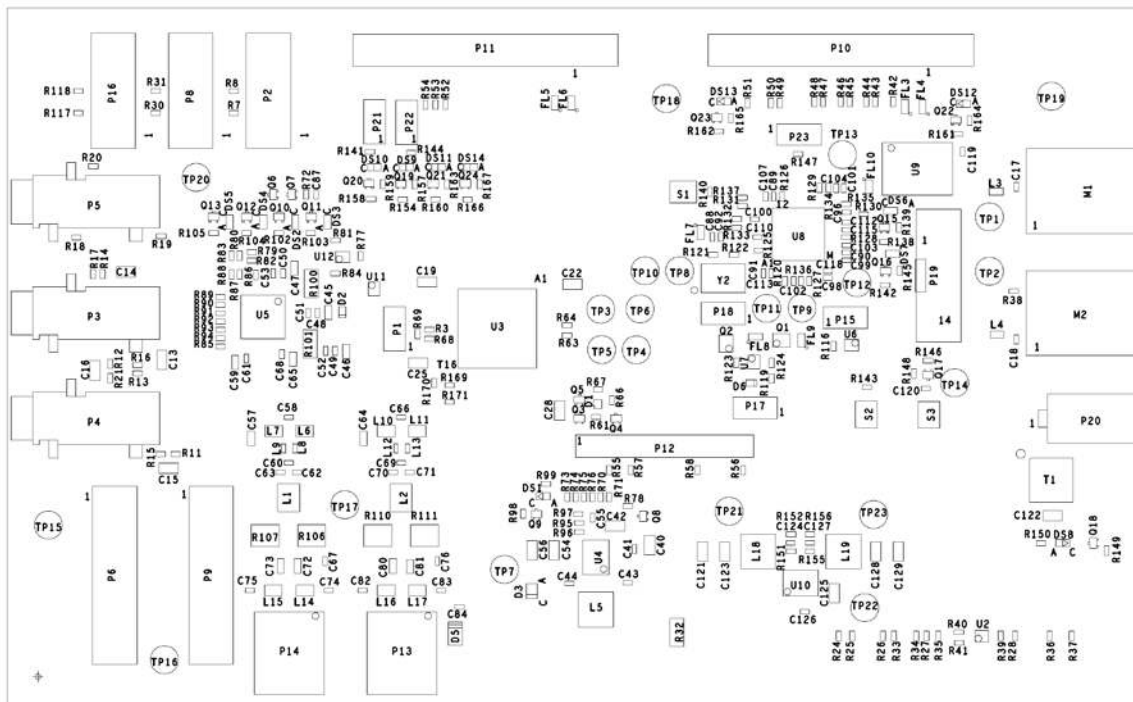

Figure 4. EVAL-ADAU1472Z PCB Assembly Drawing (Top Side)

Table 1. EVAL-ADAU1472Z Evaluation Board Hardware Components

Reference Designator	Function	Description
P20	Power connector	The 5 V at 3.6 A power supply is connected at P20.
DS8	LED indicator for 5 V	When this LED is on, it indicates the 5 V power rail is present.
DS13	LED indicator for 3.3 V	When this LED is on, it indicates the 3.3 V power rail is present.
DS12	LED indicator for 1.2 V	When this LED is on, it indicates the 1.2 V power rail is present.
DS1	LED indicator for 8.5 V	When this LED is on, it indicates the 8.5 V power rail is present.
S3	ADAU1472 reset	This push-button switch resets the ADAU1472 processor.
S1	Push-Button 1	This push-button switch is connected to GPIO0 on the ADAU1472.
S2	Push-Button 2	This push-button switch is connected to GPIO1 on the ADAU1472.
P19	ADAU1472 JTAG	Connect a Joint Test Action Group (JTAG) emulator at J16 to step through the ADAU1472 source code.
P16	USBi connector	An EVAL-ADUSB2EBZ communications adapter (USBi) can be connected to this connector.
DS9	LED0	This LED is connected to the LED_0 pin on the FPGA and is currently unused.
DS10	LED1	This LED is connected to the LED_1 pin on the FPGA and is currently used as a FPGA heartbeat indicator.
DS11	LED2	This LED is connected to the LED_2 pin on the FPGA and is currently unused.
DS14	LED3	This LED is connected to the LED_3 pin on the FPGA and is currently unused.
DS6	LED4	This LED is connected to the GPIO4 pin on the ADAU1472.
DS7	LED5	This LED is connected to the GPIO5 pin on the ADAU1472.
P4	LINE_IN	This connector is used for the line level, analog audio input (two channels).
P3	LINE_OUT	This connector is used for the line level, analog audio output (two channels).
P5	HEADPHONE_OUT	This connector is used for the headphone level, analog audio output (two channels).
M2	S/PDIF (optical) RX	It is the S/PDIF (optical) RX connector for receiving digital audio from an S/PDIF (optical) transmitter.
M1	S/PDIF (optical) TX	It is the S/PDIF (optical) TX connector for transmitting digital audio to an S/PDIF (optical) receiver.
P10	Microphone array board connector	This connector is used to interface to a microphone array board.

Note that the schematics, layout, and bill of materials for the EVAL-ADAU1472Z evaluation board can be found within the Analog Devices, Inc., EngineerZone at [EVAL-ADAU1472Z Evaluation Board support files \(public\)](#).

EVALUATION BOARD SOFTWARE

In order for the EVAL-ADAU1472Z evaluation board to function correctly, the following two devices must be configured and programmed in a compatible manner:

- ADAU1472 SigmaDSP digital audio processor (U8)
- Lattice Semiconductor® LCMXO3L-1300E field programmable gate array (FPGA) (U3)

The software packages for the EVAL-ADAU1472Z evaluation board must be requested through a local Analog Devices sales or distribution representative.



ESD Caution

ESD (electrostatic discharge) sensitive device. Charged devices and circuit boards can discharge without detection. Although this product features patented or proprietary protection circuitry, damage may occur on devices subjected to high energy ESD. Therefore, proper ESD precautions should be taken to avoid performance degradation or loss of functionality.

Legal Terms and Conditions

By using the evaluation board discussed herein (together with any tools, components documentation or support materials, the "Evaluation Board"), you are agreeing to be bound by the terms and conditions set forth below ("Agreement") unless you have purchased the Evaluation Board, in which case the Analog Devices Standard Terms and Conditions of Sale shall govern. Do not use the Evaluation Board until you have read and agreed to the Agreement. Your use of the Evaluation Board shall signify your acceptance of the Agreement. This Agreement is made by and between you ("Customer") and Analog Devices, Inc. ("ADI"), with its principal place of business at One Technology Way, Norwood, MA 02062, USA. Subject to the terms and conditions of the Agreement, ADI hereby grants to Customer a free, limited, personal, temporary, non-exclusive, non-sublicensable, non-transferable license to use the Evaluation Board FOR EVALUATION PURPOSES ONLY. Customer understands and agrees that the Evaluation Board is provided for the sole and exclusive purpose referenced above, and agrees not to use the Evaluation Board for any other purpose. Furthermore, the license granted is expressly made subject to the following additional limitations: Customer shall not (i) rent, lease, display, sell, transfer, assign, sublicense, or distribute the Evaluation Board; and (ii) permit any Third Party to access the Evaluation Board. As used herein, the term "Third Party" includes any entity other than ADI, Customer, their employees, affiliates and in-house consultants. The Evaluation Board is NOT sold to Customer; all rights not expressly granted herein, including ownership of the Evaluation Board, are reserved by ADI. CONFIDENTIALITY. This Agreement and the Evaluation Board shall all be considered the confidential and proprietary information of ADI. Customer may not disclose or transfer any portion of the Evaluation Board to any other party for any reason. Upon discontinuation of use of the Evaluation Board or termination of this Agreement, Customer agrees to promptly return the Evaluation Board to ADI. ADDITIONAL RESTRICTIONS. Customer may not disassemble, decompile or reverse engineer chips on the Evaluation Board. Customer shall inform ADI of any occurred damages or any modifications or alterations it makes to the Evaluation Board, including but not limited to soldering or any other activity that affects the material content of the Evaluation Board. Modifications to the Evaluation Board must comply with applicable law, including but not limited to the RoHS Directive. TERMINATION. ADI may terminate this Agreement at any time upon giving written notice to Customer. Customer agrees to return to ADI the Evaluation Board at that time. LIMITATION OF LIABILITY. THE EVALUATION BOARD PROVIDED HEREUNDER IS PROVIDED "AS IS" AND ADI MAKES NO WARRANTIES OR REPRESENTATIONS OF ANY KIND WITH RESPECT TO IT. ADI SPECIFICALLY DISCLAIMS ANY REPRESENTATIONS, ENDORSEMENTS, GUARANTEES, OR WARRANTIES, EXPRESS OR IMPLIED, RELATED TO THE EVALUATION BOARD INCLUDING, BUT NOT LIMITED TO, THE IMPLIED WARRANTY OF MERCHANTABILITY, TITLE, FITNESS FOR A PARTICULAR PURPOSE OR NON-INFRINGEMENT OF INTELLECTUAL PROPERTY RIGHTS. IN NO EVENT WILL ADI AND ITS LICENSORS BE LIABLE FOR ANY INCIDENTAL, SPECIAL, INDIRECT, OR CONSEQUENTIAL DAMAGES RESULTING FROM CUSTOMER'S POSSESSION OR USE OF THE EVALUATION BOARD, INCLUDING BUT NOT LIMITED TO LOST PROFITS, DELAY COSTS, LABOR COSTS OR LOSS OF GOODWILL. ADI'S TOTAL LIABILITY FROM ANY AND ALL CAUSES SHALL BE LIMITED TO THE AMOUNT OF ONE HUNDRED US DOLLARS (\$100.00). EXPORT. Customer agrees that it will not directly or indirectly export the Evaluation Board to another country, and that it will comply with all applicable United States federal laws and regulations relating to exports. GOVERNING LAW. This Agreement shall be governed by and construed in accordance with the substantive laws of the Commonwealth of Massachusetts (excluding conflict of law rules). Any legal action regarding this Agreement will be heard in the state or federal courts having jurisdiction in Suffolk County, Massachusetts, and Customer hereby submits to the personal jurisdiction and venue of such courts. The United Nations Convention on Contracts for the International Sale of Goods shall not apply to this Agreement and is expressly disclaimed.