

PRODUCT NUMBER	TAIL PLATING OPTION, SEE NOTE 2	DESCRIPTION
10112627-101	OPTION 1	WITHOUT STOPS
10112627-101LF	OPTION 2	WITHOUT STOPS
10112627-102	OPTION 1	WITH STOPS
10112627-102LF	OPTION 2	WITH STOPS

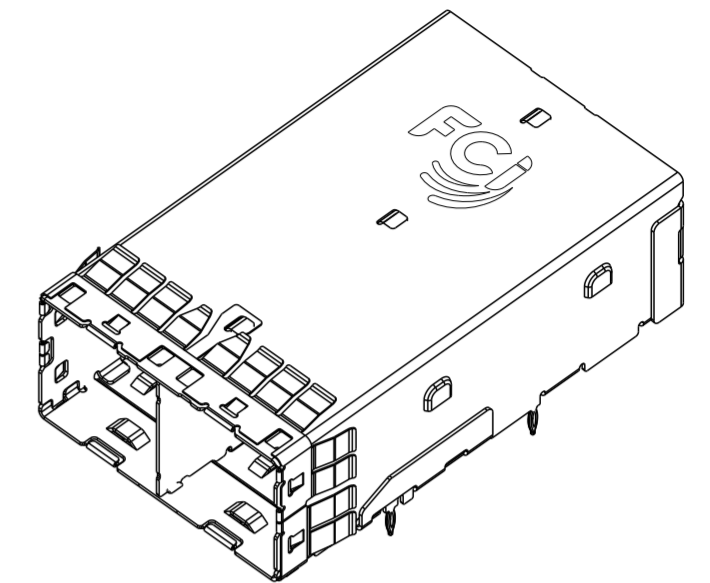

10112627-101 & 101LF  
WITHOUT STOPS

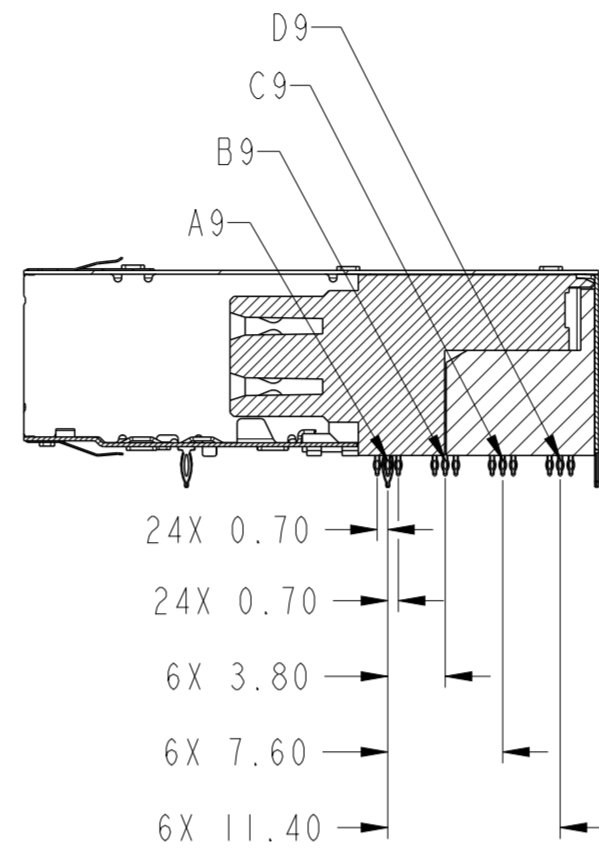
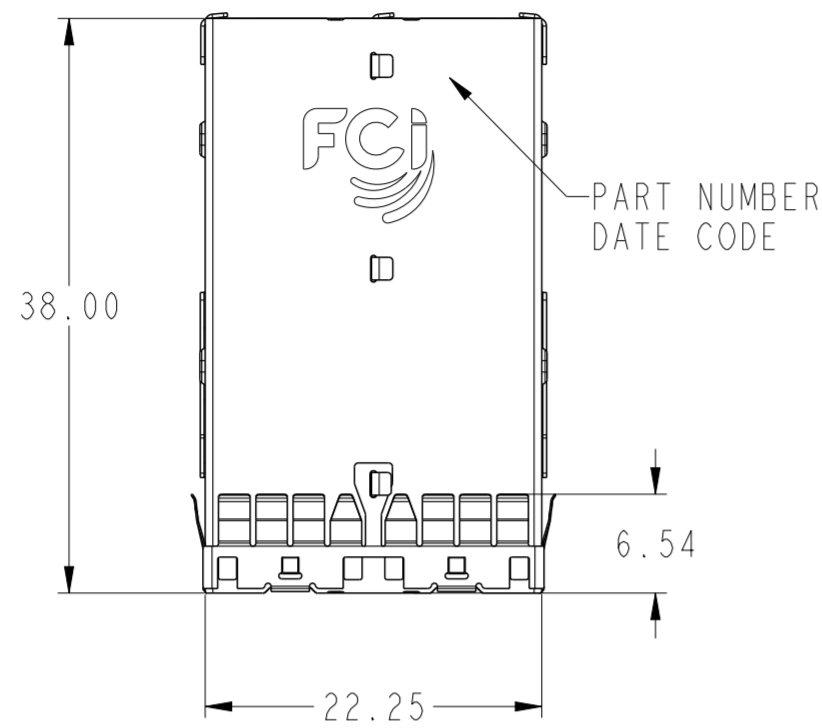
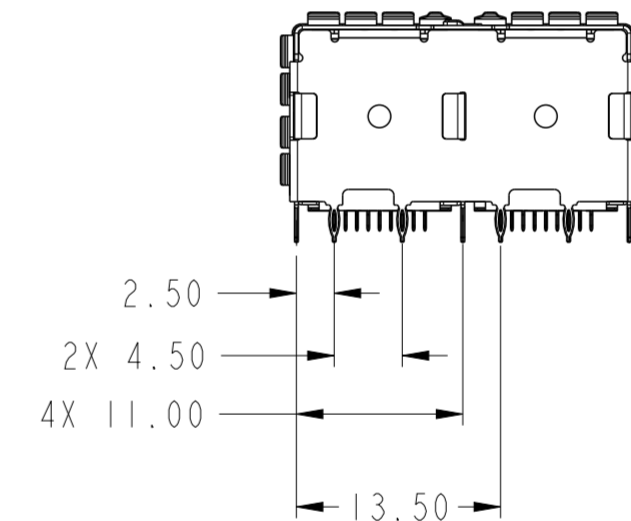
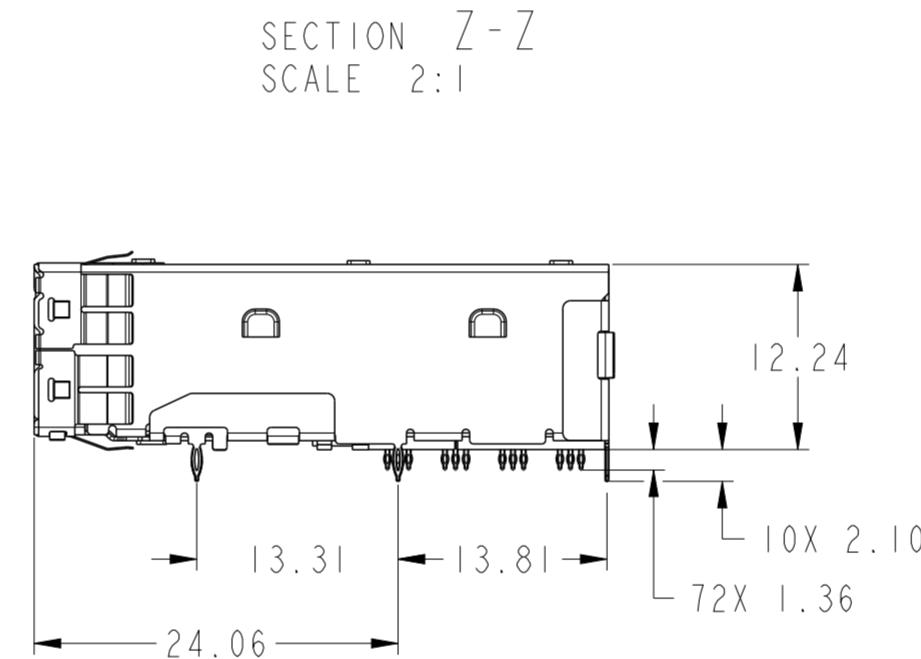
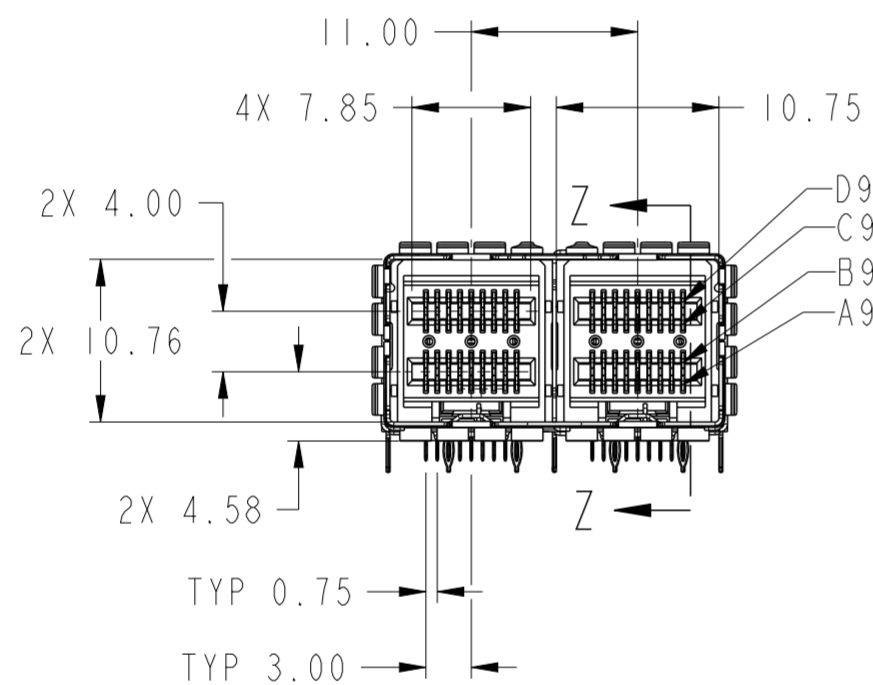

NOTES:

- MATERIALS:  
CONNECTOR HOUSING: HIGH TEMPERATURE THERMOPLASTIC  
GLASS FILLED, UL 94V-0  
EMI CAGE: NICKEL SILVER ALLOY  
EMI FINGERS: COPPER ALLOY  
TERMINALS: COPPER ALLOY
- FINISHES:  
EMI FINGERS: 0.50µm MIN NICKEL  
CONTACT AREA: 0.76µm MIN GOLD OVER 2.54µm MIN NICKEL  
TAIL AREA:  
OPTION 1: 0.76µm - 1.52µm TIN/LEAD (90/10) OVER 2.54µm MIN NICKEL  
OPTION 2: 0.76µm - 1.52µm TIN (LEAD FREE) OVER 2.54µm MIN NICKEL
- PRODUCT SPECIFICATION: GS-12-651.  
APPLICATION SPECIFICATION: GS-20-0327
- MOUNTING HARDWARE: M2X0.4 BUTTON HEAD SCREW  
MOUNTING SCREW LENGTH: BOARD THICKNESS + 1.4mm MAX (0.9mm MIN).  
2 REQUIRED PER ASSEMBLY
- THIS CONNECTOR IS DESIGNED TO MEET THE REQUIREMENTS OF  
INDUSTRY SPECIFICATION SFF-8644.
- THE USE OF A PCI BRACKET OR EQUIVALENT IS REQUIRED FOR THIS PRODUCT
- A SYMBOL WILL BE NEXT TO ANY DIMENSION, VIEW, OR NOTE THAT  
HAS BEEN MODIFIED WITH THE CURRENT DRAWING REVISION.

MATES WITH MINI-SAS HD ENDS IN:
10112041 SERIES (4X)
10117771 SERIES (4X)
10117946 SERIES (4X)
10117949 SERIES (4X)
10117947 SERIES (8X)
10112359 SERIES (8X)
10117950 SERIES (8X)
10117948 SERIES (8X)

spec ref	-	dr	Mark Gray	2010/08/04	projection	MM	size	A2	scale	2:1									
tolerance std	ASME Y14.5	eng	M Scholeno	2012/09/10			ecn no	ELX-V-012260-1	rel level	Released									
TOLERANCES UNLESS OTHERWISE SPECIFIED		chr	-	apppr							Brad Brubaker	2012/09/12	product family	MINI-SAS HD					
surface	<table border="1"> <tr> <td>linear</td> <td>0.X</td> <td>±0.25</td> </tr> <tr> <td></td> <td>0.XX</td> <td>±0.13</td> </tr> <tr> <td></td> <td>0.XXX</td> <td>±</td> </tr> <tr> <td>angular</td> <td>0°</td> <td>±1/2°</td> </tr> </table>	linear	0.X	±0.25		0.XX	±0.13		0.XXX	±	angular	0°	±1/2°			<b>TITLE</b> 1X2 EXTERNAL ASSEMBLY MINI-SAS HD		<b>dwg no</b> 10112627	<b>rev</b> D
linear	0.X	±0.25																	
	0.XX	±0.13																	
	0.XXX	±																	
angular	0°	±1/2°																	
ASME Y14.5	www.fci.com	cat. no.	-		Product - Customer Drw	sheet 1 of 7													

APPLICATION	DIM A
PCI ADD-IN CARD	19.00±0.15
ALL OTHER APPLICATIONS	20.08±0.15

I/O BRACKET CUT OUT  
(BRACKET NOT INCLUDED)  
SEE NOT 6

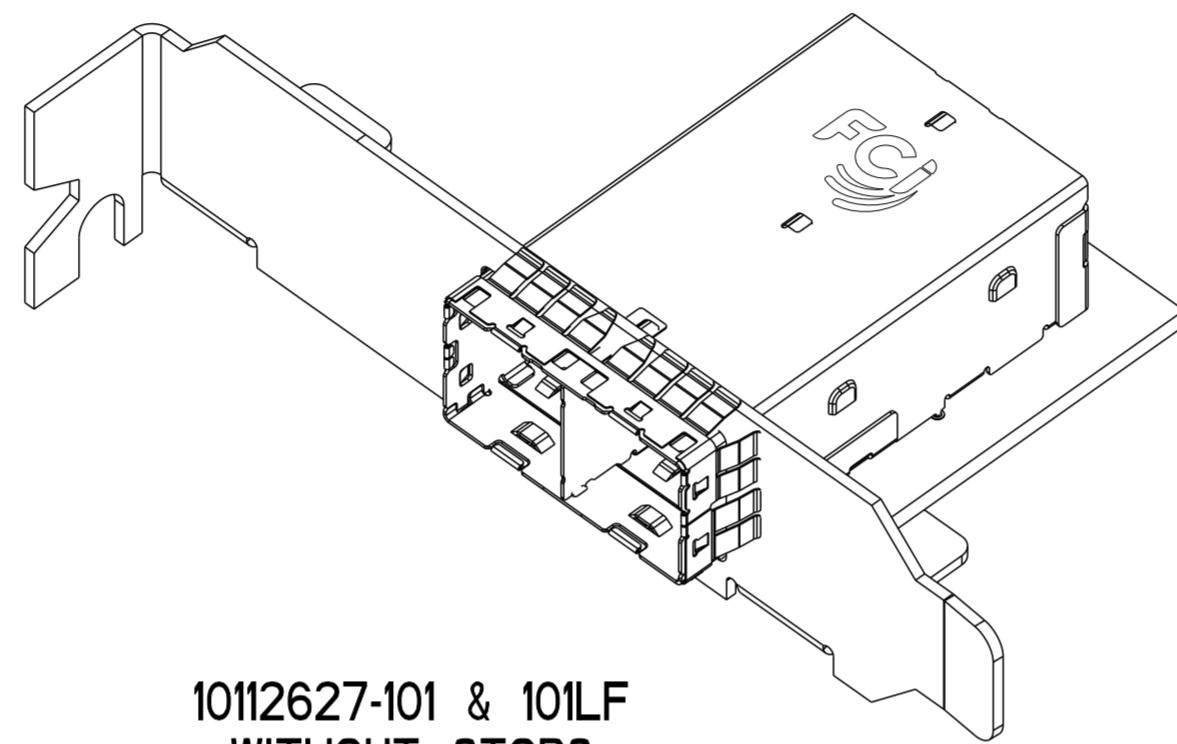

10112627-101 & 101LF  
WITHOUT STOPS  
SCALE 2:1

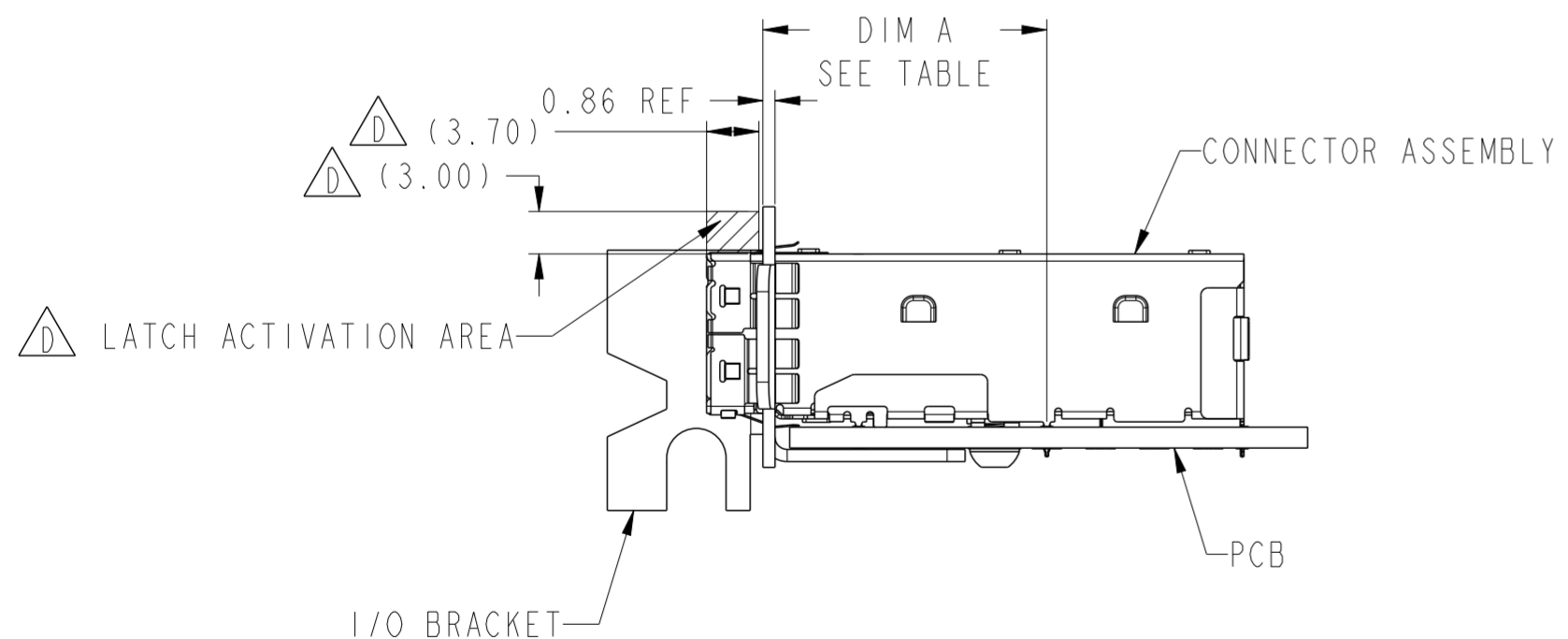

ASSEMBLED VIEW  
WITHOUT STOPS  
SCALE 2:1

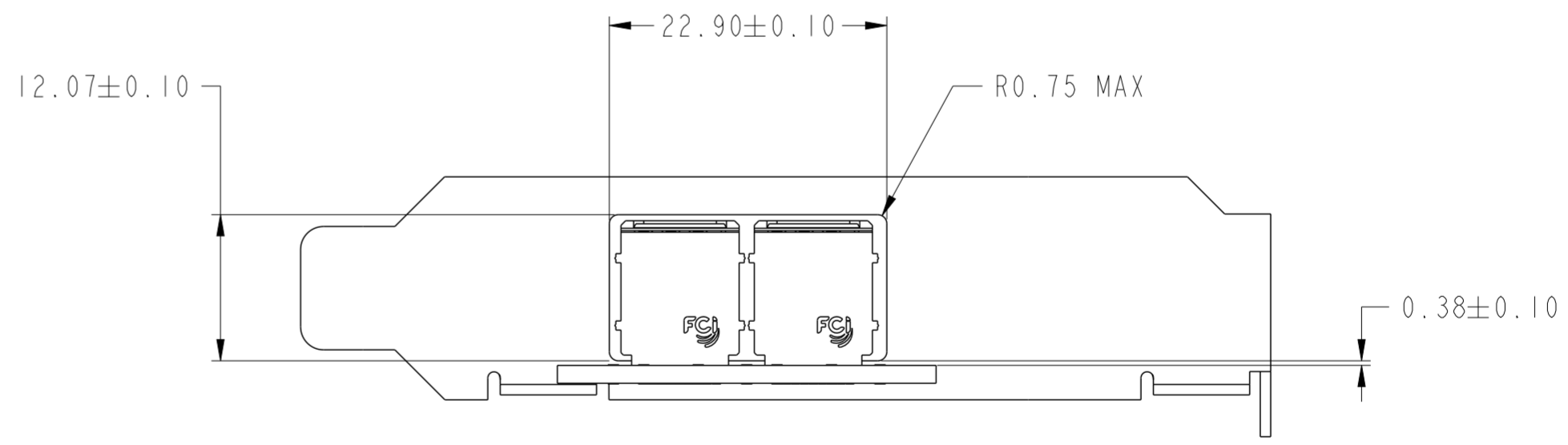

spec ref	-	dr	Mark Gray	2010/08/04	projection	MM	size	A2	scale	1:1	
tolerance std	ASME Y14.5	eng	M Scholeno	2012/09/10			ecn no	ELX-V-012260-1			
TOLERANCES UNLESS OTHERWISE SPECIFIED		chr	-	appr			Brad Brubaker	2012/09/12	product family	MINI-SAS HD	rel level
surface	✓	linear	0.X	±0.25		<b>IX2 EXTERNAL ASSEMBLY</b> MINI-SAS HD	dwg no 10112627	rev D	Product - Customer Drw		
		linear	0.XX	±0.13					cat. no.	-	sheet 2 of 7
		angular	0°	±1/2°							

Copyright FCI. FCI

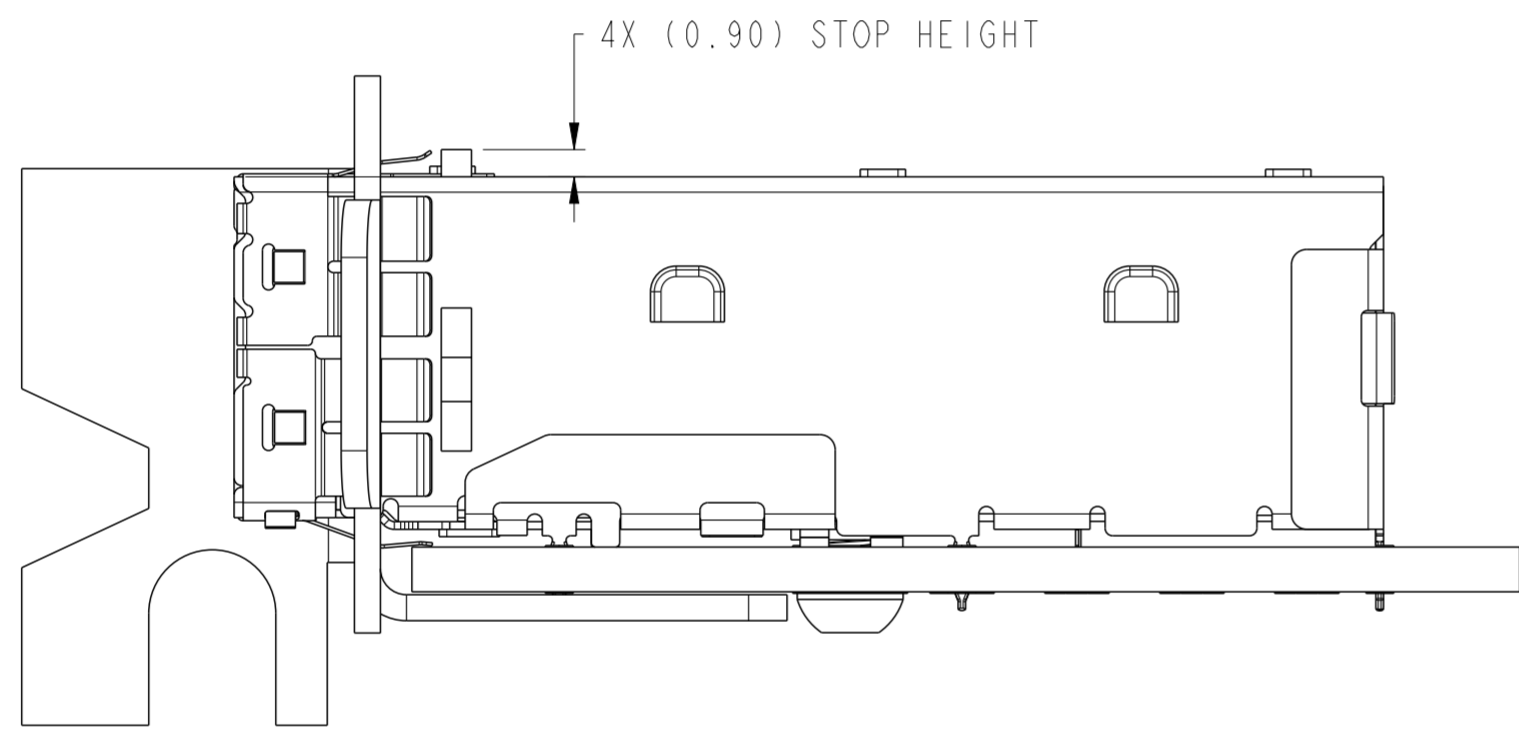

ASSEMBLED VIEW  
WITH STOPS  
SCALE 4:1

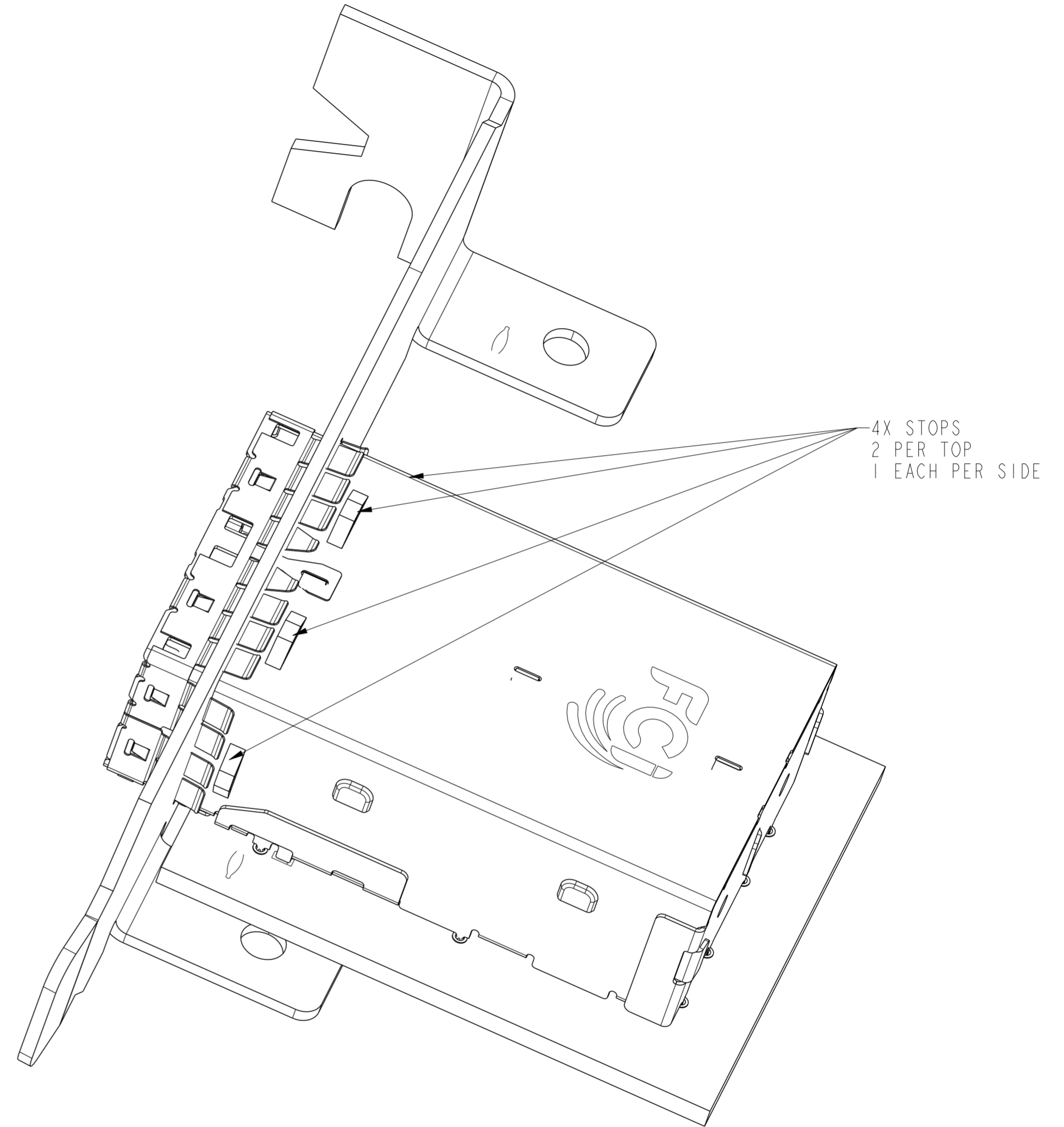

10112627-102 & 102LF  
WITH STOPS  
SCALE 4:1



Copyright FCI.

spec ref -		dr Mark Gray	2010/08/04	projection	MM	size A2	scale 1:1
tolerance std ASME Y14.5		eng M Scholeno	2012/09/10			ecn no ELX-V-012260-1	
TOLERANCES UNLESS OTHERWISE SPECIFIED		chr -	2012/09/12			product family MINI-SAS HD	rel level Released
surface ✓	ASME Y14.5	linear	0.X ±0.25		title IX2 EXTERNAL ASSEMBLY MINI-SAS HD	dwg no 10112627	rev D
			0.XX ±0.13				
		angular	0° ±1/2°				
www.fci.com		cat. no.		Product - Customer Drw		sheet 3 of 7	

APPLICATION	DIM B
PCI ADD-IN CARD	17.10±0.15
ALL OTHER APPLICATIONS	18.19±0.15

# RECOMMENDED BOARD LAYOUT

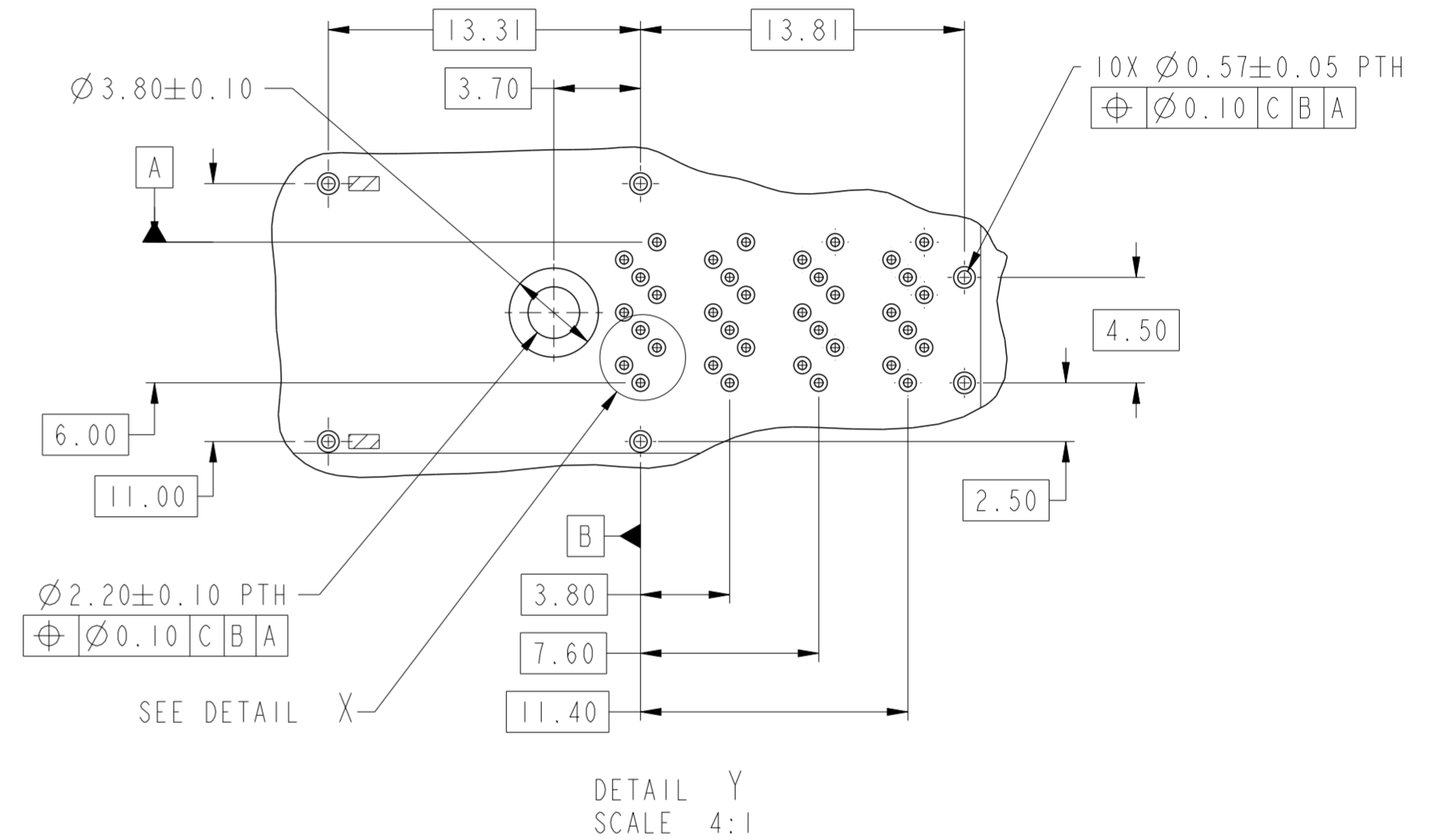
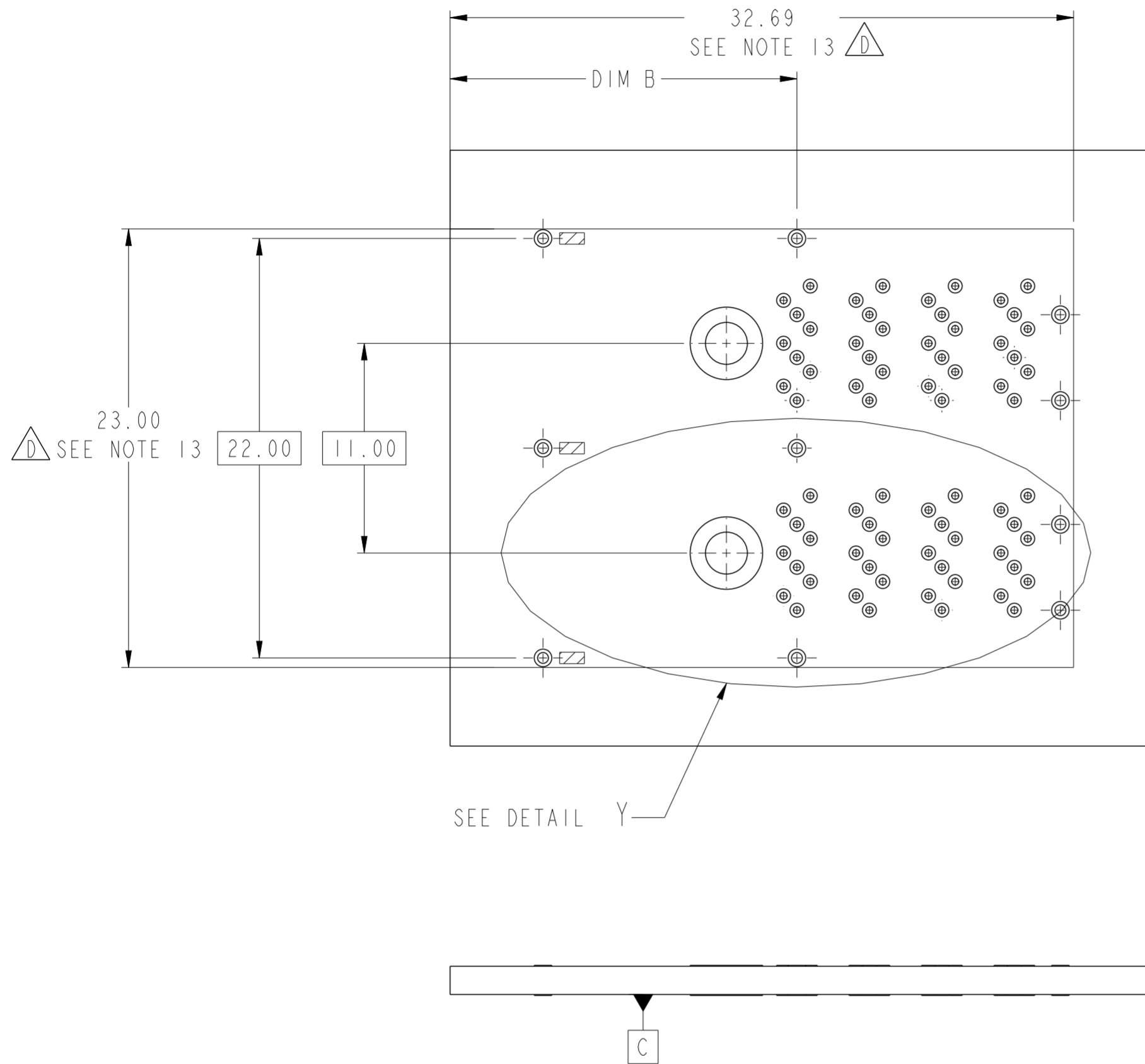

DETAIL Y  
SCALE 4:1

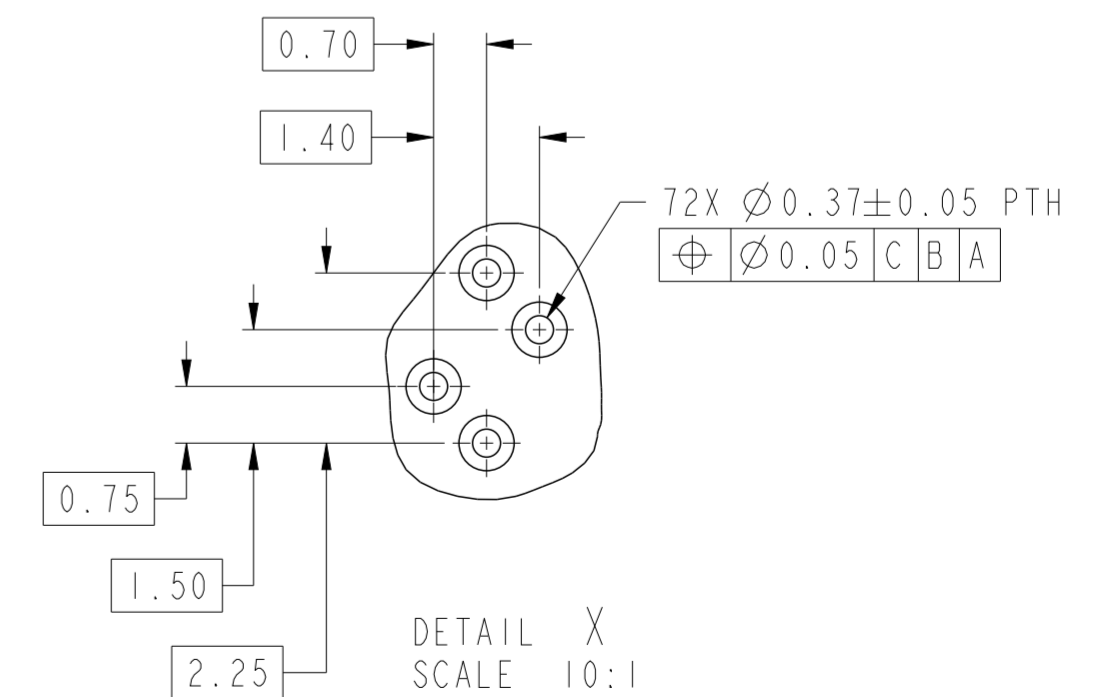

DETAIL X  
SCALE 10:1

NOTES:

- RECOMMENDED DRILL SIZE FOR A Ø0.37 FINISHED PTH IS Ø0.457.
- RECOMMENDED ANNULAR RING AROUND Ø0.37 FINISHED PTH IS Ø0.73.
- RECOMMENDED DRILL SIZE FOR A Ø0.57 FINISHED PTH IS Ø0.68.
- RECOMMENDED ANNULAR RING AROUND Ø0.57 FINISHED PTH IS Ø0.93.
- MINIMUM RECOMMENDED CENTER TO CENTER SPACING BETWEEN ADJACENT CONNECTORS: 25.00mm.
- CONNECTOR KEEP OUT AREA.
- MINIMUM PCB THICKNESS: 1.57mm.

spec ref	-	dr	Mark Gray	2010/08/04	projection	MM	size	A2	scale	1:1			
tolerance std	ASME Y14.5	eng	M Scholeno	2012/09/10			ecn no	ELX-V-012260-1	rel level	Released			
	TOLERANCES UNLESS OTHERWISE SPECIFIED	chr	-	appr							Brad Brubaker	2012/09/12	product family
surface	✓	linear	0.X	±0.25			title	IX2 EXTERNAL ASSEMBLY		dwg no	10112627	rev	D
			0.XX	±0.13	www.fci.com		cat. no.	-		Product - Customer Drw	sheet 4 of 7		
		angular	0°	±1/2°									

# RECOMMENDED TOOLING KEEP OUT AREAS

RECOMMENDED INSERTION TOOL  
KEEP OUT AREA  
NO COMPONENTS IN THIS AREA  
MORE THAN 7.50mm TALL

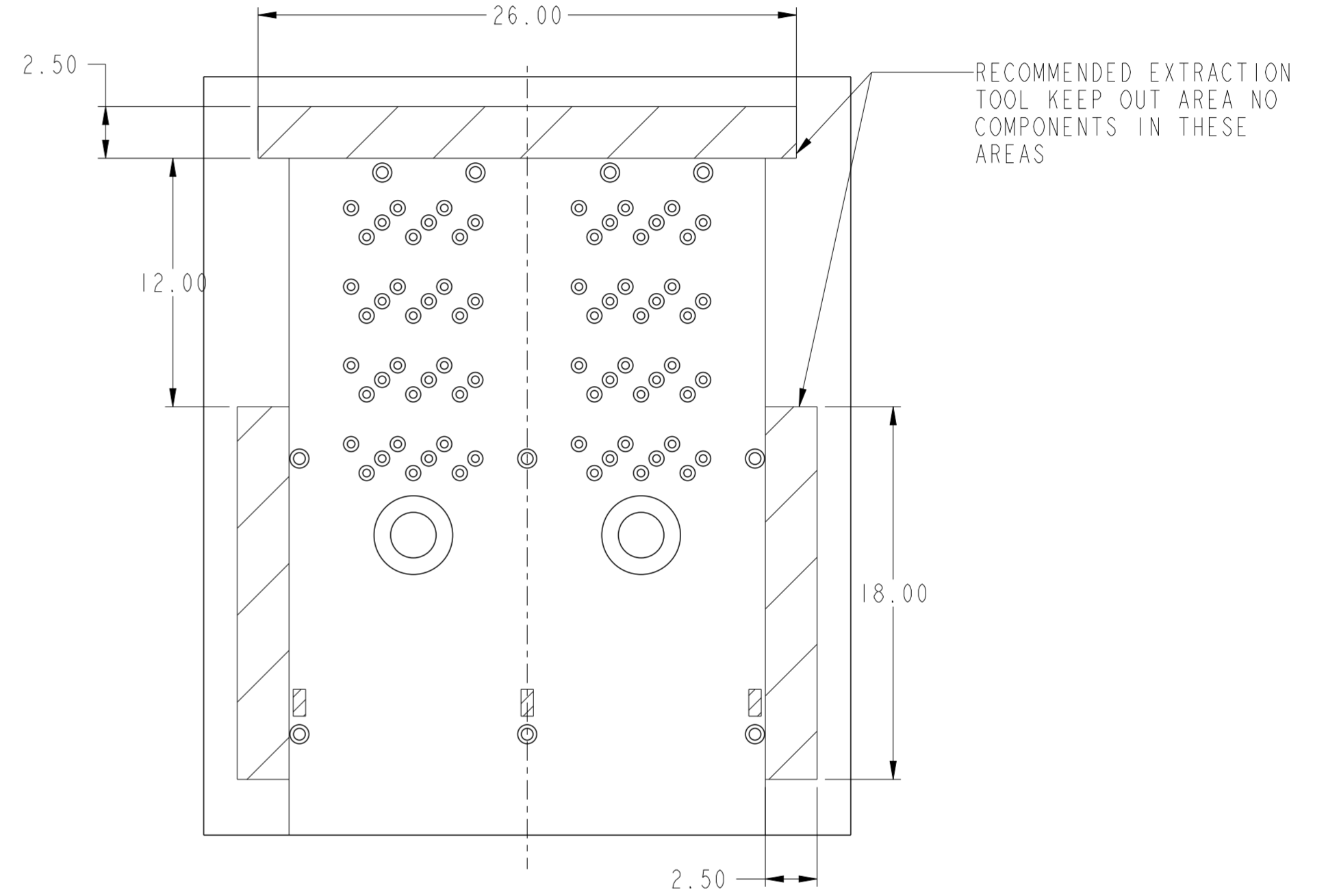
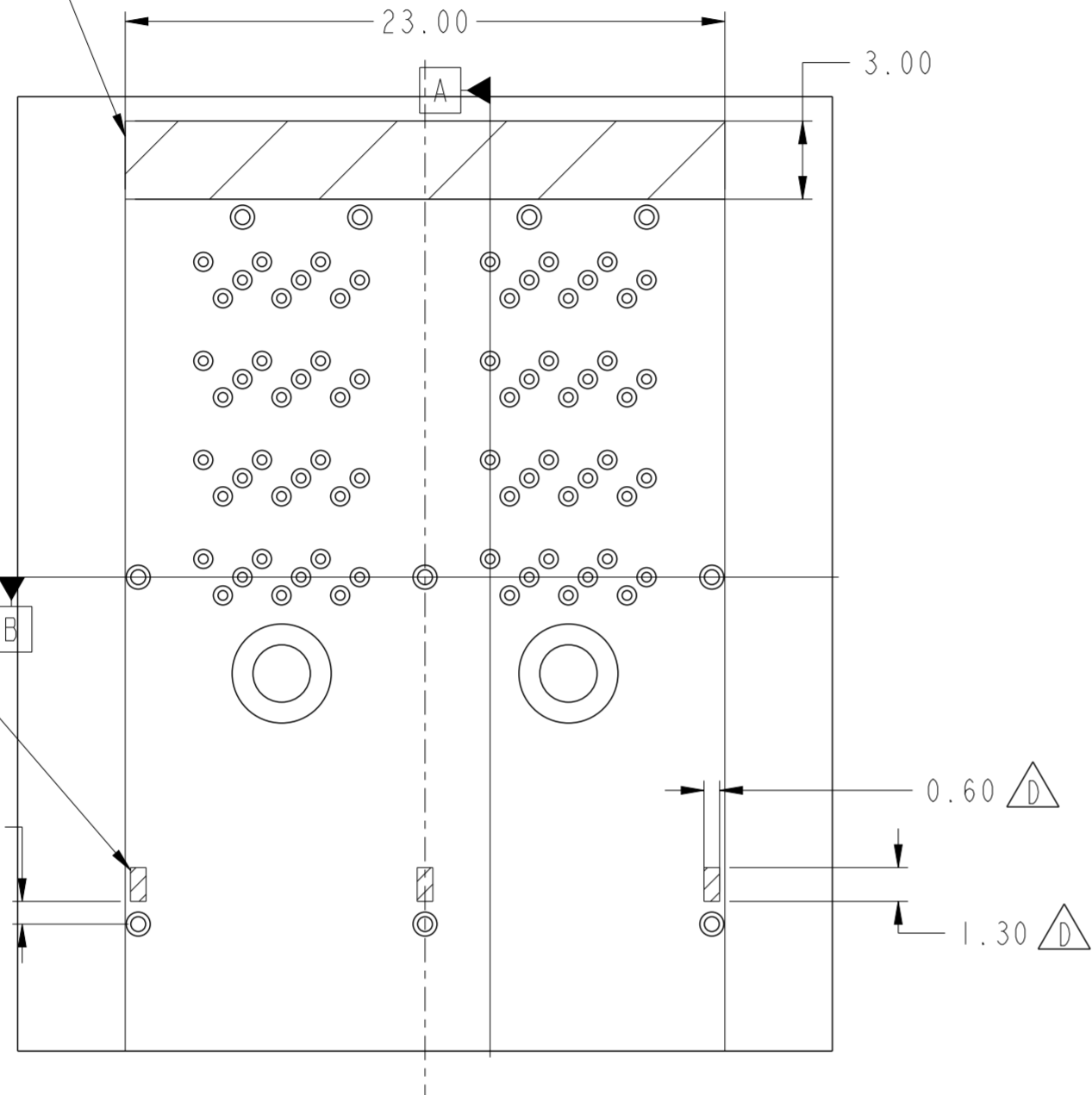

KEEP OUT AREA

0.87

0.60

1.30

RECOMMENDED EXTRACTION  
TOOL KEEP OUT AREA NO  
COMPONENTS IN THESE  
AREAS

18.00

2.50



Copyright FCI.

spec ref	-	dr	Mark Gray	2010/08/04	projection	MM	size	A2	scale	1:1
tolerance std	ASME Y14.5	eng	M Scholeno	2012/09/10	chr	-	ecn no	ELX-V-012260-1	rel level	Released
TOLERANCES UNLESS OTHERWISE SPECIFIED		appr	Brad Brubaker	2012/09/12	product family	MINI-SAS HD	rel level	Released		
surface	linear	0.X	±0.25	FCI	title	IX2 EXTERNAL ASSEMBLY	dwg no	10112627	rev	D
		0.XX	±0.13							
		0.XXX	±							
ASME Y14.5	angular	0°	±1/2°	www.fci.com	cat. no.	-	Product - Customer Drw	sheet 5 of 7		

PDS: Rev :D

STATUS:Released

Printed: Sep 13, 2012

# PIN OUT DESIGNATIONS

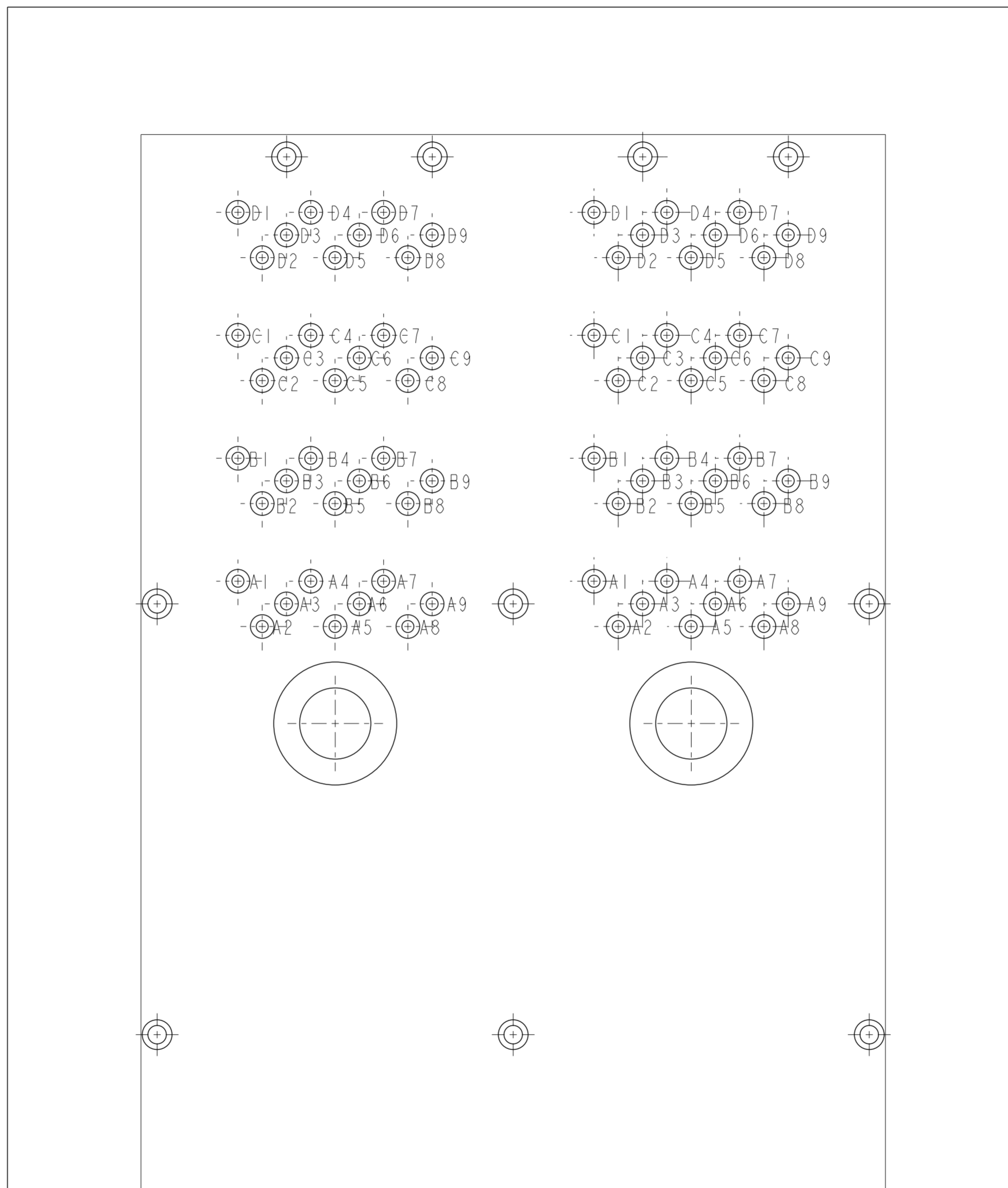

Copyright FCI.  
FCI

spec ref	-	dr	Mark Gray	2010/08/04	projection	MM	size	A2	scale	1:1
tolerance std	ASME Y14.5	eng	M Scholeno	2012/09/10			ecn no	ELX-V-012260-1		
	TOLERANCES UNLESS OTHERWISE SPECIFIED	chr	-	rel level				Released		
surface	✓	appr	Brad Brubaker	2012/09/12	product family	MINI-SAS HD	cat. no.	10112627	rev	D
ASME Y14.5	linear	0.X	±0.25	0.XX	±0.13	0.XXX	±	angular	0°	±1/2°
		www.fci.com		Product - Customer Drw		sheet 6 of 7				

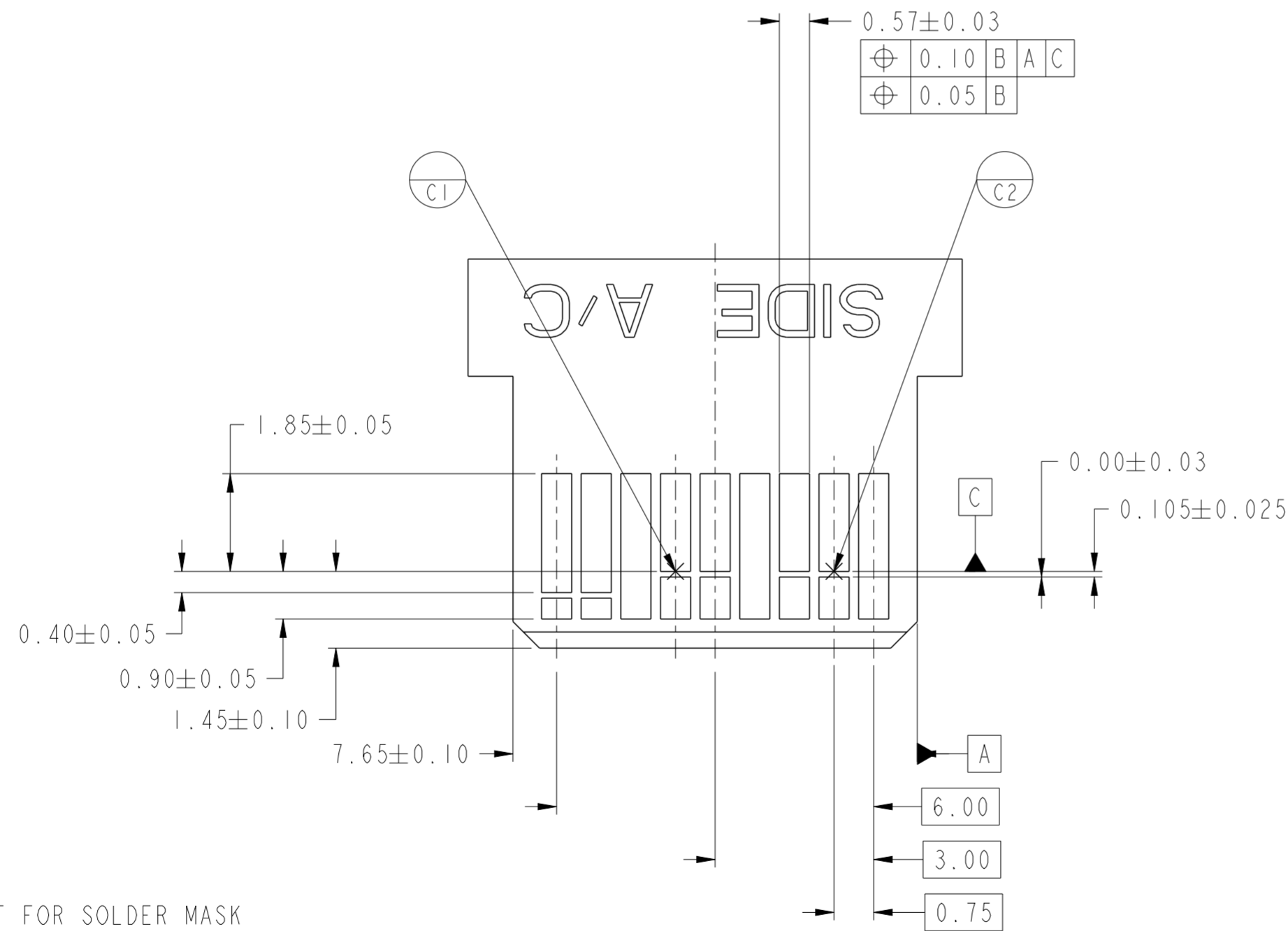
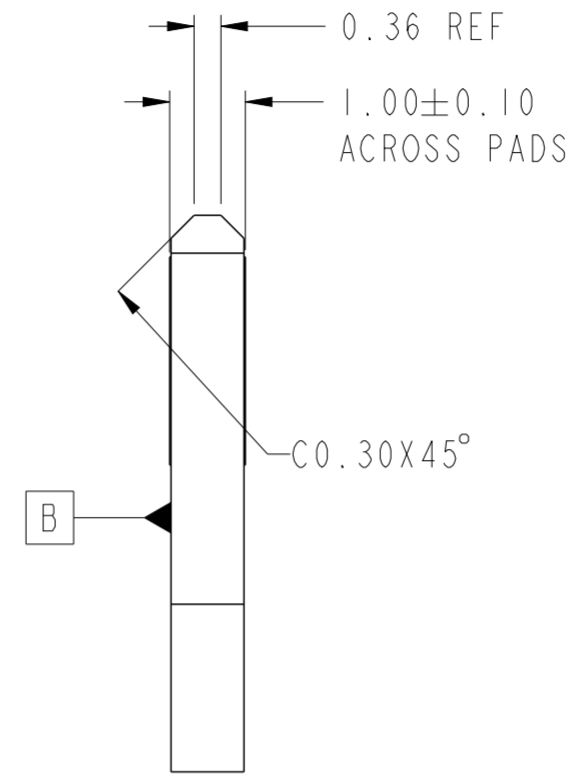
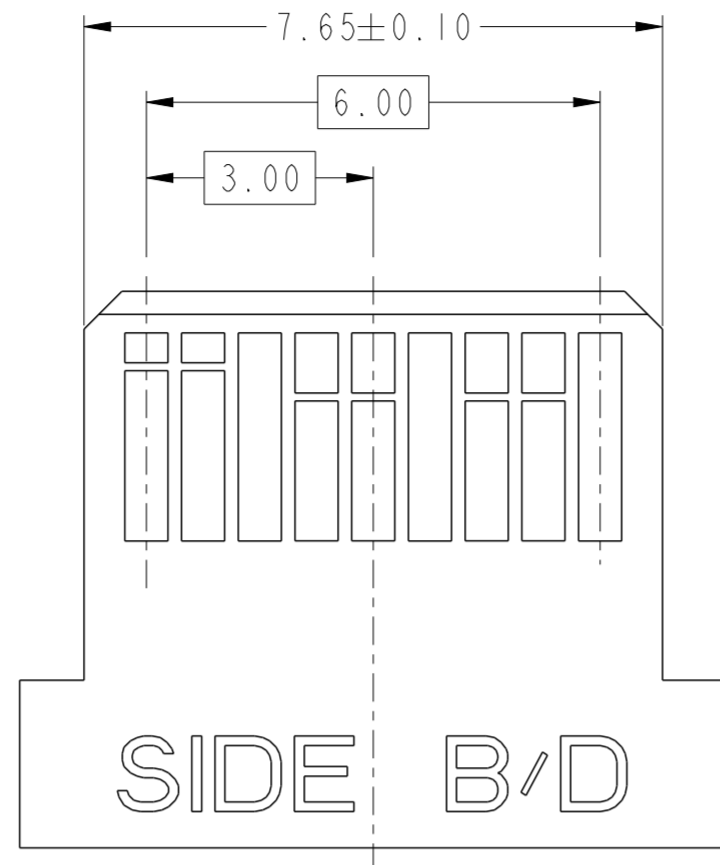

NOTES:

- 15. 0.05 MINIMUM KEEP OUT FOR SOLDER MASK AROUND ALL PADS.
- 16. DATUM D TARGETS ARE DEFINED BY THE RESPECTIVE PAD CENTER LINES AND THE LEADING EDGE OF THE TARGET PADS.

spec ref	-	dr	Mark Gray	2010/08/04	projection	MM	size	A2	scale	1:1
tolerance std	ASME Y14.5	eng	M Scholeno	2012/09/10	chr	-	ecn no	ELX-V-012260-1	rel level	Released
surface	✓	appr	Brad Brubaker	2012/09/12	product family	MINI-SAS HD	cat. no.	10112627	rev	D
ASME Y14.5	linear	0.X	±0.25	0.XX	±0.13	0.XXX	±-	angular	0°	±1/2°