

PART NUMBER	ENGINEERING NUMBER
1300680106	TC40140-200G

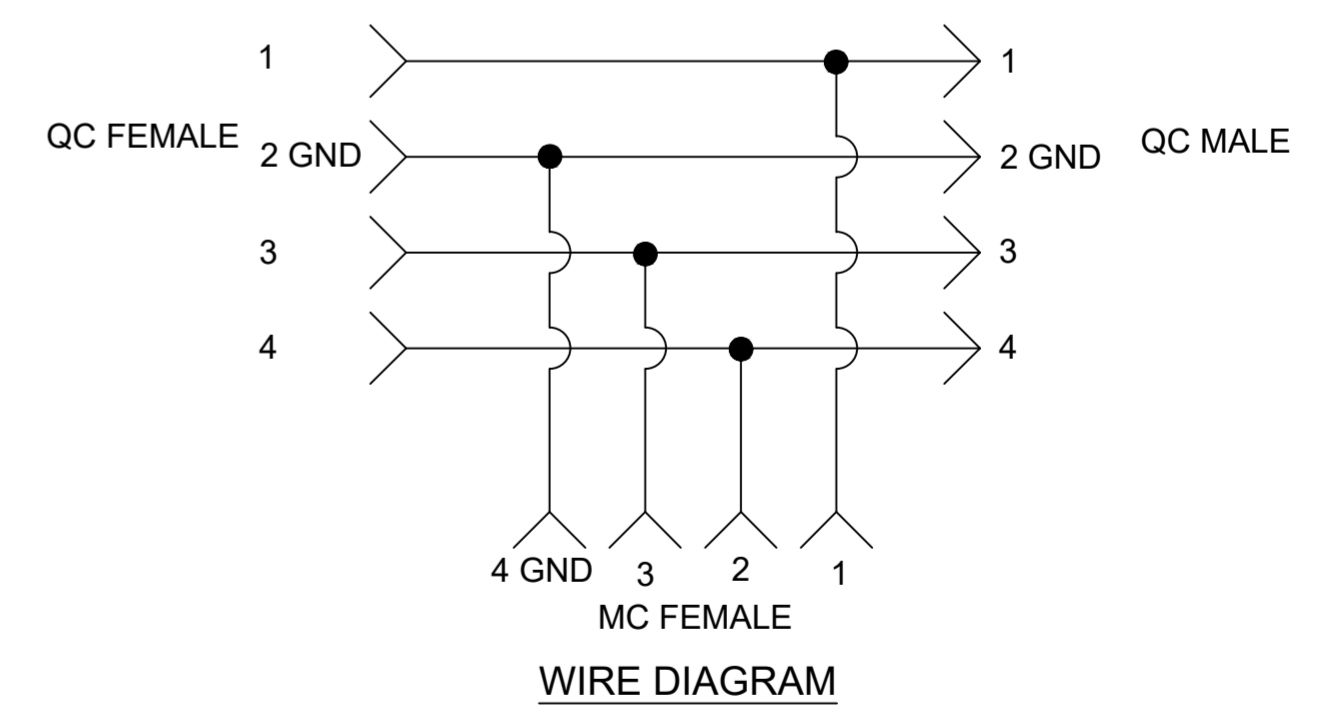
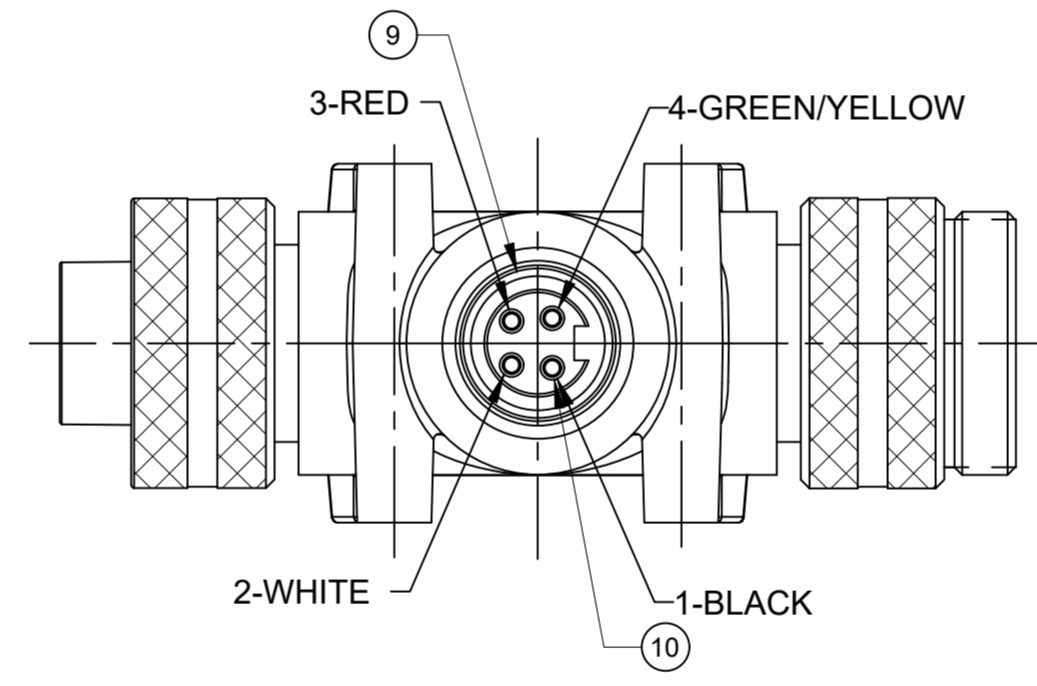
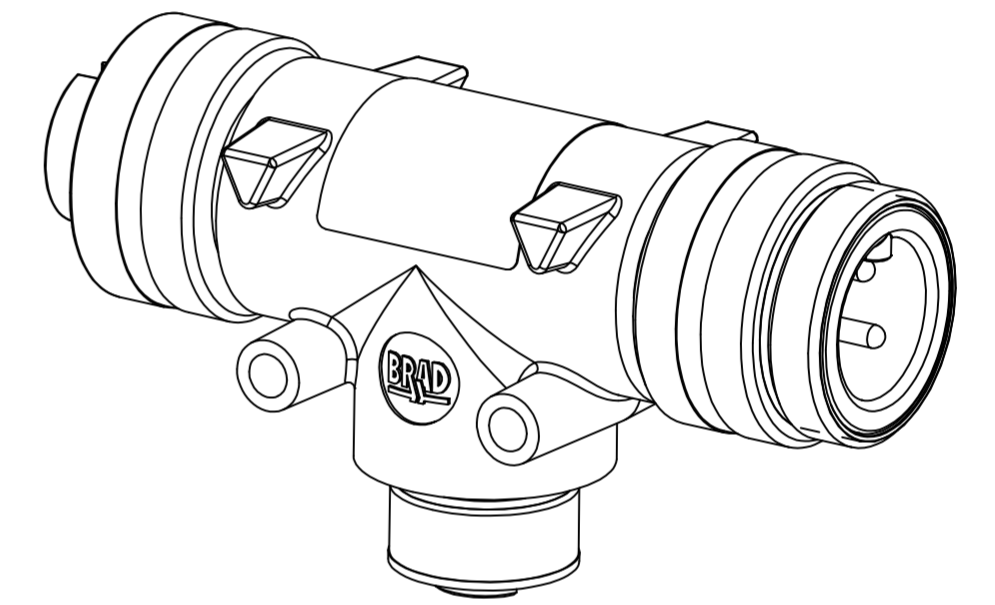
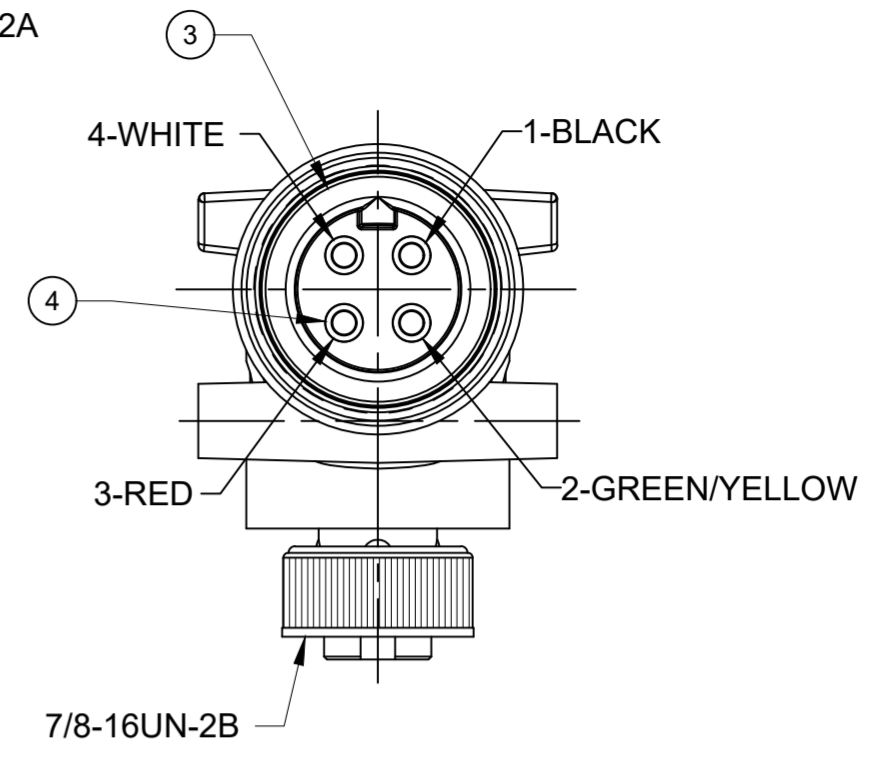
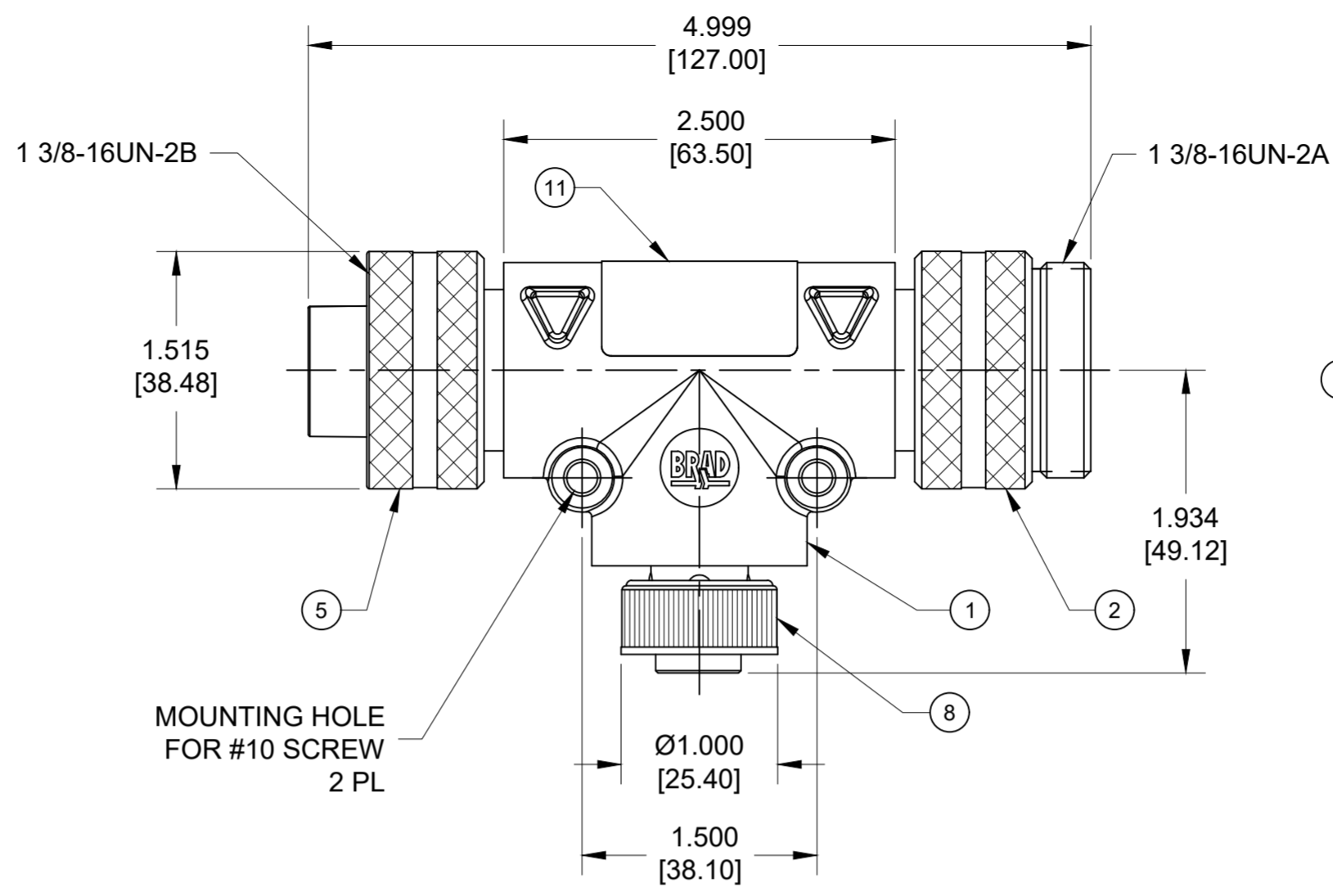
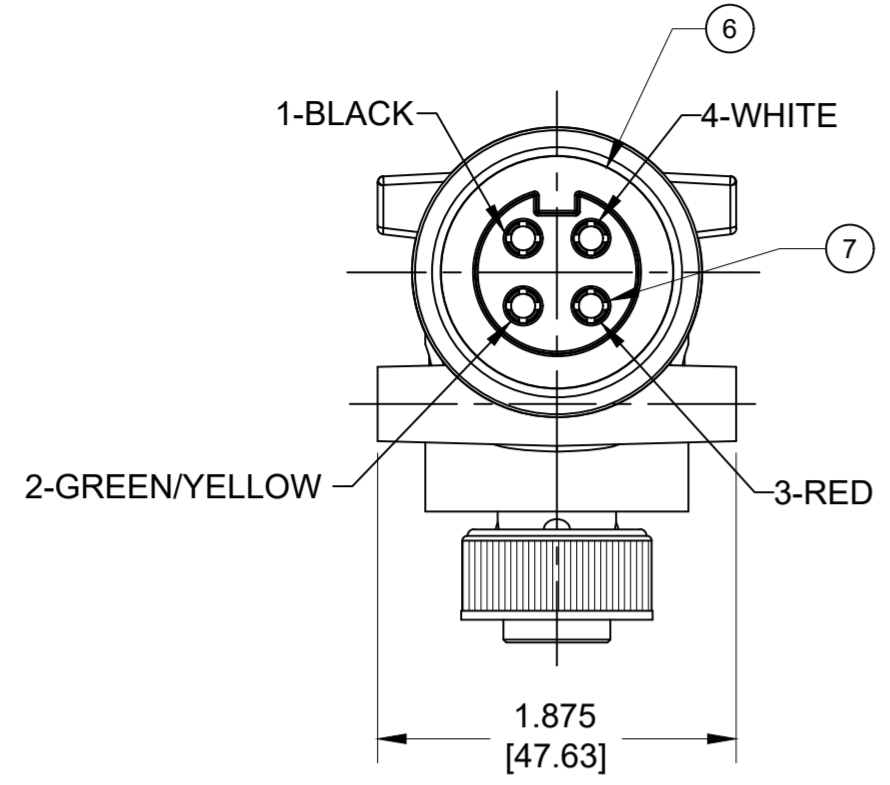

- NOTE:**
- MATERIAL: AS NOTED
  - FINISH: AS NOTED
  - ELECTRICAL DATA:  
VOLTAGE: 483V PER IEC60664 (B)  
600V PER UL2237  
MAX. THRU CURRENT: 32A (B)  
MAX. DROP CURRENT: 15A (B)
  - TEMPERATURE RANGE: -20°C TO +90°C
  - PROTECTION: IP67 (WHEN MATED)
  - UL LISTED FILE: E258922
  - PACKAGING:  
ASSEMBLIES ARE BAGGED SEPERATELY IN POLY BAGS WITH BAR CODE LABEL ATTACHED TO THE OUTSIDE OF THE BAG.
  - ASSEMBLY IS RoHS COMPLIANT
  - ALL DIMENSIONS ARE FOR REFERENCE UNLESS TOLERANCED OR NOTED OTHERWISE

11	1	LABEL	PLASTIC FILM	BLACK/YELLOW
10	4	MC SOCKET CONTACT	COPPER ALLOY	GOLD PLATED
9	1	MC FEMALE INSERT	TPE	BLACK
8	1	MC COUPLING NUT	ZINC ALLOY	BLACK E-COAT
7	4	QC SOCKET CONTACT	COPPER ALLOY	GOLD PLATED
6	1	QC FEMALE INSERT	TPE	BLACK
5	1	QC FEMALE COUPLING NUT	ALUMINUM	CLEAR ANODIZE
4	4	QC PIN CONTACT	COPPER ALLOY	GOLD PLATED
3	1	QC MALE INSERT	TPE	BLACK
2	1	QC MALE COUPLING NUT	ALUMINUM	CLEAR ANODIZE
1	1	OVERMOLD	TPE	BLACK
<b>ITEM</b>	<b>QTY.</b>	<b>DESCRIPTION</b>	<b>MATERIAL</b>	<b>FINISH</b>

(B)

THIS DRAWING CONTAINS INFORMATION THAT IS PROPRIETARY TO MOLEX ELECTRONIC TECHNOLOGIES, LLC AND SHOULD NOT BE USED WITHOUT WRITTEN PERMISSION

FUNCTIONAL SYMBOLS	DIMENSION UNITS	SCALE	CURRENT REV DESC: UPDATED MATERIALS, UPDATED AMPS, ADDED IEC VOLTAGE
FA=0	INCH/MM	NTS	
FC=0	GENERAL TOLERANCES (UNLESS SPECIFIED)		
FD=0			
DIVISIONAL SYMBOLS	mm	INCH	EC NO: 660415
	4 PLACES ±----	±----	DRWN: ABENJAMINLW 2021/01/21
	3 PLACES ±----	±0.005	CHK'D: ALEON01 2021/04/13
	2 PLACES ±0.13	±0.01	APPR: BWOODMAN 2021/05/05
	1 PLACE ±0.25	±0.02	INITIAL REVISION:
	0 PLACES ±----	±----	DRWN: CAAVILES 2014/10/30
	ANGULAR TOL ± 0.5 °		APPR: TWOLDEGE 2015/07/30
DRAFT WHERE APPLICABLE MUST REMAIN WITHIN DIMENSIONS	THIRD ANGLE PROJECTION	DRAWING	SERIES
		C-SIZE	130068

<b>molex</b>	
BRAD POWER	
QC 4 POLE TEE W/4 POLE MC DROP	
PRODUCT CUSTOMER DRAWING	
DOCUMENT NUMBER	DOC TYPE/DOC PART/REVISION
SD-130068-022	PSD 001 B
MATERIAL NUMBER	CUSTOMER
SEE CHART	GENERAL MARKET
SHEET NUMBER	
1 OF 1	