

REV. MARK	ECN NO.	日期 DATE	修改 DRAW	核准 APPROVE

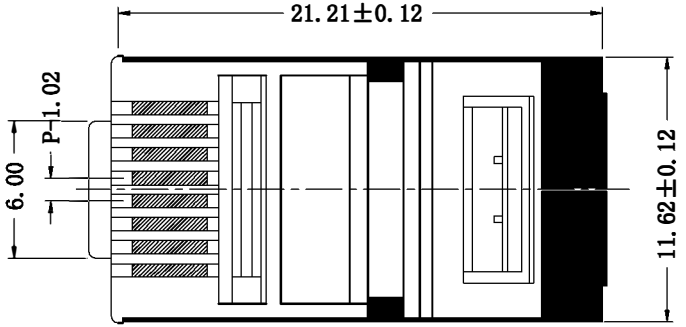

Note: steel thickness
0.2mm

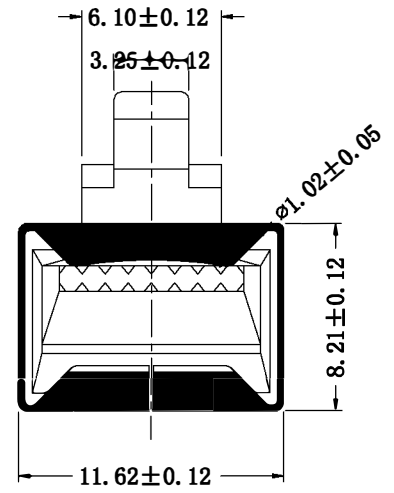
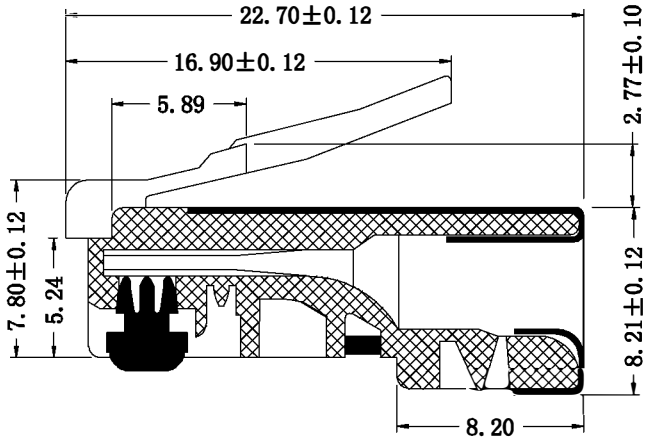
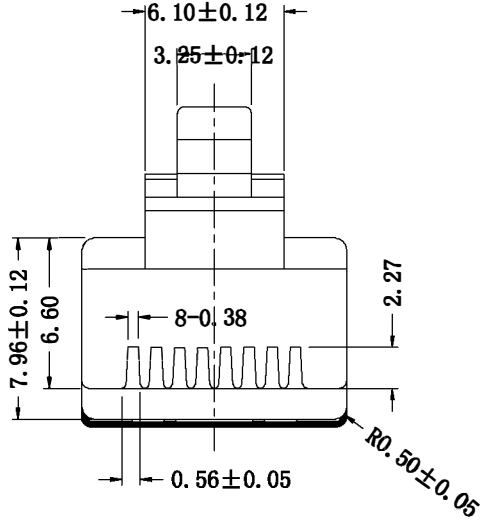
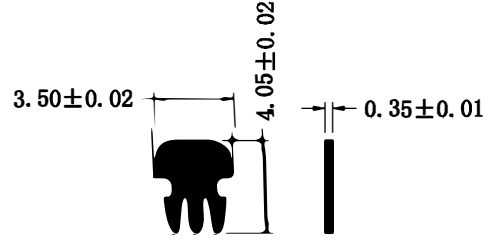

FEATURES:

- 1 Electrical Test:
 - A.250V AC max at 2 amps.
 - B.Dielectric with standing 500volts AC.
 - C.Insulation Resistance:500 megahms.
 - D.Termination Resistance:35megahms.
- 2 Mechanical:
 - A.Cable-to-Plug tensile strength-20LBs(89N)min.
 - B.Durability:500 mating cycles.
 - C. gold plating(口01, 口03, 口06, 口15, 口30, 口50)U*

REV. 版本	A/0	DATE 日期	UNITS 单位	MM	TITLE 产品名称	8P-8C(R) PLUG/屏蔽
DRAWN 绘图		2012. 07. 01	SCALE 比例	FULL	PART NO. 产品编号	RJ45-5F
APPROVED 审核		MATERIAL 材质	TOL. 公差	0.00 ±0.12	VIEW 视图	第三角法
FIREATING 防火等级	94V2	PC (聚碳酸酯)	EASE ELECTRONICS CO.,LIMITED			