

IR3 Single Gas Series Datasheet

Uncertified Infrared Single Gas Sensor (Portable and Fixed Systems)

The SGX infrared sensors use the proven Non-Dispersive Infrared (NDIR) principle to detect and monitor the presence of gases. With an infrared source and specific filtering on the pyroelectric detectors mounted inside the optical/gas cavity, individual gases or types of gas can be identified and their concentrations determined.

These sensors are suitable for reliable monitoring of gas levels in general applications that do not require a flameproof enclosure for hazardous environments.

The IR3 series range of infrared sensors are suitable for reliable monitoring of gas levels where the infrared sensor size is restricted. On their own, these sensors cannot be placed in hazardous areas, but they are suitable for installation in instrumentation that is hazard certified.

The IR3 series range has been designed for installation into certified housings, monitoring of CO2 in hyperbaric applications (e.g. diving) where high pressures can exist or applications where the accuracy is not too important (e.g. school science projects) where the sensor zero can be set before use.

APPLICATIONS

- Oil & Gas*
 - Petrochemical*
 - Steelworks*
 - Wastewater
 - School Science Equipment
 - Confined Space Entry
 - Indoor Air Quality
 - SCUBA Diving Equipment
- * When built into certified housing

FEATURES

- For detection of the following gases:
 - Carbon Dioxide (IR31 Series),
 - Hydrocarbons (IR32 series, IR33 series)
- Gas concentration ranges:
 - 0 - 5% Carbon Dioxide (also suitable for 0 to 0.5%v/v)
 - 0 - 100%v/v Hydrocarbons (also suitable for 0 to 100%LEL)
- 19.0mm sensor height
- Low power
- Reference channel for self-compensation on most types
- Special gold plated optical gas cavity for stable signal levels
- Operational in varying temperature, pressure and humidity
- Fast response
- Rugged stainless steel construction
- No moving parts
- Immunity from 'poisoning'
- Reliable fail-safe operation



OPERATION

To operate, the sensors must be interfaced to a suitable circuit for power supply, output amplification and signal processing. Sensor outputs require linearisation and compensation for ambient temperature variation using algorithms in the system firmware. This is necessary for sensors to meet their full performance specification. An external temperature sensor will be required for temperature compensation. Further compensation for pressure changes can also be made in an algorithm, provided there is a suitable input from a pressure sensor.

A set of Application Notes is available from the SGX Sensortech Ltd website, to explain more about NDIR gas sensing and provide advice for the end-user on interfacing the sensors and processing signals.

TECHNICAL SPECIFICATION

Mechanical

Dimensions	See Outline
Body material	Stainless Steel
Approximate Weight	27g

Environmental

Ambient temperature range for operation: storage:	-20°C to +55°C -20°C to +55°C
Operational pressure range	30kPa to 130kPa (2000 kPa for IR31CE)
Humidity range for operation and storage	0 to 95% RH (Non-condensing)

Electrical

DC supply to detectors	3V to 5V
Typical power	180mW @ 5V
IR Source Supply (Recommended)	+5V, 60mA (Square Wave at 4Hz, 50% duty cycle)

Whilst SGX has taken care to ensure the accuracy of the information contained herein it accepts no responsibility for the consequences of any use thereof and also reserves the right to change the specification of goods without notice. SGX accepts no liability beyond the set out in its standard conditions of sale in respect of infringement of third party patents arising from the use of SGX products in accordance with information contained herein. In case of modification of the product, SGX disclaims all liability.

CONFIGURATIONS

Sensor Type	Gas	Concentration Range *		Mesh		Application(s)	
		Highest	Lowest	Yes	No		
IR31BC	Carbon Dioxide	0 to 5%	0 to 0.5%		✓	Oil & Gas Petrochemical Steelworks Wastewater School Science Equipment Confined Space Entry Indoor Air Quality	
IR31CE				✓			SCUBA Diving Equipment
IR31SE				✓			School Science Equipment
IR32BC	Methane / Hydrocarbons	0 to 100%	0 to 100%LEL		✓	Oil & Gas Petrochemical Steelworks Wastewater	
IR33BC					✓		

* The Highest Concentration Range is the highest range the sensor is suitable. The Lowest Concentration Range is the lowest range the sensor is suitable. The use of the sensor beyond these ranges will affect the sensor's performance.

IR31BC

The sensor has been designed for monitoring carbon dioxide up to 5%/v. The sensor contains a reference channel for self-compensation, including degradation of the lamp and temperature compensation to some extent, although additional temperature compensation will still be required. The sensor has been design to, but not limited to, being built into a certified housing for use in explosive atmospheres.

The open front (no mesh) of the sensor must be closed with a suitable gas diffusion membrane, e.g. stainless steel sintered disc or mesh. As well as preventing entry of dust and contamination, the membrane also acts as a partial reflector for infrared. This will cause a slight increase in the pyroelectric detector output voltages. It is important that the gas diffusion membrane be securely attached and rigid enough not to cause flexing and spurious signal instability during ambient temperature and pressure changes.

IR31CE

The sensor has been designed for monitoring carbon dioxide in hyperbaric applications where the operating pressure can be as high as 2000 kPa. Compensation for changes in pressure will be required using the signal from a suitable pressure sensor. The sensor contains a reference channel for self-compensation, including degradation of the lamp and temperature compensation to some extent, although additional temperature compensation will still be required. The sensor contains a mesh so does not need to be placed behind any other sinter or mesh and uses a reference detector which does not become responsive to carbon dioxide under high pressures which occurs with other infrared carbon dioxide sensors due to the effective broadening of the filter at the high pressures. The IR31CE must not be used for monitoring CO2 in mixtures including hydrocarbon gases or vapours.

IR31SE

The IR31SE is an economy sensor designed for applications where the accuracy is not too important and can be zeroed before use (e.g. school science project equipment). The sensor does not contain a reference detector for self-compensation, including degradation of the lamp and temperature compensation. The sensor does contain a mesh so does not need to be placed behind any other sinter or mesh.

IR32BC

The sensor is of the same construction as the IR31BC, except designed to monitor hydrocarbons up to 100%/v but is also suitable for monitoring %LEL levels. The sensor cannot be used to monitor benzene.

IR33BC

The sensor is of the same construction as the IR31BC, except designed to monitor hydrocarbons up to 100%/v but is also suitable for monitoring %LEL levels. When compared with the IR32BC the sensor has slightly higher response to humidity but lower cross sensitivity to other hydrocarbons when compared to methane. The sensor can also be used to detect benzene.

HANDLING PRECAUTIONS

1. Do not allow sensors to fall on the floor. This could cause IR Source filament breakage, damage to the pins and the gas entrance aperture.
2. Do not apply mechanical force against the gas entrance aperture.
3. Do not immerse sensors in water or other fluids.
4. Protect the gas entrance aperture against dust ingress and sprayed materials.
5. Anti-static handling precautions must be taken.

PERFORMANCE

For test purposes, all data taken using the following conditions:

- Performance as tested in the SGX IR-EK2 Evaluation Kit directly after calibration.
- SGX linearisation and temperature compensation algorithms applied; see Infrared Sensor Application Notes.
- IR Source Voltage 5V, square wave, at 4 Hz and 50% duty cycle. Running the IR Source at 3V will decrease performance due to lower output signals.
- Ambient temperature (20°C) and pressure (101 kPa).
- All gases diluted in dry nitrogen.
- Performance for the Hydrocarbons refers to Methane only. Most other hydrocarbons will have an improved performance.
- Refer to Application Notes for more information.

Sensor type	IR31BC	IR31CE	IR31SE	IR32BC	IR33BC
Gas	Carbon Dioxide			Methane / Hydrocarbons ⁽⁵⁾	
Concentration Range	Refer to Configurations Table				
Warm-up Times	<20 sec to operate <60 sec for Zero \pm 1% of Full Scale, <30 min to full specification at 20 °C				
Maximum Response Time (T ₉₀) ⁽¹⁾	20 sec				
Peak-to-Peak Outputs (in N ₂) ⁽²⁾ Active (mV): Reference (mV):	6 to 19 10 to 30	8 to 18 10 to 30	12 to 28 -----	8 to 30 10 to 30	13 to 40 10 to 30
Sensitivity to Standard Test Gas ^{(2) (3)} Minimum Absorbance: Maximum Absorbance:	0.25 0.60	0.25 0.60	0.10 0.25	0.07 0.15	0.07 0.15
Typical Sensitivity for Gas Range ⁽³⁾	Refer to Fractional Absorbance Curves				
Minimum Detection Level ⁽⁴⁾	2ppm CO ₂	2ppm CO ₂	5ppm CO ₂	50ppm CH ₄	30ppm CH ₄
Maximum deviation from linearity (\pm) ⁽⁶⁾ 0 to 0.5%v/v Range: 0 to 2%v/v Range: 0 to 2.5%v/v Range: 0 to 5%v/v Range: 0 to 10%v/v Range: 0 to 100%v/v Range:	0.01%v/v 0.05%v/v ----- 0.10%v/v ----- -----	0.01%v/v 0.05%v/v ----- 0.10%v/v ----- -----	0.02%v/v 0.08%v/v ----- 0.15%v/v ----- -----	----- ----- ----- 0.15%v/v ----- 5%v/v	----- ----- ----- 0.15%v/v ----- 5%v/v
Temperature Variation (\pm ppm/°C) ⁽⁷⁾ Zero and Concentration Range Maximum (-20°C to +55°C) Zero: 0.5%v/v: 2%v/v: 2.5%v/v: 5%v/v: 10%v/v: 100%v/v:	10 25 100 ----- 250 ----- -----	10 25 100 ----- 250 ----- -----	15 35 150 ----- 350 ----- -----	25 ----- ----- ----- 200 ----- 2000	20 ----- ----- ----- 150 ----- 1500

Sensor type	IR31BC	IR31CE	IR31SE	IR32BC	IR33BC
Short Term Stability (\pm)⁽⁸⁾: Zero: 0.5%v/v: 2%v/v: 2.5%v/v: 5%v/v: 10%v/v: 100%v/v:	5 ppm 0.01%v/v 0.05%v/v ----- 0.10%v/v ----- -----	5 ppm 0.01%v/v 0.05%v/v ----- 0.10%v/v ----- -----	8 ppm 0.02%v/v 0.08%v/v ----- 0.15%v/v ----- -----	0.01%v/v ----- ----- ----- 0.08%v/v ----- 2%v/v	0.01%v/v ----- ----- ----- 0.08%v/v ----- 2%v/v
Humidity Response (+)⁽⁹⁾ Zero: 0.5%v/v: 2%v/v: 2.5%v/v: 5%v/v: 10%v/v: 100%v/v:	Negligible			0.10%v/v ----- ----- ----- 0.25%v/v ----- 2%v/v	0.15%v/v ----- ----- ----- 0.30%v/v ----- 2%v/v
Pressure Effects⁽¹⁰⁾	Sensors shall meet specification within a \pm 5% change in ambient pressure from the ambient pressure during calibration				
MTBF (IR Source only)	>10 years for 5 V operation, >20 years for 3 V operation				
Vibration	Conforms to EN 60079-29-1				
Ingress Protection	Requires extra protection depending on application				

- (1) Based upon an immediate step change in concentration at the aperture of the sensor.
- (2) Production Test Limits, using standard test gases of Dry Nitrogen, 2%v/v Carbon Dioxide and 5%v/v Methane, where appropriate.
- (3) A 0.30 absorbance is equivalent to a 30% decrease in the Active peak-to-peak output.
- (4) The minimum detection level is the smallest detectable change in concentration based upon a 2 sigma variation. The best detectable change occurs at 0% gas concentration due to the non-linear output of the detector (see Fractional Absorbance Curves).
- (5) Performance for most hydrocarbons will be better than for methane for equivalent concentrations, as methane is one of the lower sensitive gases compared to other hydrocarbons.
- (6) After linearisation using the recommended method of linearisation and based upon a calibration gas with a concentration >75% of the full-scale.
- (7) Using average Alpha and Beta coefficients based upon test data from the instrument in which the sensor is being tested. Refer to Application Notes for information on calculating Alpha and Beta coefficients. Accuracy can be improved by measuring each sensor over temperature to define specific Alpha or Alpha & Beta coefficients.
- (8) After sensor stabilisation and over a period of 8 hours.
- (9) Difference in response when changed from 0 %RH to 90 %RH.
- (10) Sensors can be used over a greater ambient pressure using pressure compensation of the concentration. An external pressure sensor will be required for this.

FRACTIONAL ABSORBANCE CURVES

These show the typical sensitivity versus concentration before linearisation for the range of gases. For further explanation, refer to the Infrared Sensor Application Notes.

Primary Target Gases

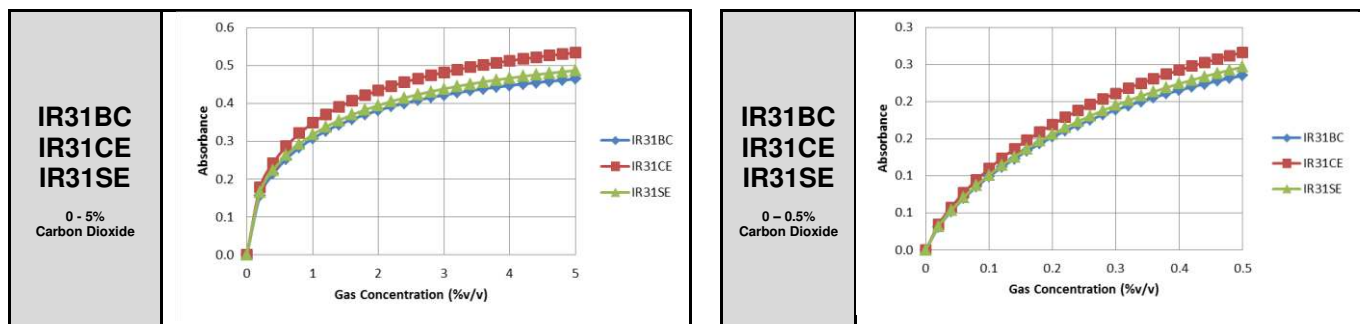

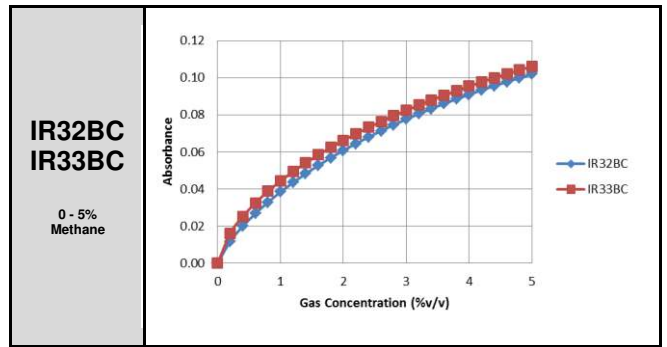
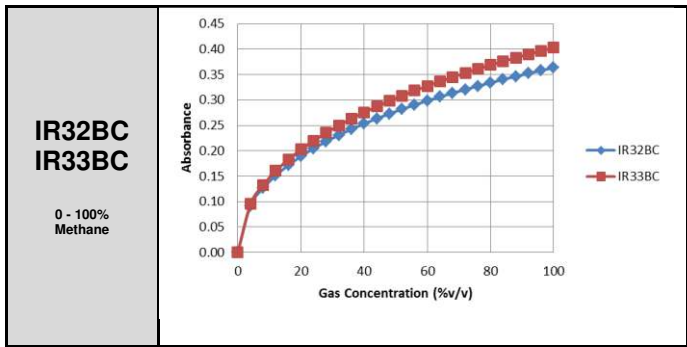

CERTIFICATIONS

The IR3xxx series gas sensors are not classified as certified devices in hazardous areas. However, they may be used in hazardous areas provided that they are installed in a suitable housing complete with flame arrestor. The housing must also protect the sensor from contamination and mechanical impacts. For SGX sensors usable on their own in hazardous areas, refer to the IR1, IR2 or IR600 Series gas sensor datasheets for single gas monitoring and the IR15 or IR25 series gas sensor datasheets for dual gas monitoring.

OUTLINE

(All dimensions in millimetres; dimensions without limits are nominal)

With Mesh (See Configuration Table)

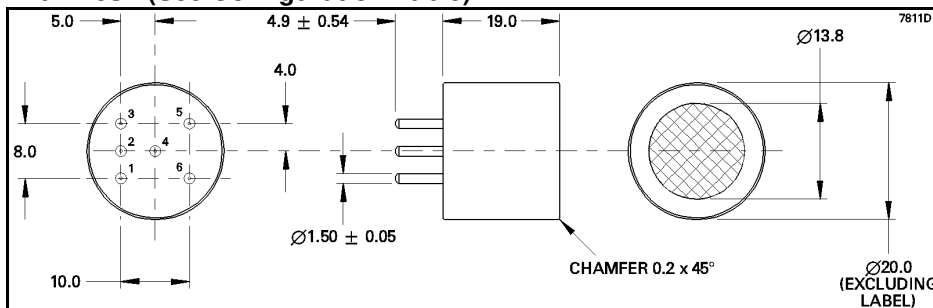

Without Mesh (See Configuration Table)

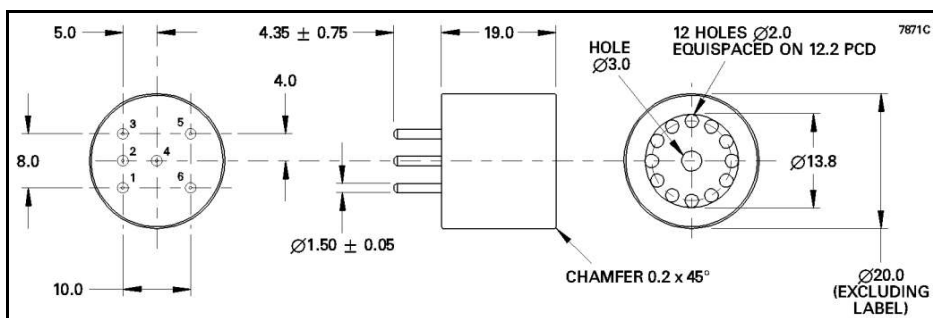

Connections

Pin	Connection
1	+V DC detector input
2	IR Source
3	IR Source return
4	Active detector output
5	Reference detector output (not available on IR31SE)
6	0 V input

Outline Notes

1. Body dimensional tolerances ± 0.1 mm. Pin dimensional tolerances as indicated.
2. IR3xxx Series sensors are designed to press-fit into PCB sockets. The end-user should choose a socket to accommodate the full sensor pin length. This will ensure a stable mechanical location as well as good electrical contact. SGX Sensortech Ltd recommend the Wearn's Cambion type 450-1813-01-03-00 single-pole solder mount socket with through hole, or a suitable equivalent.

ACCESSORIES

Dust Membrane (DPP702964BA)

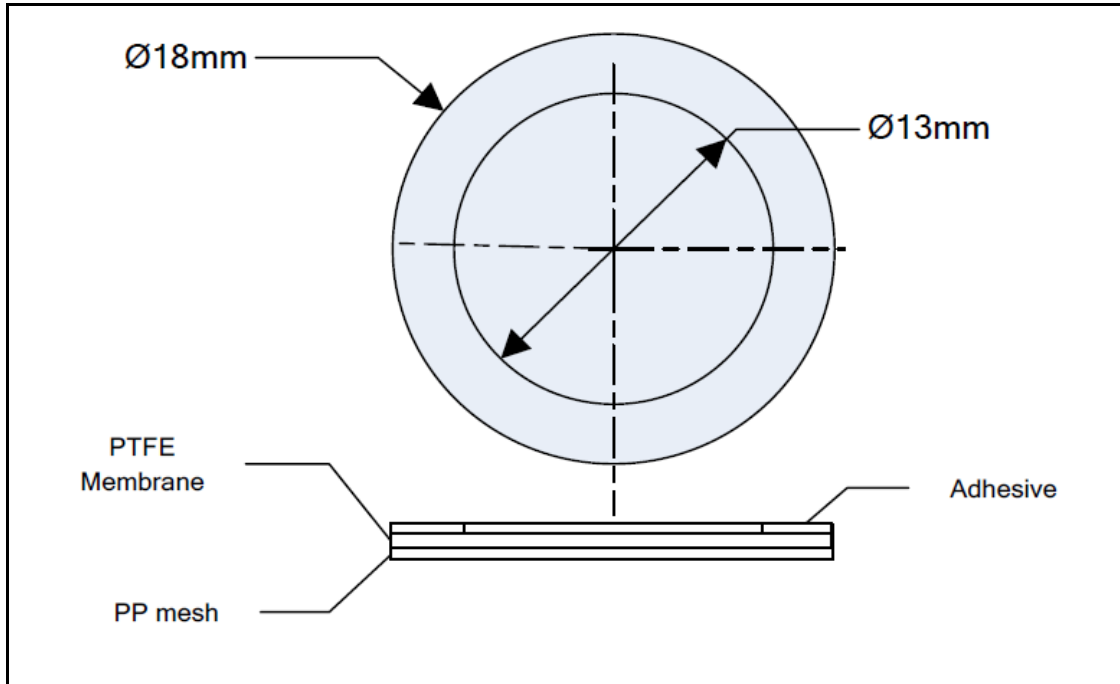

Material	PTFE
Air Flow	$\geq 6.8 \text{ l/hr/cm}^2$ (Δp 10mbar)
Water Intrusion Pressure	$\geq 210 \text{ mbar}$
Laminated PTFE Thickness	0.28 mm (nominal)
Adhesive Thickness	0.19 mm (nominal)
Typical Pore Size	5 μm