

PART NUMBER	REV	FIRST USED	POWER UNIT	FEED TYPE	DESCRIPTION
1855494-1	A	122500-1	LEADMAKER	AIR FEED	CUTS CARRIER
1855494-2	A	565435-5	BENCH MODEL K	AIR FEED	CUTS CARRIER
1855494-3	A	354500-1	BENCH MODEL G	AIR FEED	CUTS CARRIER
7-1855494-7	A	-	-	-	SPARE PARTS

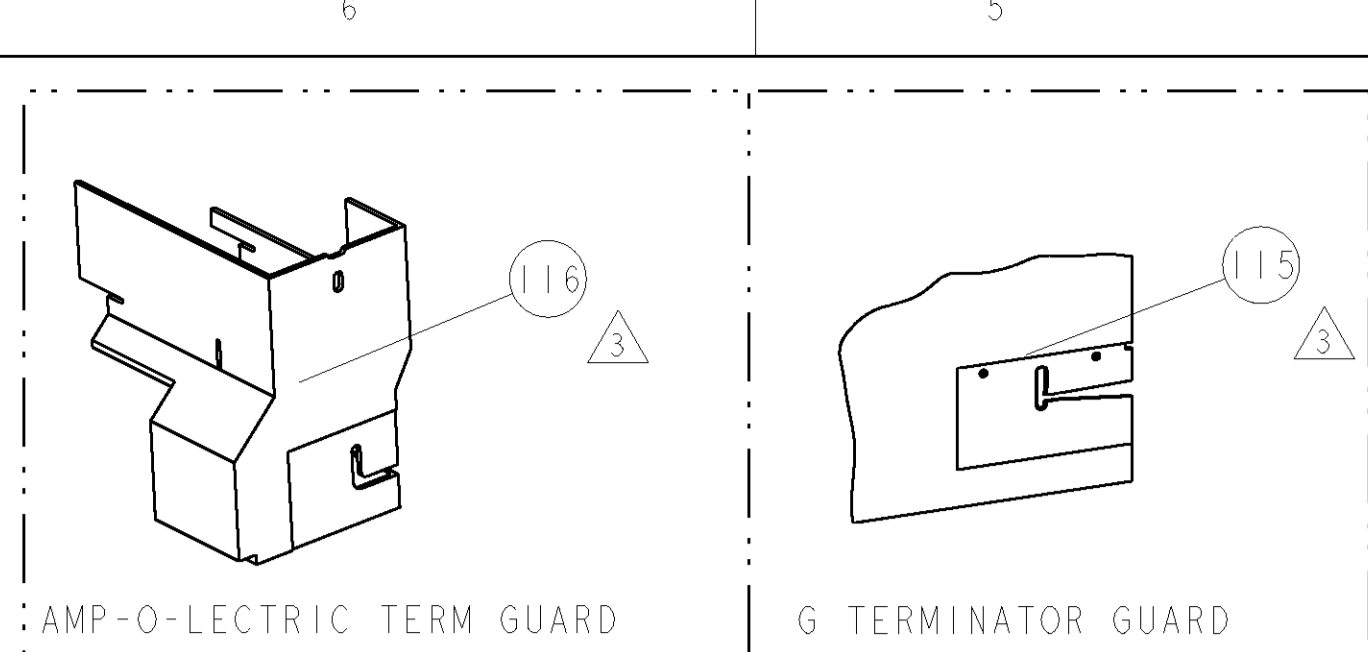

TERMINAL NAME: MINI VARILOK CONTACT		ELCO CORP. TERMINAL - TE CRIMP SPECS		REF SETTING	
TE PN	ELCO CORP.				
1949932	60-8216-0323-00-343				
		CRIMP HEIGHT	WIRE SIZE	REF SETTING	
-	-	.040±.002/-0.002 [1.02mm±.05/-0.05]	22AWG	B7	
-	-	.037±.002/-0.002 [.94mm±.05/-0.05]	24AWG	C2	
-	-	.036±.002/-0.002 [.91mm±.05/-0.05]	26AWG	C3	
-	-	.035±.002/-0.002 [.89mm±.05/-0.05]	28AWG	C4	
		CRIMP	SIZE	TYPE	RANGE
-	-	-	.062 [1.57mm]	F	30-22 AWG
-	-	-	.075 [1.91mm]	O	∅ .065 MAX
WIRE STRIP LENGTH	TERM APPL SPEC	FEED	APPLICATOR INSTRUCTIONS	SET UP GAGE	
.11-.14	TE	.25	408-8040	458637-1	

LOC	DIST	REVISIONS				
A	66	P LTR	DESCRIPTION	DATE	DWN	APVD
		A	RELEASED	06MAR2009	BH	BH

- △ RECOMMENDED SPARE PARTS
- △ GREASE LIGHTLY
- △ GUARD MUST BE IN PLACE WHEN OPERATING APPLICATOR IN A BENCH MACHINE
- △ INSTALL ITEMS 101, 102 & 119 ON SIDE OF STRIPPER ON APPLICATOR USING ITEM 21.
- △ CUT TO LENGTH AT ASSEMBLY.

ADDITIONAL CRIMP HEIGHTS		
CRIMP HEIGHT	WIRE SIZE	REF SETTING
.034±.002 [.86±0.05mm]	30AWG	C6

**\* WARNING**  
ON INSTALLATION, SET WIRE DISC TO LARGEST WIRE SIZE SETTING. USE OF SETTINGS BELOW MIN. REQUIRED CRIMP HEIGHT SETTING WILL CAUSE DAMAGE TO CRIMP TOOLING.

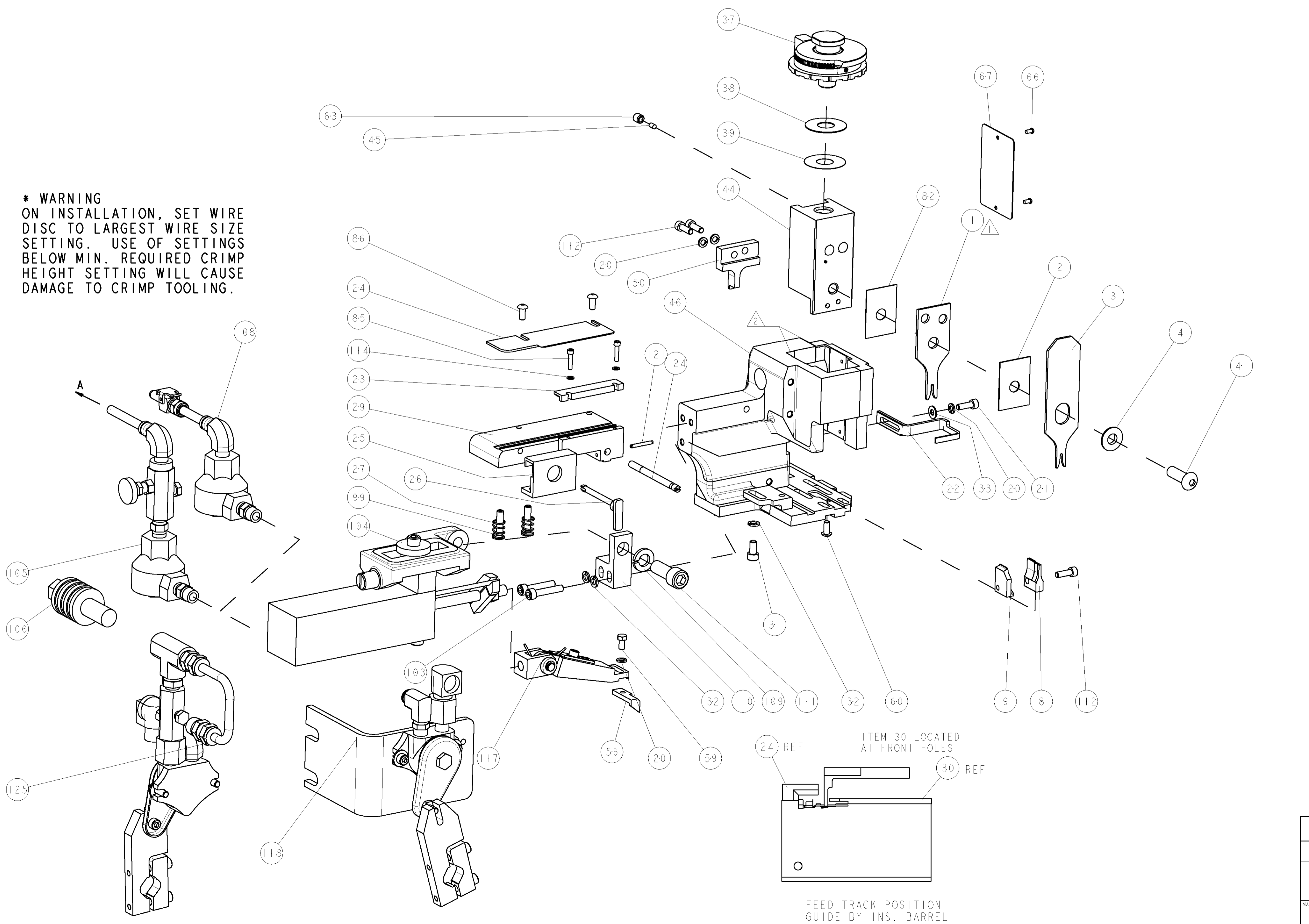

-	-	1	-	-	455350-4	AIR BLAST ASS'Y	125
-	-	1	1	1	690432-6	ADJUSTMENT SCREW	124
-	-	1	1	1	4-21028-0	PIN, SLOTTED SPRING .094 X .750	121
-	-	1	1	AR	27319-4	TUBING 1/4" O.D.	119
-	-	1	-	-	692655-6	AIR FEED VALVE ASSEMBLY	118
-	-	1	1	1	461062-1	FEED FINGER ASSEMBLY	117
-	-	REF	-	-	455749-1	GUARD WINDOW	116
-	-	REF	-	-	679532-1	INSERT, GUARD	115
-	2	2	2	-	21024-2	WASHER, SPRG LOCK, REG NO 4	114
-	2	2	2	-	2-21000-7	SCR, SKT HD CAP 8-32 X .500	112
-	1	1	1	-	3-21001-5	SCR, SKT HD CAP 3/8-16 X 1.000	111
-	1	1	1	-	459610-1	MOUNT, FEED BRACKET	110
-	1	1	1	-	21024-8	WASHER, SPRG LOCK, REG 3/8	109
-	1	-	1	-	692655-7	AIR FEED VALVE ASSEMBLY	108
-	-	1	-	-	24042-2	VALVE, SLEEVE, 3-WAY	106
-	-	1	-	-	692655-5	AIR FEED VALVE ASSEMBLY	105
-	1	1	1	-	461065-2	ASSEMBLY, AIR FEED	104
-	2	2	2	-	3-21000-9	SCR, SKT HD CAP 10-32 X 1.000	103
-	-	1	-	-	986220-3	CLAMP, CABLE, BLACK	102
-	-	1	-	-	23238-1	INSERT, COUPLING	101
-	2	2	2	-	5-21006-6	SCR, SET, CUP POINT 10-32 X .750	99
-	1	1	1	-	2-21000-7	SCR, SKT HD CAP 8-32 X .500	88
-	2	2	2	-	2-21002-1	SCR, BTN SKT HD CAP 8-32 X .375	86
-	2	2	2	-	1-21000-5	SCR, SKT HD CAP 4-40 X .500	85
-	1	1	1	-	455888-4	SPACER, CRIMPER	82
-	1	1	1	-	4088040	SF APPL INST 408-8040	72
-	1	1	1	-	217238-1	GENERAL INSTRUCTION PKG	71
-	1	1	1	-	461264-5	PLATE, IDENTIFICATION	67
-	2	2	2	-	21017-2	SCREW, DRIVE	66
-	1	1	1	-	21009-2	SCR, SET, SELF LOCKING 1/4-20 X .250	63
-	1	1	1	-	22733-8	SCR, BHSC, SELF-LOCKING, 8-32 X .375	60
-	1	1	1	-	2-22603-0	SCREW, MACH, HEX HD, 8-32 X .312	59
-	1	1	1	-	694433-8	FEED PAWL	56
-	1	1	1	-	1490894-4	SLUG BLADE	50
-	1	1	1	-	1633399-1	APPL., BASIC AIR FEED SUB ASSY	46
-	1	1	1	-	690191-1	PLUG, NYLON	45
-	1	1	1	-	455673-1	RAM, SIDE FEED	44
-	1	1	1	-	7-21002-9	SCR, BTN SKT HD CAP 5/16-24 X 1.00	41
-	1	1	1	-	690125-1	SHIM SUB-ASSY	39
-	1	1	1	-	1-469367-2	SHIM	38
-	1	1	1	-	879103-3	FINE ADJUST HEAD ASSEMBLY	37
-	1	1	1	-	21055-6	WASHER, FLAT, REG NO 8	33
-	3	3	3	-	21024-5	WASHER, SPRG LOCK, REG NO 10	32
-	1	1	1	-	3-21000-4	SCR, SKT HD CAP 10-32 X .375	31
-	1	1	1	-	5-455671-7	PLATE, STRIP GUIDE	29
-	2	2	2	-	1-22282-1	SPRING, COMPRESSION	27
-	1	1	1	-	690546-1	LEVER, DRAG RELEASE	26
-	1	1	1	-	1-690754-6	DRAG, SPECIAL	25
-	1	1	1	-	8-690440-6	GUIDE, REAR STRIP	24
-	1	1	1	-	2-690712-8	FRONT STRIP GUIDE	23
-	1	1	1	-	1-458230-5	STRIPPER	22
-	1	1	1	-	2-21000-7	SCR, SKT HD CAP 8-32 X .500	21
-	4	4	4	-	21024-4	WASHER, SPRG LOCK, REG NO 8	20
-	-	-	-	-	-	-	13
-	-	-	-	-	-	-	12
-	-	-	-	-	-	-	11
-	-	-	-	-	-	-	10
-	1	1	1	-	4-853714-5	PLATE, REAR SHEAR	9
-	1	1	1	-	1633780-1	ANVIL, SPECIAL, COMBINATION	8
-	-	-	-	-	-	-	7
-	-	-	-	-	-	-	6
-	-	-	-	-	-	-	5
-	1	1	1	-	1-238009-7	BLOCK, FL CRIMPER SPACER	4
-	1	1	1	-	6-1583690-5	CRIMPER, INSUL O	3
-	1	1	1	-	455888-6	SPACER, CRIMPER	2
-	1	1	1	-	4-456403-2	CRIMPER, WIRE PREMIUM	1

DIMENSIONS:		TOLERANCES UNLESS OTHERWISE SPECIFIED:		DWN		Tyco Electronics	
INCHES	0 PLC ±.01	1 PLC ±.01	2 PLC ±.01	3 PLC ±.001	4 PLC ±.0001	APVD	NAME
	ANGLES ±.0001					W. DEMING	18MAR2009
MATERIAL	FINISH	WEIGHT	CAGE CODE	DRAWING NO	RESTRICTED TO	CUSTOMER DRAWING	
			A1	00779	SCALE	3:5	SHEET 1 OF 1

CUSTOMER VIEWABLE ASSEMBLY