

LOC	DIST	REVISIONS					
GP	00	P	LTN	DESCRIPTION	DATE	DWN	APVD
		A		INITIAL RELEASE	23SEP2016	RG	SH

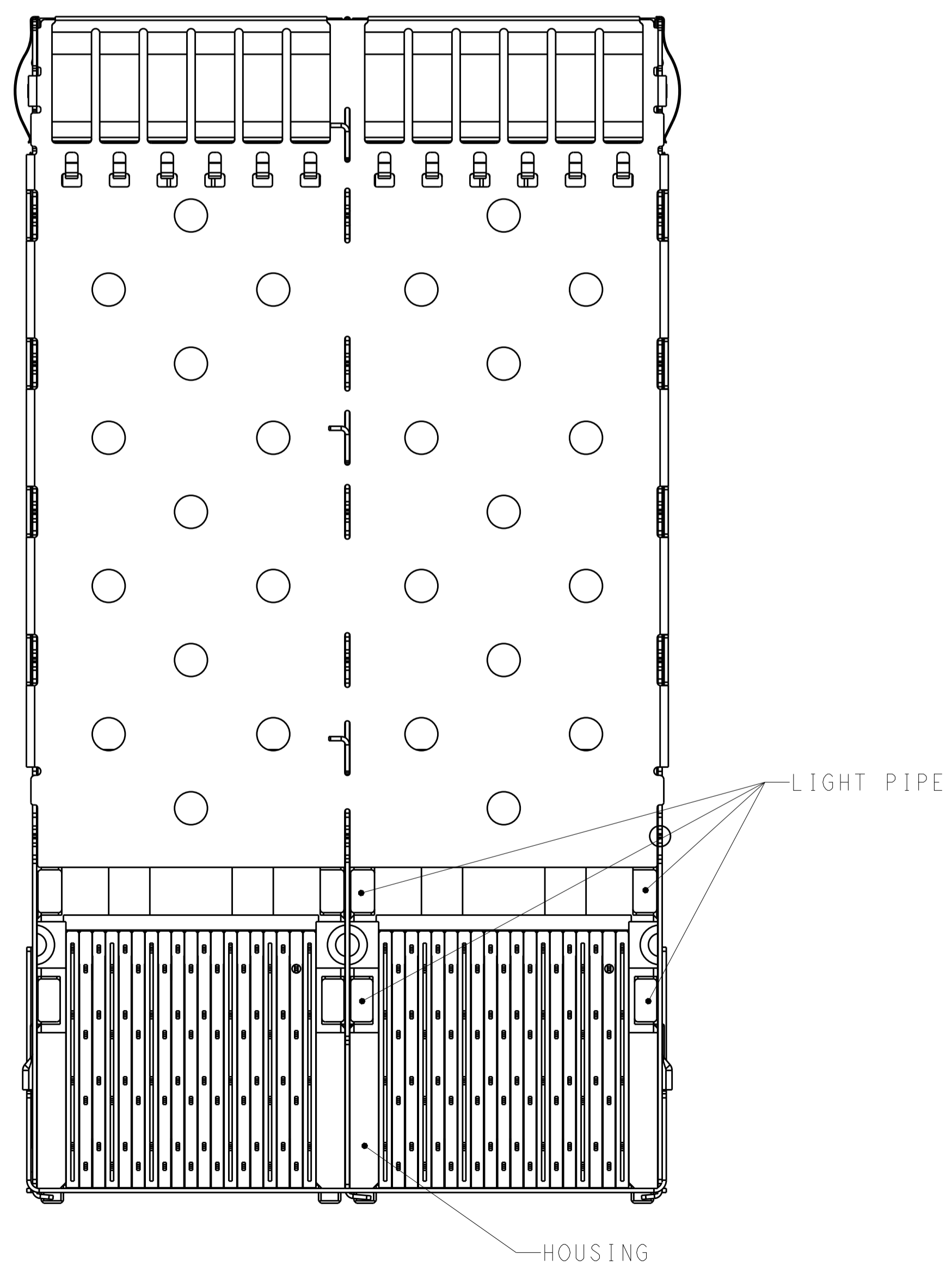
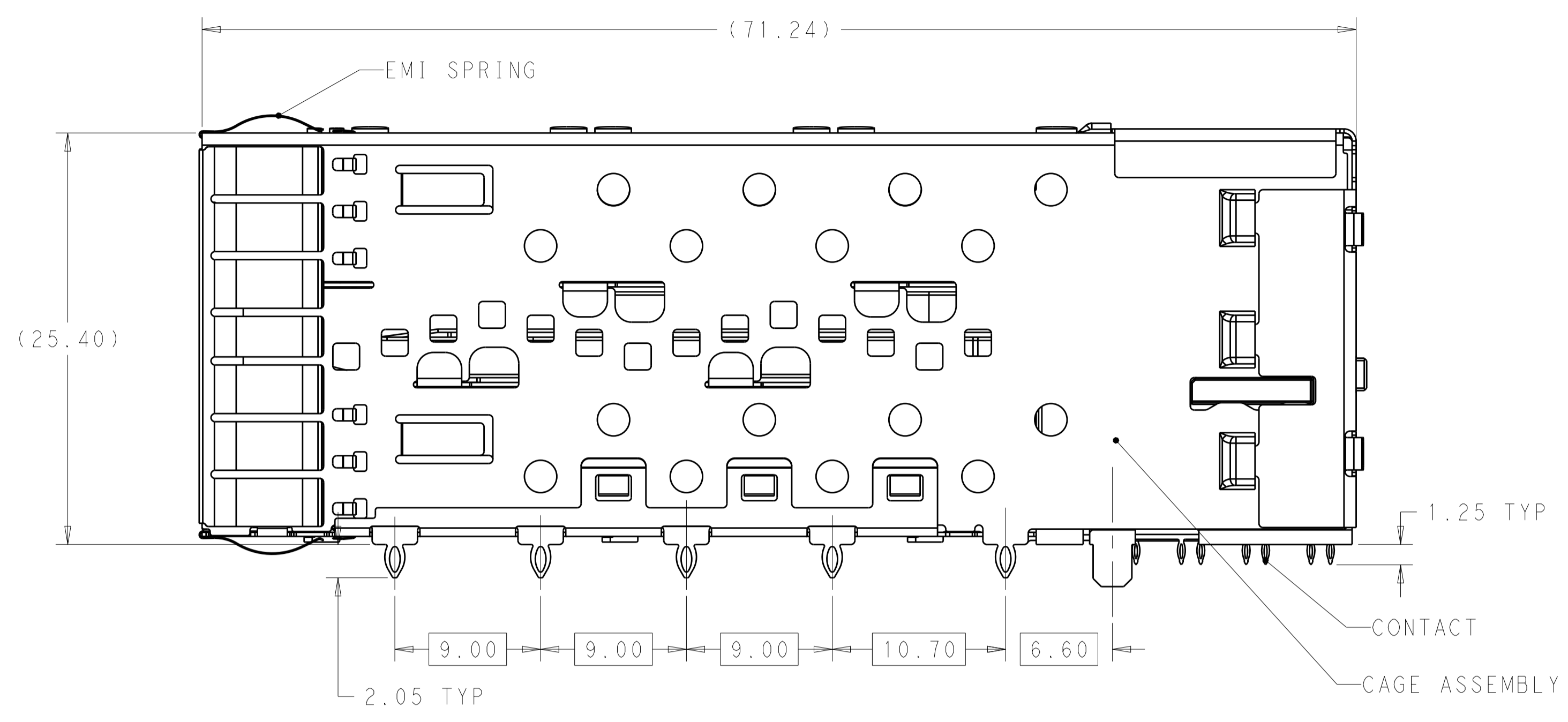
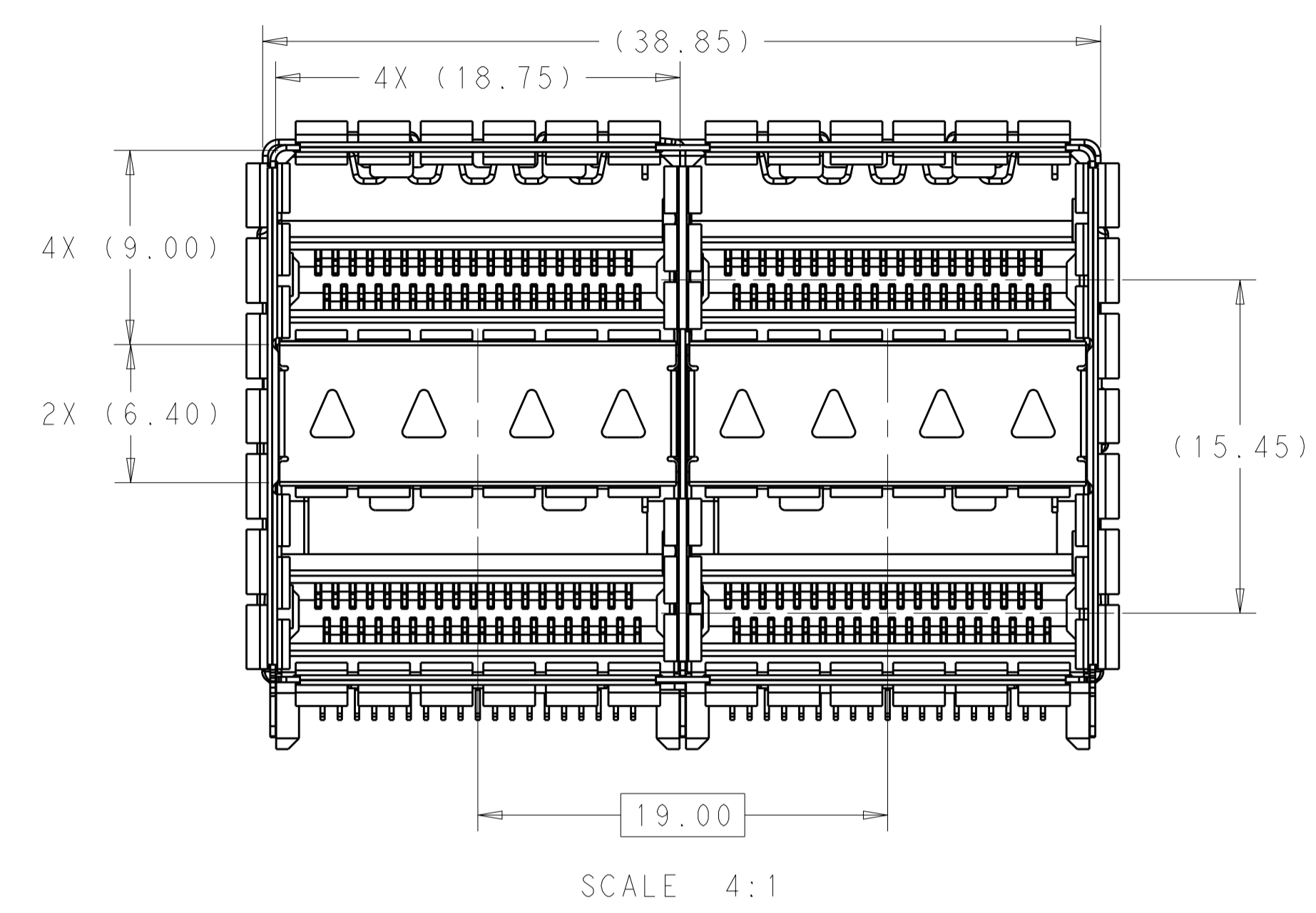

- 1 MATERIAL:  
 CAGE ASSEMBLY- STAINLESS STEEL.  
 EMI SPRING- COPPER ALLOY.  
 HOUSING- BLACK LCP,UL 94V-0 RATED  
 CHICKLET- BLACK LCP,UL 94V-0 RATED  
 LIGHT PIPE- POLYCARBONATE, CLEAR, UL 94V-0 RATED  
 CONTACT- COPPER ALLOY.
- 2 DATUM AND BASIC DIMENSIONS ESTABLISHED BY CUSTOMER.
- 3. MINIMUM PCB THICKNESS OF 1.57mm.
- 4 CONTACT FINISH- CONFORMS TO THE REQUIREMENTS OF TE PRODUCT SPECIFICATION 108-127010. BASED ON EIA/ECA-364-1000.01A, (CONTROLLED ENVIRONMENT APPLICATIONS) ON MATING INTERFACE, TIN ON NEEDLE EYE.
- 5 THE ENTIRE AREA OF THE CONNECTOR FOOTPRINT, INDICATED BY THE DASHED LINE, TO BE CONSIDERED THE KEEPOUT AREA FOR COMPONENTS AND SIGNAL TRACES. TOP SIDE ONLY. TOP SIDE TRACES ALLOWED WITHIN CONNECTOR HOLE PATTERN.
- 6 LIGHT PIPE PAD LAYOUT IS FOR 0805 LOW PROFILE LED PACKAGE WITH A HEIGHT OF 0.8mm.
- 7. CAGE FINISH-1.25 μm MINIMUM NICKEL PLATING.

4 LIGHT PIPES	2293961-5
4 LIGHT PIPES	2293961-4
NO LIGHT PIPE	2293961-3
2 LIGHT PIPE	2293961-2
4 LIGHT PIPES	2293961-1
DESCRIPTION	PART NUMBER

THIS DRAWING IS A CONTROLLED DOCUMENT. DWN: ROBERT\_GAN 23JUN2015  
 CHK: SEAN\_HAN 23JUN2015

DIMENSIONS:	TOLERANCES UNLESS OTHERWISE SPECIFIED:	APVD: SEAN_HAN 23JUN2015	NAME
mm	0 PLC ± .	PRODUCT SPEC	CAGE AND PT CONNECTOR ASSEMBLY
	1 PLC ± 0.25	APPLICATION SPEC	SPRING TYPE, PRESS FIT,
	2 PLC ± 0.15	SIZE	2X2, STACKED QSFP+
	3 PLC ± .	WEIGHT	
	4 PLC ± .	CUSTOMER DRAWING	
	ANGLES ± .	SCALE	1:1
	FINISH	SHEET	1 OF 4

MATERIAL: 1 FINISH: 4

STE TE Connectivity

100779C=2293961

LOC	DIST	REV	DATE	APP'D
GP	00			

REVISIONS		DATE	OWN	APP'D
P	LTH			
- SEE SHEET 1				

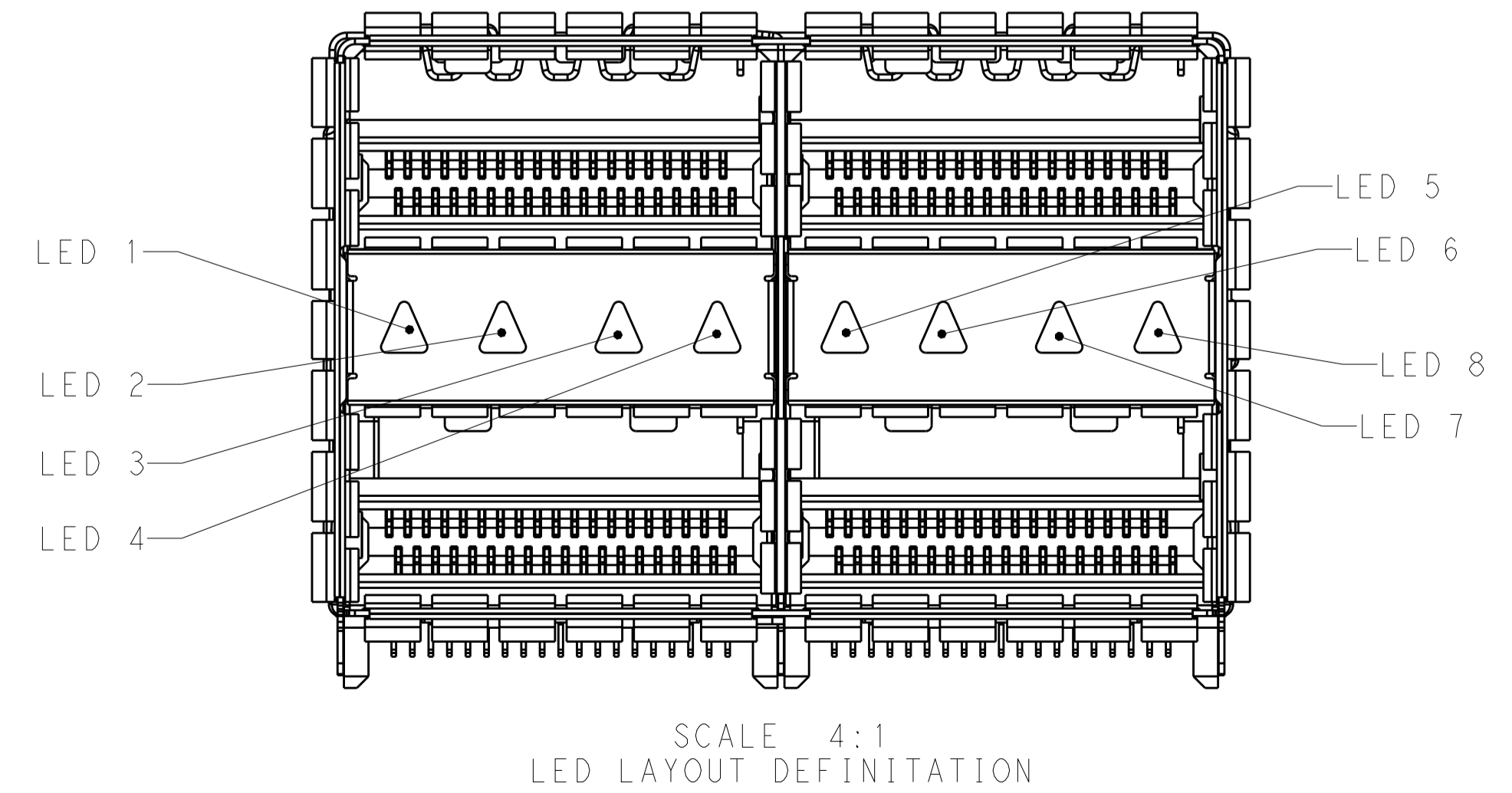
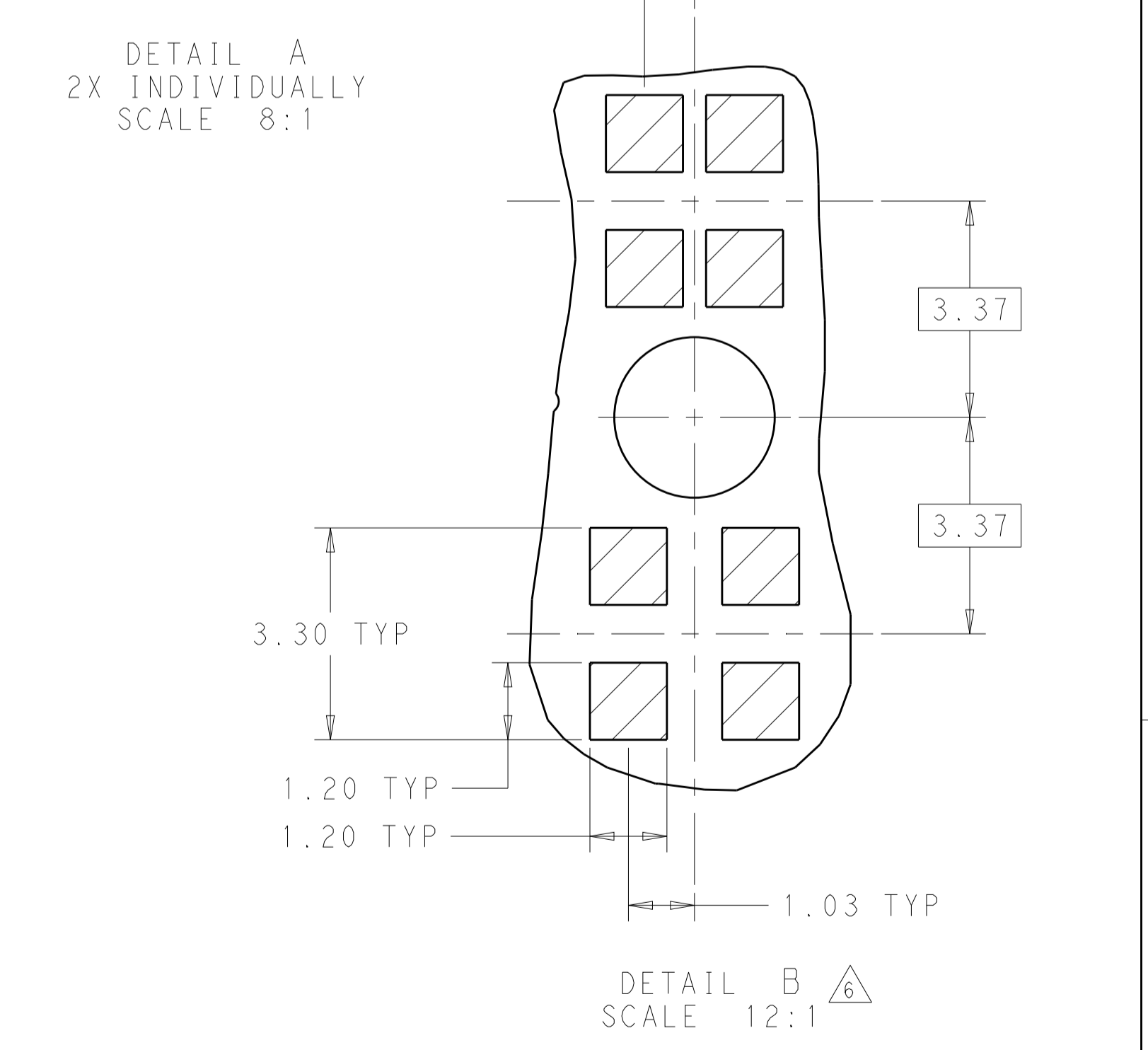
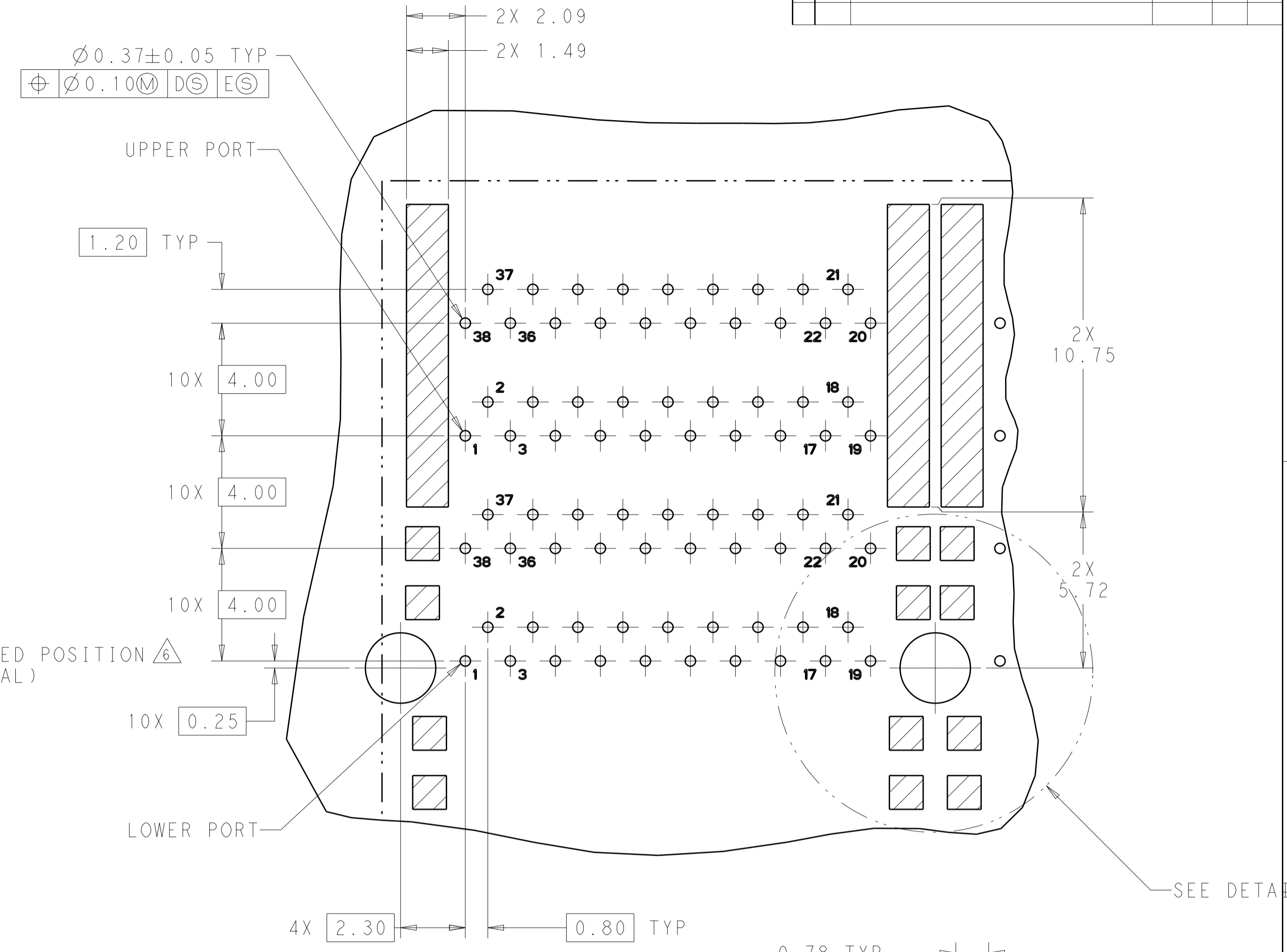
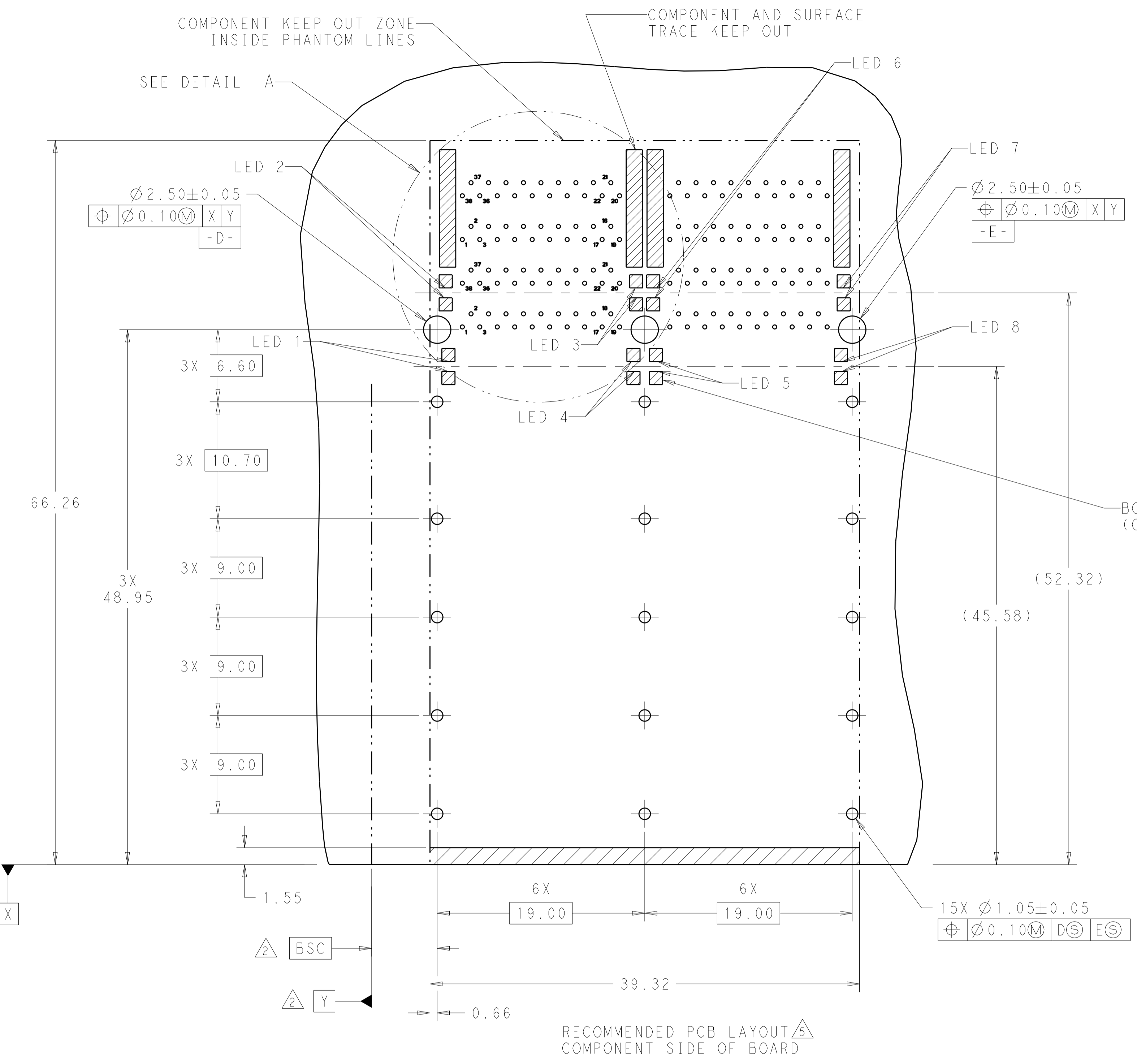

THIS PRINT IS  
**PRELIMINARY**  
 UNQUALIFIED PRODUCT  
 CONTACT PRODUCT ENGINEERING  
 BEFORE USING THIS PRINT

THIS DRAWING IS A CONTROLLED DOCUMENT.		OWN: ROBERT_GAN 23JUN2015	TE Connectivity
DIMENSIONS: mm		APVD: SEAN_HAN 23JUN2015	
TOLERANCES UNLESS OTHERWISE SPECIFIED:		NAME: CAGE AND PT CONNECTOR ASSEMBLY	108-127010 APPLICATION SPEC
0 PLC ±.1		PRODUCT SPEC	
1 PLC ±0.25		SIZE: CAGE CODE DRAWING NO	RESTRICTED TO A1 00779C=2293961
2 PLC ±0.15		WEIGHT	
3 PLC ±.1		CUSTOMER DRAWING	SCALE 1:1 SHEET 2 OF 4 REV A
4 PLC ±.1			
ANGLES ±.1			
MATERIAL FINISH			

LOC	DIST	REVISIONS					
		P	LTN	DESCRIPTION	DATE	DWN	APVD
GP	00	-	-	SEE SHEET 1	-	-	-

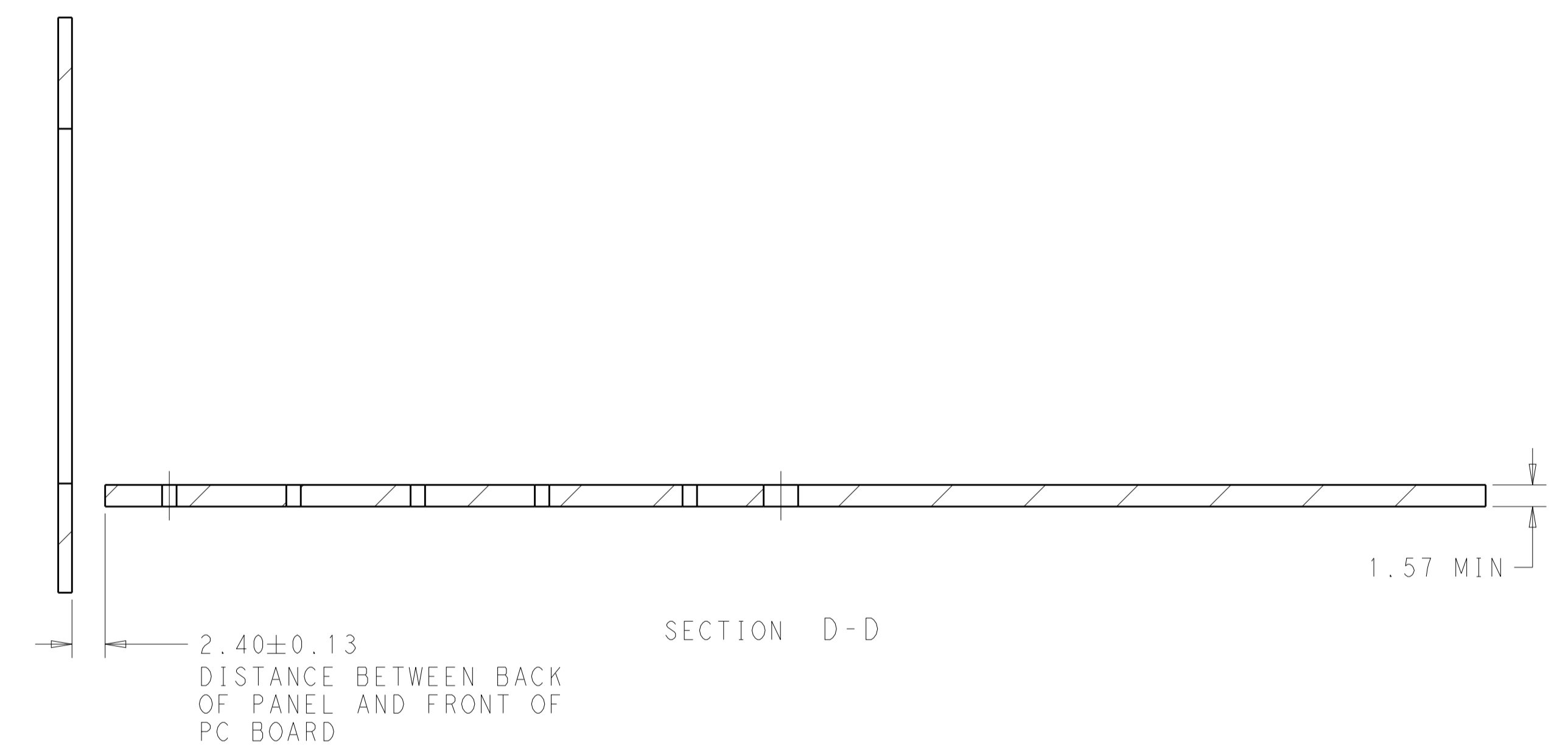
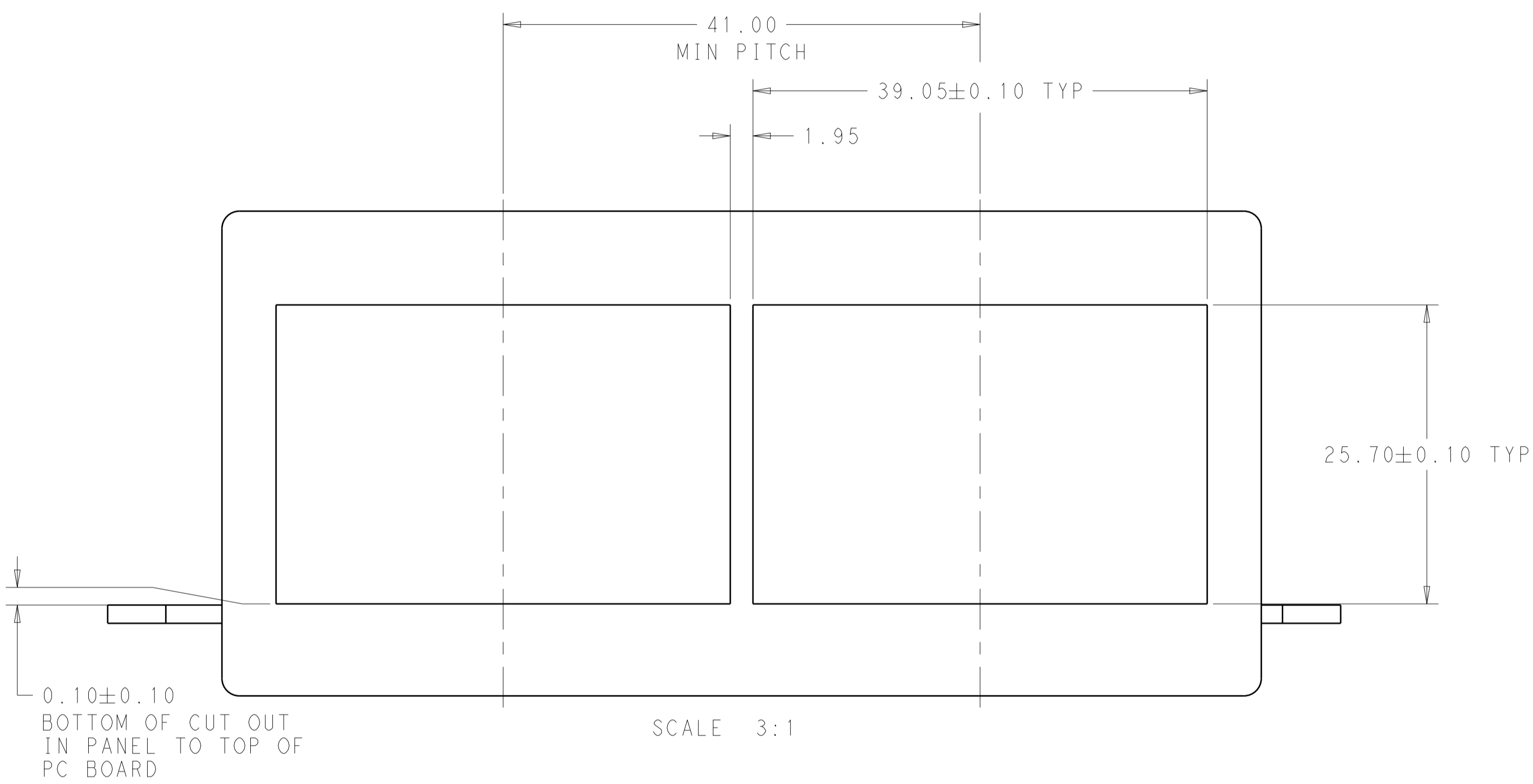

THIS PRINT IS  
**PRELIMINARY**  
 UNQUALIFIED PRODUCT  
 CONTACT PRODUCT ENGINEERING  
 BEFORE USING THIS PRINT

THIS DRAWING IS A CONTROLLED DOCUMENT.		OWN ROBERT_GAN	23JUN2015	
DIMENSIONS: mm		CHK SEAN_HAN	23JUN2015	
TOLERANCES UNLESS OTHERWISE SPECIFIED: 0 PLC ±. 1 PLC ±0.25 2 PLC ±0.15 3 PLC ±. 4 PLC ±. ANGLES ±.		APVD SEAN_HAN	23JUN2015	NAME CAGE AND PT CONNECTOR ASSEMBLY SPRING TYPE, PRESS FIT, 2X2, STACKED QSFP+
MATERIAL		PRODUCT SPEC 108-127010	APPLICATION SPEC 114-32020	SIZE A1
FINISH		WEIGHT C=2293961	CAGE CODE 2293961	RESTRICTED TO -
		CUSTOMER DRAWING		SCALE 1:1 SHEET 3 OF 4 REV A

LOC	DIST	REVISIONS					
GP	00	P	LYR	DESCRIPTION	DATE	DMN	APVD
-	-	-	-	SEE SHEET 1	-	-	-

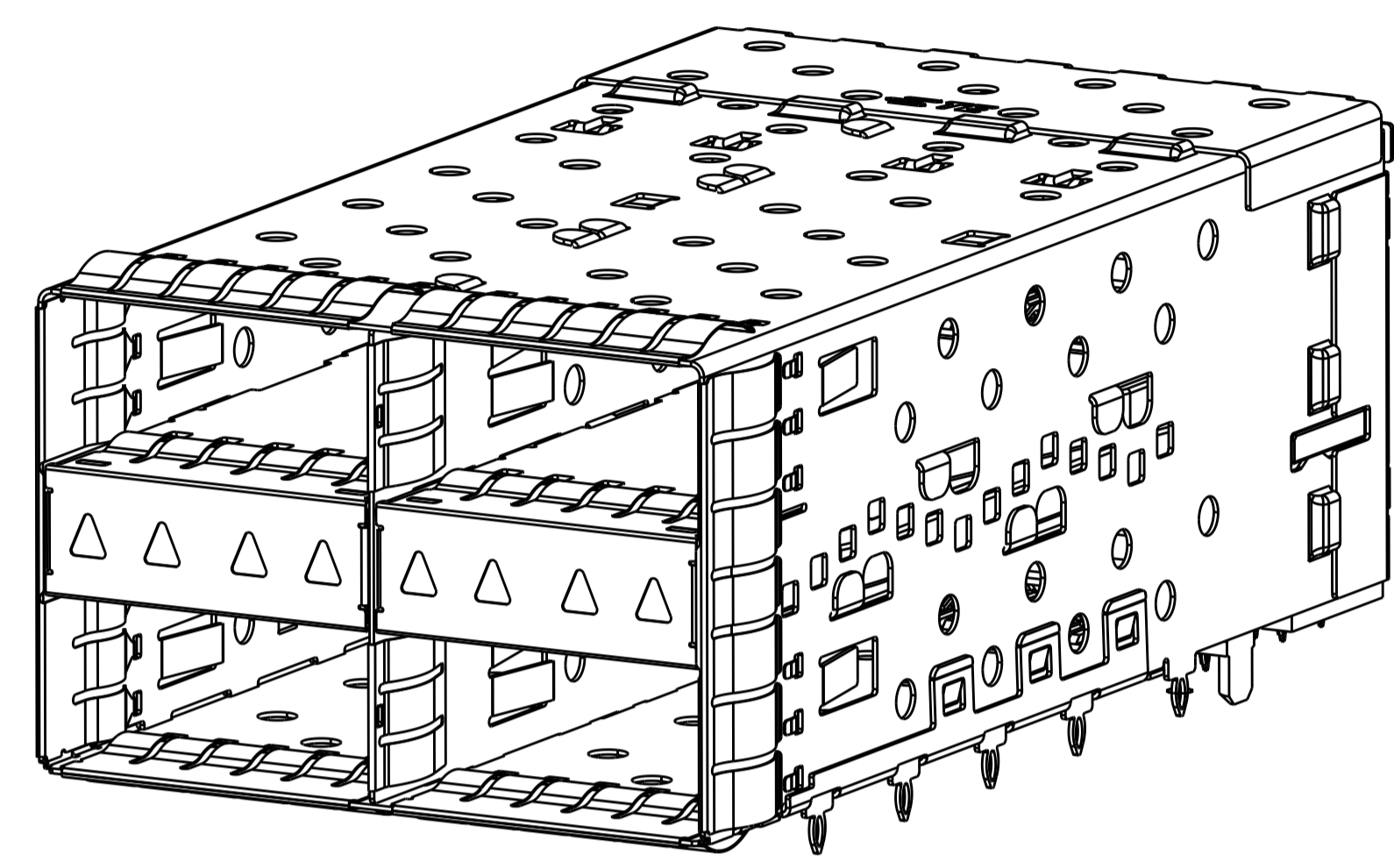

2293961-1  
SCALE 3:1

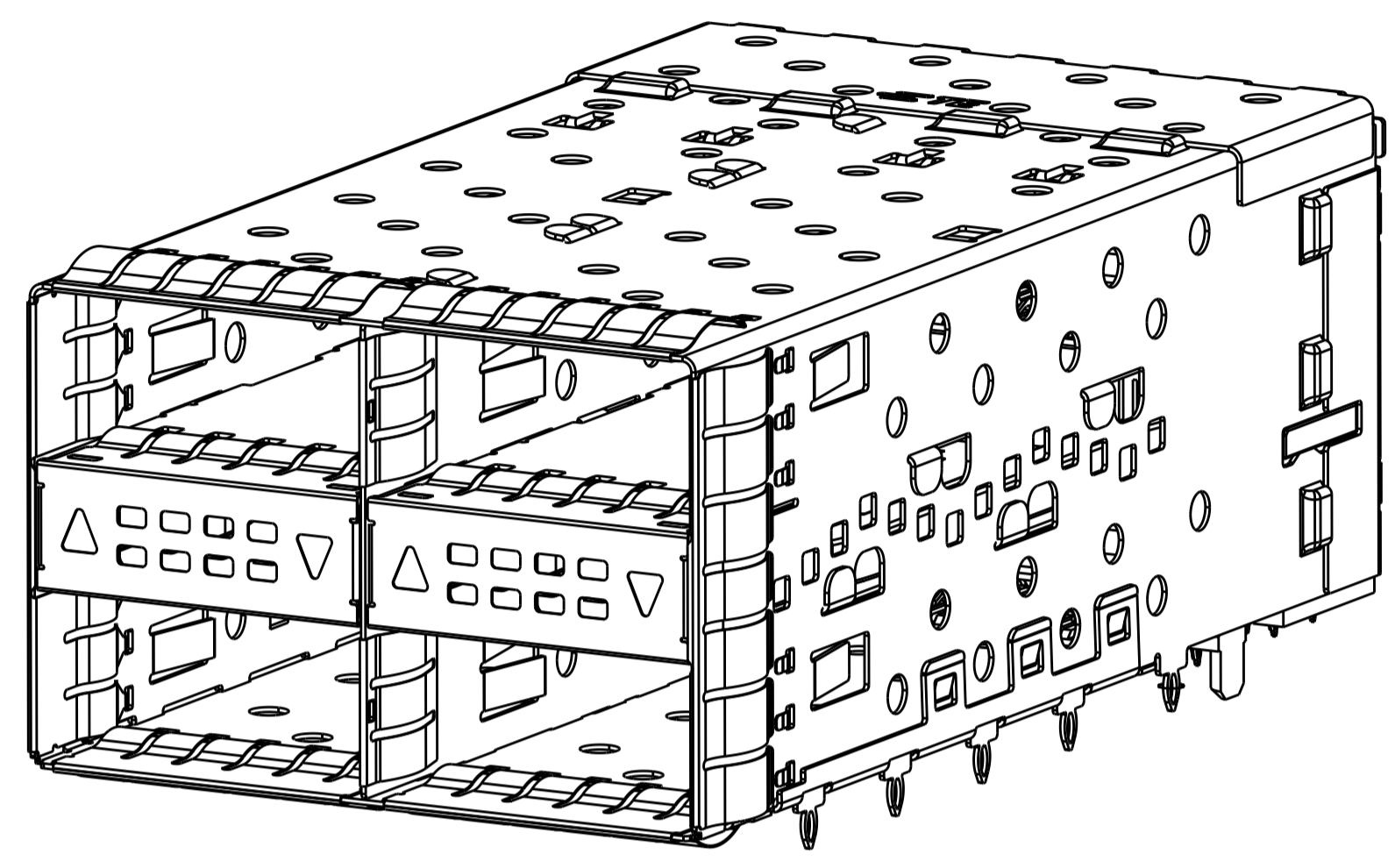

2293961-2  
SCALE 3:1

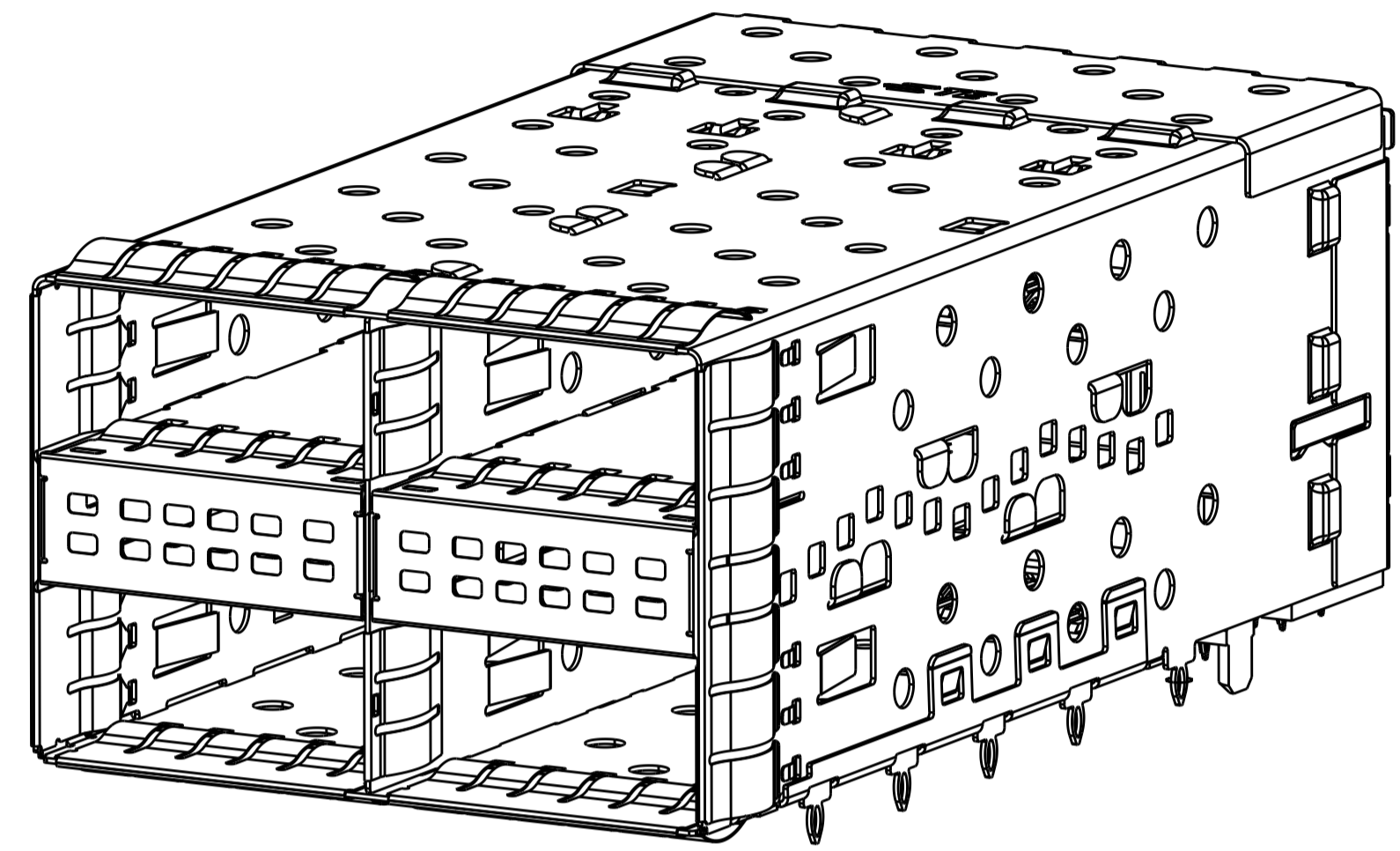

2293961-3  
SCALE 3:1

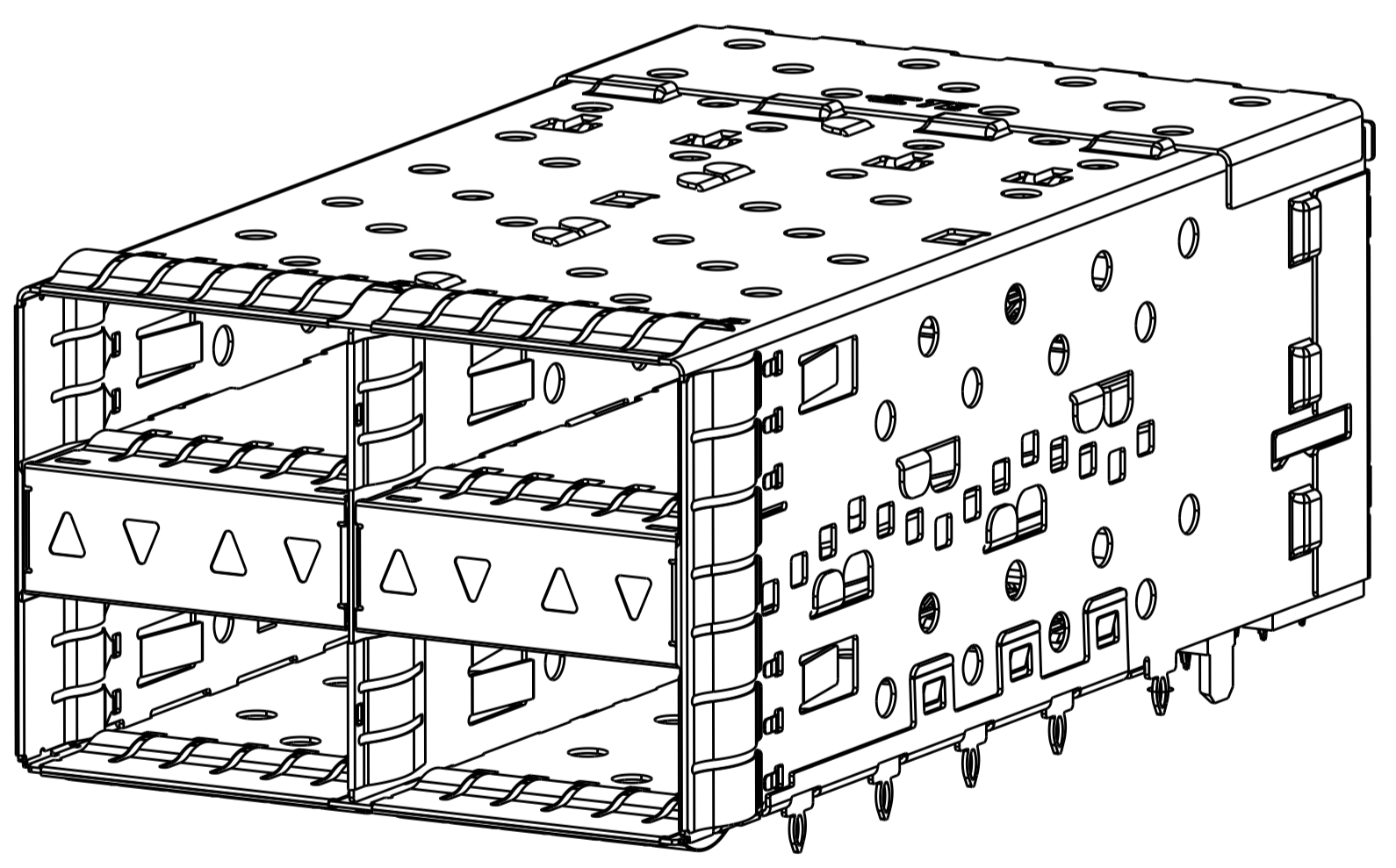

2293961-4  
SCALE 3:1

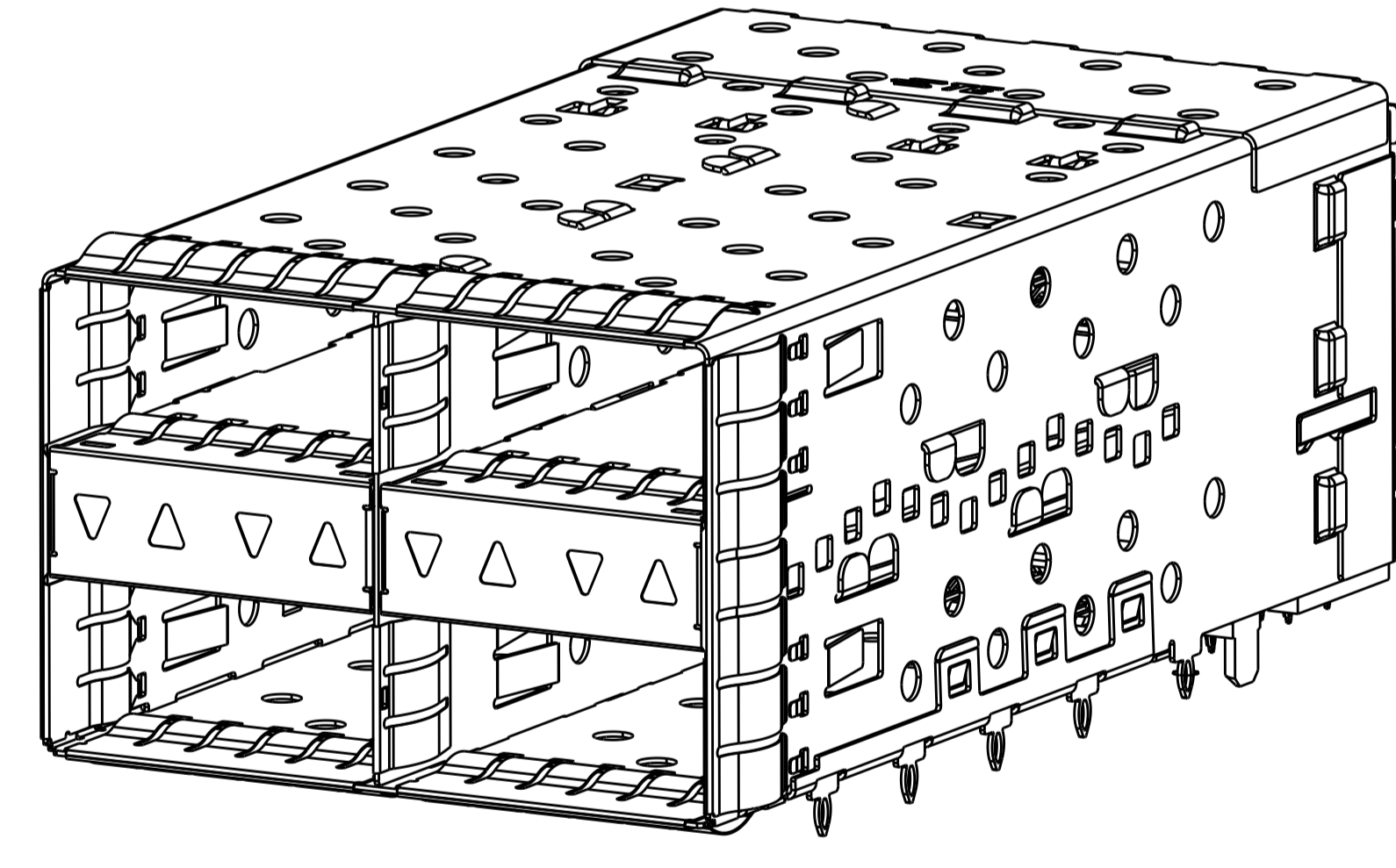

2293961-5  
SCALE 3:1

THIS DRAWING IS A CONTROLLED DOCUMENT.		DMN ROBERT_GAN	23JUN2015	<b>STE</b> TE Connectivity
DIMENSIONS:		CHK		
mm	TOLERANCES UNLESS OTHERWISE SPECIFIED:	APVD SEAN_HAN	23JUN2015	NAME CAGE AND PT CONNECTOR ASSEMBLY SPRING TYPE, PRESS FIT, 2X2, STACKED QSFP+
0 PLC ±	0.25	PRODUCT SPEC		
1 PLC ±	0.15	108-127010		SIZE A1
2 PLC ±		APPLICATION SPEC		
3 PLC ±		114-32020		CAGE CODE DRAWING NO 00779
4 PLC ±		WEIGHT		
ANGLES ±		CUSTOMER DRAWING		SCALE 1:1 SHEET 4 OF 4 REV A
FINISH				