

APPLICATION SPECIFICATION
PicoBlade 1.25 DIP TYPE & SMT TYPE

This application specification is written in English and Japanese.
本取扱説明書は、英文および和文で記載されております。
English 英文: Page 1~28
Japanese 和文: Page 29~57

[1.APPLICATION]

	Product Name		Part Number
HARNESS SIDE	RECEPTACLE HOUSING		51021 series
	RECEPTACLE CRIMP TERMINAL	AWG#28-32	50058 series
		AWG#26-28	50079 series
	APPLICABLE WIRE (※)		AWG#26~32 Tin plated stranded wire
	APPLICABLE CRIMP DIE MODEL No. (※)		57067-3**0
ONBOARD SIDE	HEADER ASS'Y	ST TYPE	53047 series
	DIP TYPE	R/A TYPE	53048 series
	HEADER ASS'Y	ST TYPE	53398 series
	SMT TYPE	R/A TYPE	53261 series

※ Please refer to crimp specification for further details.

— Before using —

- Be sure to read the following precautions before using connector.
- Keep this manual for reference at any time.
- The displays and illustrations shown in this manual are for illustrative purposes only and may differ from the actual product.
- The contents of this manual are subject to change without notice.
- If you find any mistake or there is anything that is not clear, please contact your sales representative.

REV.	A																			
SHEET	1-58																			
REVISE ON PC ONLY										TITLE:										
A	RELEASED 新規作成 602794 2018/11/02 S.OBARA									PicoBlade 1.25 DIP TYPE & SMT TYPE APPLICATION SPECIFICATION										
	THIS DOCUMENT CONTAINS INFORMATION THAT IS PROPRIETARY TO MOLEX ELECTRONIC TECHNOLOGIES, LLC AND SHOULD NOT BE USED WITHOUT WRITTEN PERMISSION																			
REV.	DESCRIPTION																			
DESIGN CONTROL J					STATUS					WRITTEN BY: SOBARA01	CHECKED BY: A.IDA	APPROVED BY: T.KANEKO	DATE: 2018/08/13							
DOCUMENT NUMBER 510210000-AS										DOC. TYPE PS	DOC. PART 000	CUSTOMER GENERAL						SHEET 1 OF 58		
EN-127(2015-12)																				

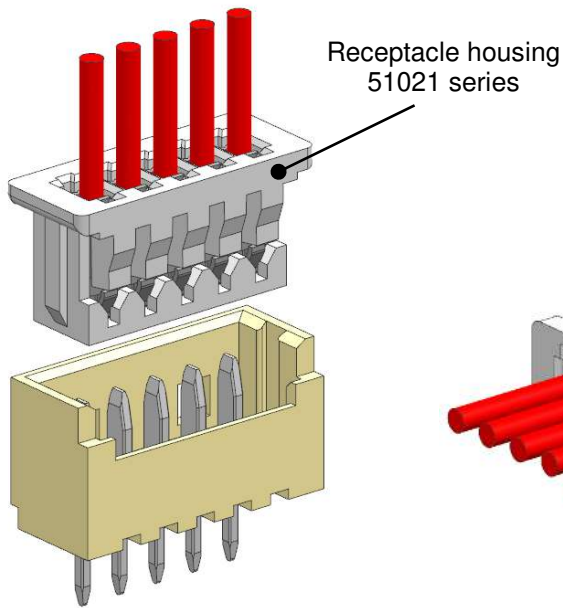

DIP ST TYPE
53047 series

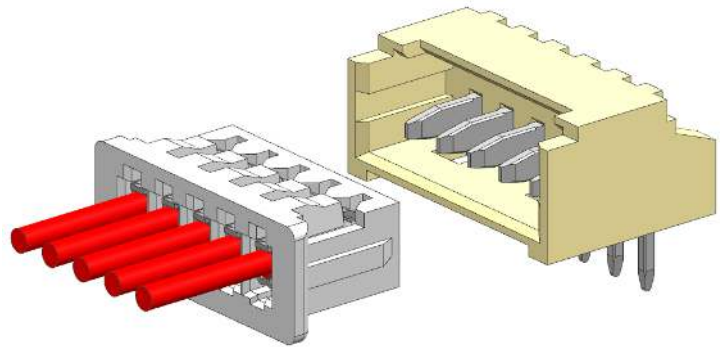

DIP R/A TYPE
53048 series

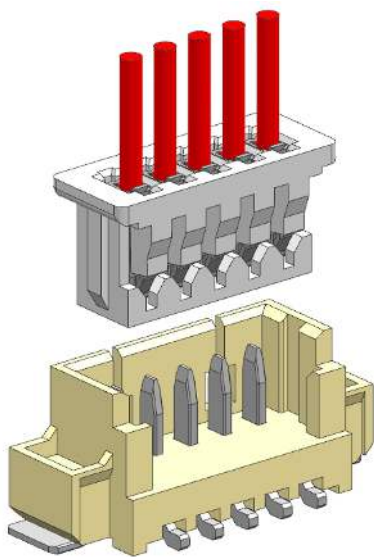

SMT ST TYPE
53398 series

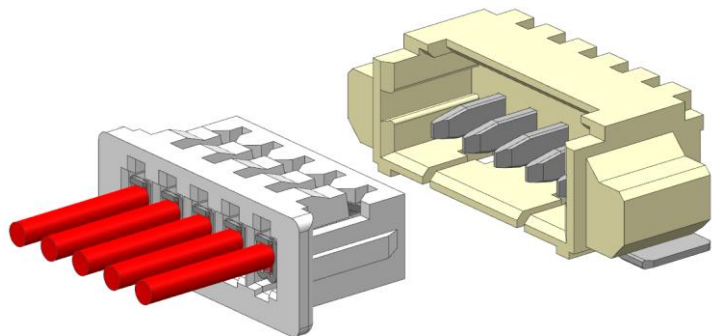

SMT R/A TYPE
53261 series

REVISE ON PC ONLY		TITLE: PicoBlade 1.25 DIP TYPE & SMT TYPE APPLICATION SPECIFICATION			
A	SEE SHEET 1 OF 58				
REV.	DESCRIPTION	THIS DOCUMENT CONTAINS INFORMATION THAT IS PROPRIETARY TO MOLEX ELECTRONIC TECHNOLOGIES, LLC AND SHOULD NOT BE USED WITHOUT WRITTEN PERMISSION			
DOCUMENT NUMBER 510210000-AS		DOC. TYPE PS	DOC. PART 000	CUSTOMER GENERAL	SHEET 2 OF 58
EN-127(2015-12)					

Contents

1. <u>Application</u>	P-1
2. <u>Instructions</u>	
2-1. <u>Product exterior</u>	P-4
2-2. <u>Applicable wire and crimp tooling</u>	P-4
2-3. <u>About safekeeping before harness process and surface mount process</u>	P-4
2-4. <u>Harness process and surface mount process instruction.</u>	P-5~6
2-5. <u>About use in the machinery.</u>	P-6
2-6. <u>About rating / performance standard.</u>	P-6
2-7. <u>Use of the product.</u>	P-6
3. <u>The name of each part & explanation</u>	
3-1. <u>Receptacle crimp terminal</u>	P-7
3-2. <u>Receptacle housing</u>	P-8
3-3. <u>Header assembly DIP type</u>	P-9
3-4. <u>Header assembly SMT type</u>	P-10
4. <u>The confirmation item for crimping wire</u>	
4-1. <u>The appearance before crimping.</u>	P-11
4-2. <u>The appearance after crimping.</u>	P-11
4-3. <u>Crimping failure</u>	P-12~14
5. <u>Wire bundling and package after crimping</u>	P-15
6. <u>Harness processing (crimping wire insertion method in Receptacle housing)</u>	
6-1 <u>Insertion crimping wire</u>	P-16~19
6-2. <u>Repair of crimp terminal</u>	P-20
7. <u>Banding of harness</u>	P-21~22
8. <u>Packing method of harness</u>	P-23~24
9. <u>Instructions of mounting on P.C.B.</u>	P-25
10. <u>Instruction when mating with HDR connector</u>	
10-1. <u>Mating process method</u>	P-26
10-2. <u>Un-mating process method</u>	P-27
10-3. <u>Wiring after mating</u>	P-27~28

REVISE ON PC ONLY		TITLE: PicoBlade 1.25 DIP TYPE & SMT TYPE APPLICATION SPECIFICATION			
A	SEE SHEET 1 OF 58				
REV.	DESCRIPTION	THIS DOCUMENT CONTAINS INFORMATION THAT IS PROPRIETARY TO MOLEX ELECTRONIC TECHNOLOGIES, LLC AND SHOULD NOT BE USED WITHOUT WRITTEN PERMISSION			
DOCUMENT NUMBER 510210000-AS		DOC. TYPE PS	DOC. PART 000	CUSTOMER GENERAL	SHEET 3 OF 58
EN-127(2015-12)					

[2.Instructions]

2-1. Product exterior

1. There is no influence on the product performance if black spots, bubbles might be on the plastic part of this product, or different color tone including discoloration by secular change.
2. Slide marks may sometimes appear on plating part of the product, but there is no impact on the function of this product.
3. Resin and terminal plating may have some changes in color after soldering, but there is no negative impact on the function of this product.
4. Connectors may be damaged by inappropriate force of the mounting machine. Please confirm that there is no problem before using.

2-2. Applicable wire and crimp tooling

1. Guarantee is void when product is used with wire out of application range specified in the product specifications.
2. Guarantee is void when product is used with non Molex authorized tooling.
3. Recommended electric wire is tin plated stranded copper wire.

2-3. About safekeeping before harness process and surface mount process

1. Please keep product as it is delivered and packaged. Also, please keep it under normal temperature and humidity away from direct sunlight.
2. Please do not allow external force on product and package during the storage.
3. During handling, avoid shock or dropping products as it may cause damage.
4. First-in, first-out of the stock is recommended.
5. Keep product in original packaging until using.
6. This product should be inspected its appearance and solder performance before using after storage expiration date.

REVISE ON PC ONLY		TITLE: PicoBlade 1.25 DIP TYPE & SMT TYPE APPLICATION SPECIFICATION			
A	SEE SHEET 1 OF 58				
REV.	DESCRIPTION	THIS DOCUMENT CONTAINS INFORMATION THAT IS PROPRIETARY TO MOLEX ELECTRONIC TECHNOLOGIES, LLC AND SHOULD NOT BE USED WITHOUT WRITTEN PERMISSION			
DOCUMENT NUMBER 510210000-AS		DOC. TYPE PS	DOC. PART 000	CUSTOMER GENERAL	SHEET 4 OF 58
EN-127(2015-12)					

2-4. Harness process and surface mount process instruction.

1. Please confirm if the products and crimp machine, crimp condition, an applicable wire are equal to product drawing, crimp specifications before use.
2. Beware of dust, debris, or foreign objects on the product, or deformation of the product before using. It may result in insufficient of the insertion performance to the housing and electric performance.
3. Please do not touch the terminal by bare hand.
4. When a terminal is twisted or tangled, please do not handle it by too much force. The terminal may become damaged.
5. Do not apply force to the product during work in process or in finishing goods. Product may be damaged and may not function properly as a connector.
6. Please do not expose a product including a harness half-finished goods to the following condition.
 - Dust
 - Corrosive material
 - Corrosive gas
 - High temperature and high humidity
 - Direct sunlight

The above conditions may cause poor contact, corrosion of the terminal and the insulation performance deterioration of the housing. Please keep in boxes.
7. Please do not add loads to connector, harness and half-finished goods during production, packaging, transportation, or storage. It may cause damage and result in poor performance.
8. Do not apply excessive force or tension to avoid damage to the contact part, crimp part, or lance part when pulling a wire of a harness or a half-finished goods.
9. Do not damage receptacle housing and a crimp terminal intentionally. Product performance can be affected by this condition.
10. Please use receptacle housing within the day of its package is opened. Moisture absorption or drying may cause the deterioration of materials by neighboring atmospheres. When you cannot use it up, please seal the bag again and keep it in a box.
11. Please be careful not to be injured with the edges part such as metal parts when handling a connector.
12. To avoid injury, please be careful when handling the paper between terminals and metal carrier on reels.
13. Our evaluation is with the use of standard rigid PCB. When the product is used on flexible printed circuits (FPC) please evaluate in advance.
14. Please solder all the terminal departments and the nail part (SMT type). Non-soldered part may cause defect.
15. In the case of changing our recommended board pattern size or design, please consult us in advance because such changes may cause defects.
16. Please do not apply to load for connector. For example, carrying the PCB when connector is mated may cause damage.
17. Please do not stack PCB after connector is soldered to PCB.
18. Please follow the conditions in product specifications, when you use a soldering iron. For conditions exceeding specifications, the connector may be damaged.

REVISE ON PC ONLY		TITLE: PicoBlade 1.25 DIP TYPE & SMT TYPE APPLICATION SPECIFICATION	THIS DOCUMENT CONTAINS INFORMATION THAT IS PROPRIETARY TO MOLEX ELECTRONIC TECHNOLOGIES, LLC AND SHOULD NOT BE USED WITHOUT WRITTEN PERMISSION		
A	SEE SHEET 1 OF 58				
REV.	DESCRIPTION				
DOCUMENT NUMBER 510210000-AS		DOC. TYPE PS	DOC. PART 000	CUSTOMER GENERAL	SHEET 5 OF 58
EN-127(2015-12)					

19. When you use a solder iron, please do not use excessive solder and flux. It may cause poor contact performance by solder wicking and flux wicking.
20. Depending on soldering conditions, resin discoloration and appearance change of plating may occur, but it does not degrade product performance.

2-5. About use in the machinery.

1. Vibration of an electric wire or printed circuit board due to machinery vibration or rotation must be avoided to prevent damage to connector at contact area. Contact failure due to abrasion may be caused. Therefore, please fix electric wires and printed circuit boards in the machinery and take measures to hold resonances.
2. Do not fix printed circuit boards by using only connectors. They must be fixed or supported by other means.
3. Please do not touch terminals and fitting nails (SMT type) before and after mounting on the circuit board.
4. Please insert and withdraw connector along fixed axis. The diagonal insertion and withdrawal cause damage to the connector.
5. After mating, do not intentionally apply force to span or rotate a connector. Such force may cause damage to connector or solder cracking.
6. If electric wire is pulled after mating a connector, it may damage contact or crimping areas or the lock area and result in contact failure. When performing the guidance wiring of the electric wire. Please keep the wire loose to avoid applying excessive force and tension to connector.
7. Mold lances may be damaged after removing crimp terminals. Therefore, please use a new housing when repairing a connector.

2-6. About rating / performance standard.

1. Please use the product within the rating / the standard of product specifications.
2. This product is not designed for usage in “hot-swap” applications where power is on.
3. Before using, please confirm that this product satisfies the equipment specifications.
4. In order to avoid short circuits, please do not allow connectors to contact with metal objects.
5. Please avoid to use current higher than the rated current.

2-7. Use of the product.

1. This product is not designed and produced for the machine to be used under the condition involving human lives or for the use of system. If you use this product for special use such as medical, aerospace and nuclear power etc., please confirm us before using.
2. Please contact us without fail before using if you plan to use the product for automobile and ship etc. (We will consider if the product can be applied to such specification condition.)
3. Please avoid using the product outdoors or under similar environment.

REVISE ON PC ONLY		TITLE: PicoBlade 1.25 DIP TYPE & SMT TYPE APPLICATION SPECIFICATION			
A	SEE SHEET 1 OF 58				
REV.	DESCRIPTION	THIS DOCUMENT CONTAINS INFORMATION THAT IS PROPRIETARY TO MOLEX ELECTRONIC TECHNOLOGIES, LLC AND SHOULD NOT BE USED WITHOUT WRITTEN PERMISSION			
DOCUMENT NUMBER 510210000-AS		DOC. TYPE PS	DOC. PART 000	CUSTOMER GENERAL	SHEET 6 OF 58
EN-127(2015-12)					

[3. The name of each part & explanation]

※ Please refer to sales drawing for product form and its dimensions.

3-1. Receptacle crimp terminal : 50058, 50079 series.

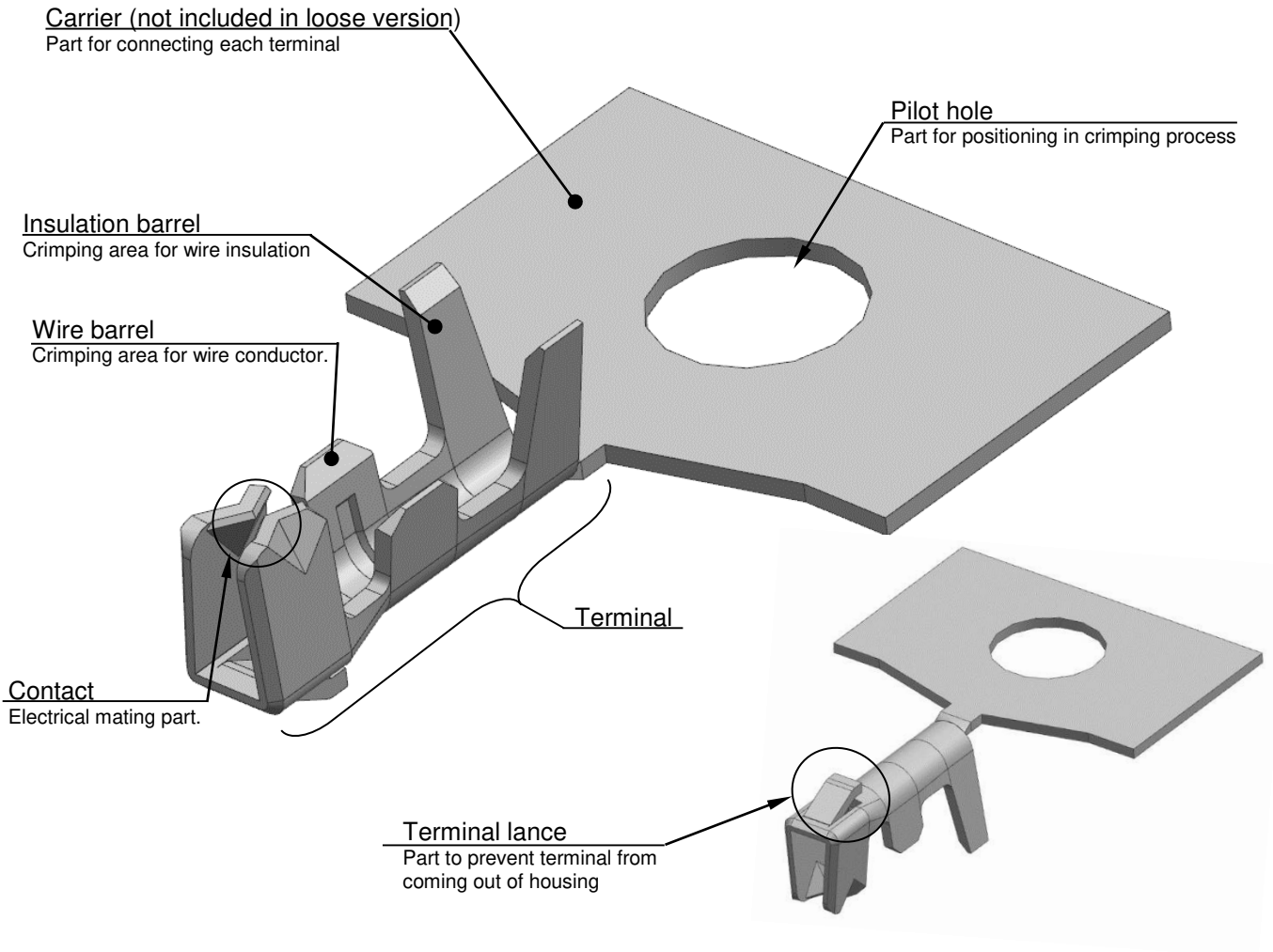

Fig. 3-1 Receptacle crimp terminal

REVISE ON PC ONLY		TITLE: PicoBlade 1.25 DIP TYPE & SMT TYPE APPLICATION SPECIFICATION			
A	SEE SHEET 1 OF 58				
REV.	DESCRIPTION	THIS DOCUMENT CONTAINS INFORMATION THAT IS PROPRIETARY TO MOLEX ELECTRONIC TECHNOLOGIES, LLC AND SHOULD NOT BE USED WITHOUT WRITTEN PERMISSION			
DOCUMENT NUMBER 510210000-AS		DOC. TYPE PS	DOC. PART 000	CUSTOMER GENERAL	SHEET 7 OF 58
EN-127(2015-12)					

3-2. Receptacle housing : 51021 series

Mold lance

Part to prevent terminal from coming out of housing

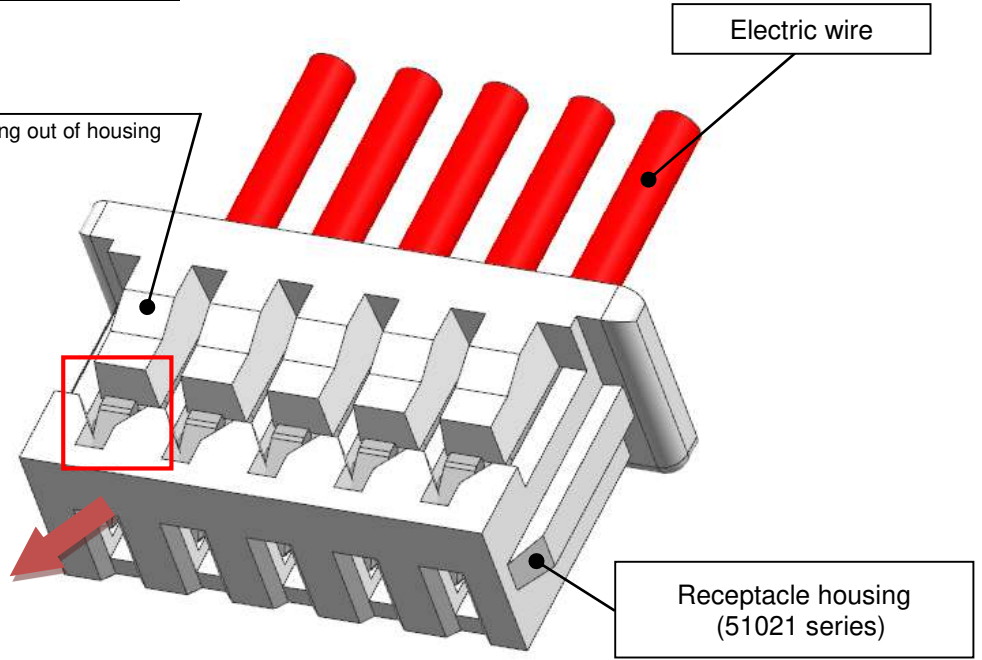
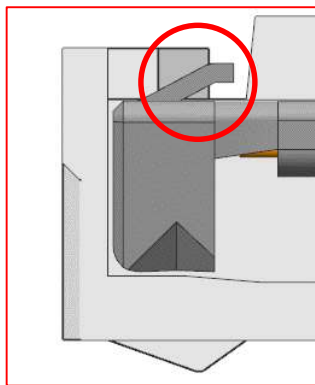

Friction Lock

Lock structure not to come off accidentally after mating

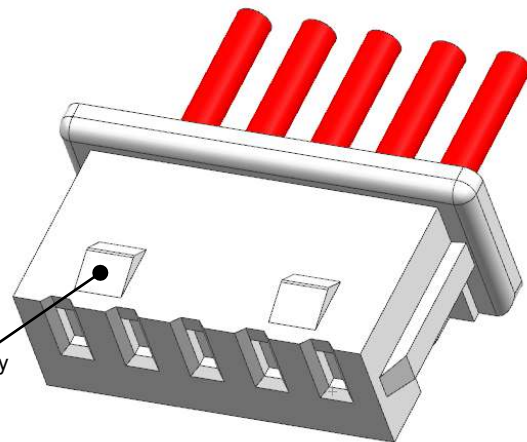

Fig. 3-2 Receptacle housing

REVISE ON PC ONLY		TITLE: PicoBlade 1.25 DIP TYPE & SMT TYPE APPLICATION SPECIFICATION			
A	SEE SHEET 1 OF 58				
REV.	DESCRIPTION	THIS DOCUMENT CONTAINS INFORMATION THAT IS PROPRIETARY TO MOLEX ELECTRONIC TECHNOLOGIES, LLC AND SHOULD NOT BE USED WITHOUT WRITTEN PERMISSION			
DOCUMENT NUMBER 510210000-AS		DOC. TYPE PS	DOC. PART 000	CUSTOMER GENERAL	SHEET 8 OF 58
EN-127(2015-12)					

3-3. Header Assembly SMT type

DIP ST type: 53047 series

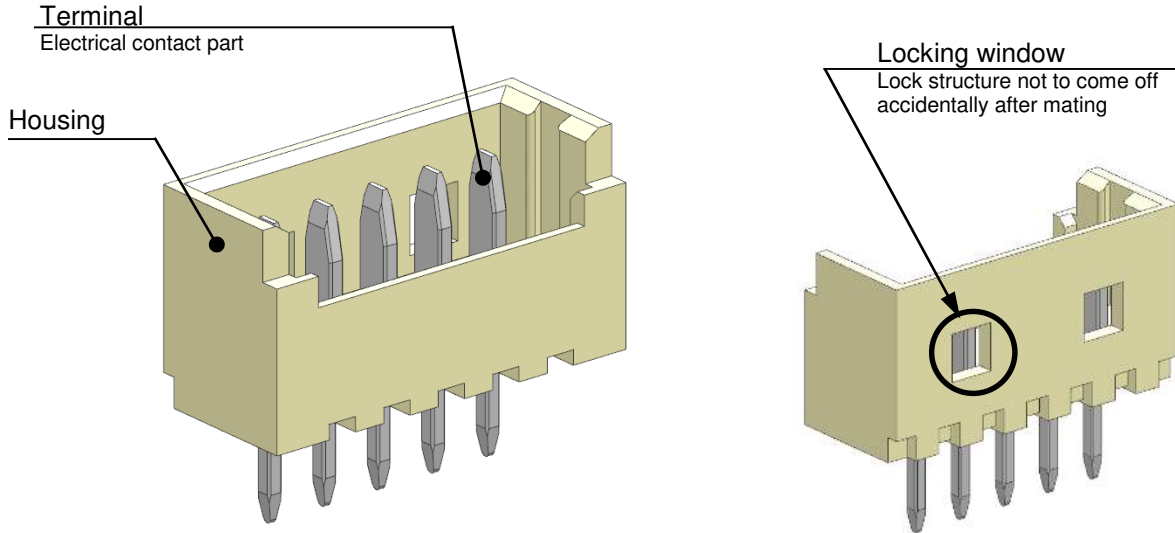

Fig. 3-3 DIP ST type: 53047 series

DIP R/A type: 53048 series

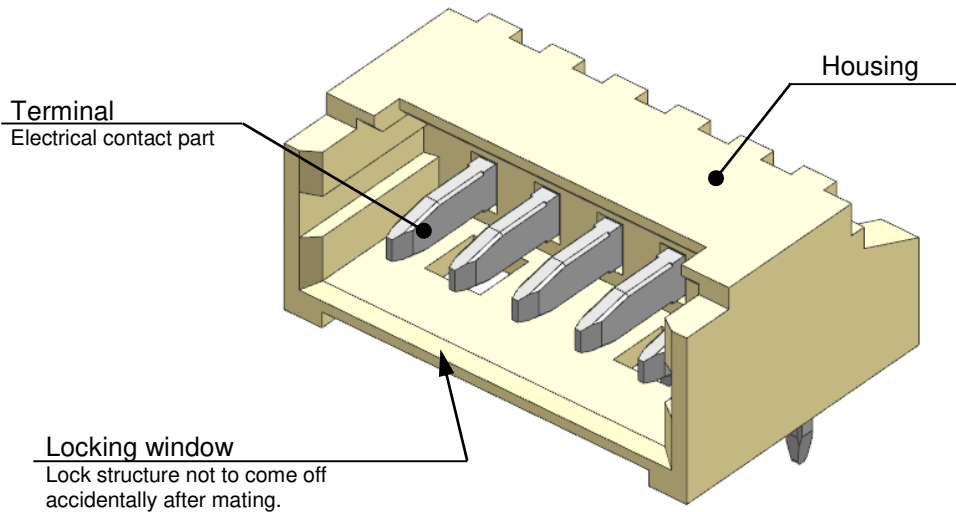

Fig. 3-4 DIP R/A type: 53048 series

REVISE ON PC ONLY		TITLE: PicoBlade 1.25 DIP TYPE & SMT TYPE APPLICATION SPECIFICATION			
A	SEE SHEET 1 OF 58				
REV.	DESCRIPTION	THIS DOCUMENT CONTAINS INFORMATION THAT IS PROPRIETARY TO MOLEX ELECTRONIC TECHNOLOGIES, LLC AND SHOULD NOT BE USED WITHOUT WRITTEN PERMISSION			
DOCUMENT NUMBER 510210000-AS		DOC. TYPE PS	DOC. PART 000	CUSTOMER GENERAL	SHEET 9 OF 58
EN-127(2015-12)					

3-4. Header Assembly SMT type

SMT ST type: 53398 series

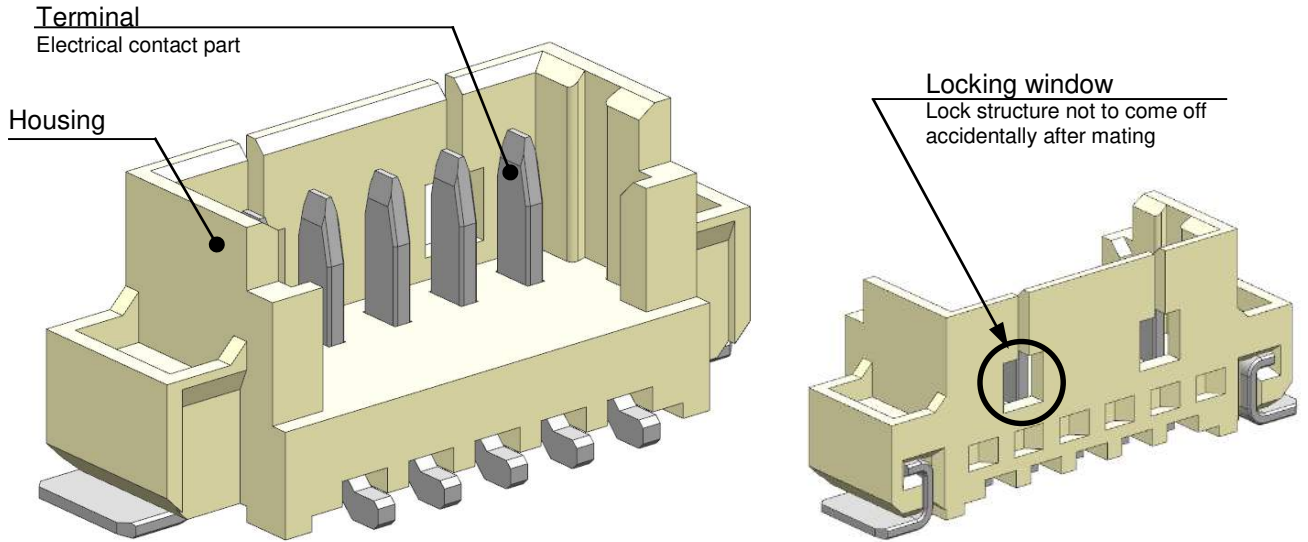

Fig. 3-5 SMT ST type: 53398 series

SMT R/A type: 53261 series

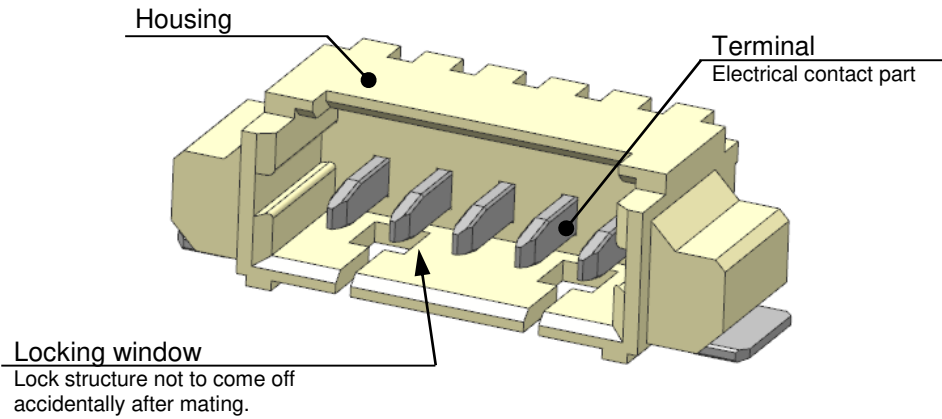

Fig. 3-6 SMT R/A type: 53261 series

REVISE ON PC ONLY		TITLE: PicoBlade 1.25 DIP TYPE & SMT TYPE APPLICATION SPECIFICATION		
A	SEE SHEET 1 OF 58			
REV.	DESCRIPTION	THIS DOCUMENT CONTAINS INFORMATION THAT IS PROPRIETARY TO MOLEX ELECTRONIC TECHNOLOGIES, LLC AND SHOULD NOT BE USED WITHOUT WRITTEN PERMISSION		
DOCUMENT NUMBER 510210000-AS	DOC. TYPE PS	DOC. PART 000	CUSTOMER GENERAL	SHEET 10 OF 58
EN-127(2015-12)				

[4. Confirmation items for crimping wire]

4-1. The appearance before crimping.

Please make sure that there is no deformation of the crimp terminal. If you find that the terminals are tangled, please do not remove them forcibly. Please refer to sales drawing for product form and its dimensions.

4-2. The appearance after crimping.

Confirmation items and crimping failure after crimping are shown as follows. Please refer to crimp specifications for crimp height, and applicable wire specifications, and so on.

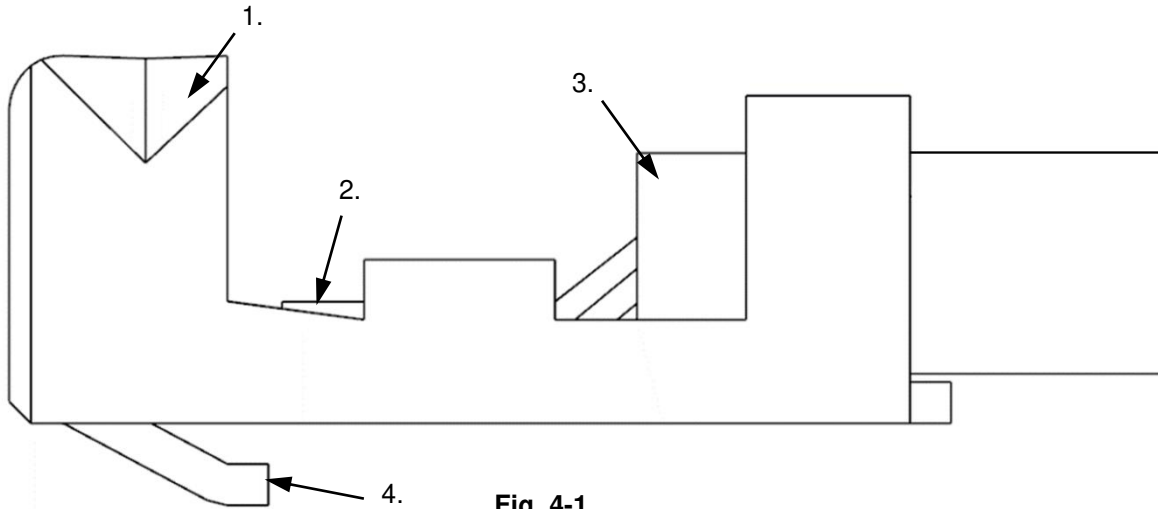

Fig. 4-1

- 1. No visible damage or deformation on contact area.
- 2. All stranded wires do not protrude to the outside of the terminal.
- 3. The insulator part of wire is located in the intermediate position of wire barrel and insulation barrel.
- 4. No damage on terminal lance.
- 5. No damage on appearance. (Dirt / foreign objects)

REVISE ON PC ONLY		TITLE: PicoBlade 1.25 DIP TYPE & SMT TYPE APPLICATION SPECIFICATION			
A	SEE SHEET 1 OF 58				
REV.	DESCRIPTION	THIS DOCUMENT CONTAINS INFORMATION THAT IS PROPRIETARY TO MOLEX ELECTRONIC TECHNOLOGIES, LLC AND SHOULD NOT BE USED WITHOUT WRITTEN PERMISSION			
DOCUMENT NUMBER 510210000-AS		DOC. TYPE PS	DOC. PART 000	CUSTOMER GENERAL	SHEET 11 OF 58
EN-127(2015-12)					

4-3. Crimping failure.

Please be careful of the crimping failure as shown below.
It may affect the insertion to housing and affect a product function.

1. Bend up

It may deteriorate insertion to housing and terminal retention force or cause contact failure.

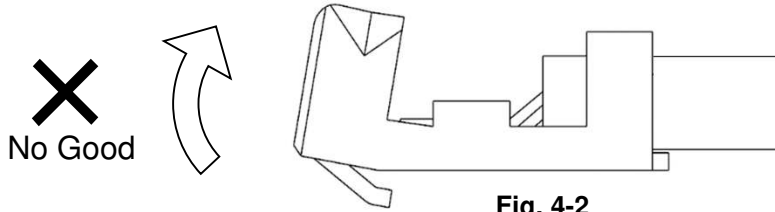

Fig. 4-2

2. Bend down

It may deteriorate insertion to housing and terminal retention force or cause contact failure.

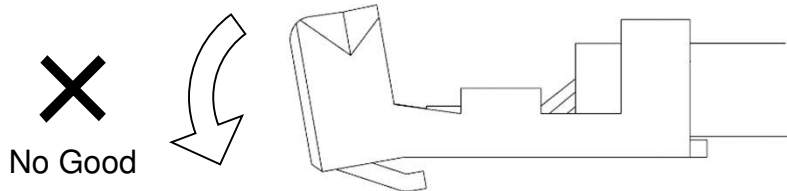

Fig. 4-3

3. Twist

It may deteriorate insertion to housing and terminal retention force or cause contact failure.

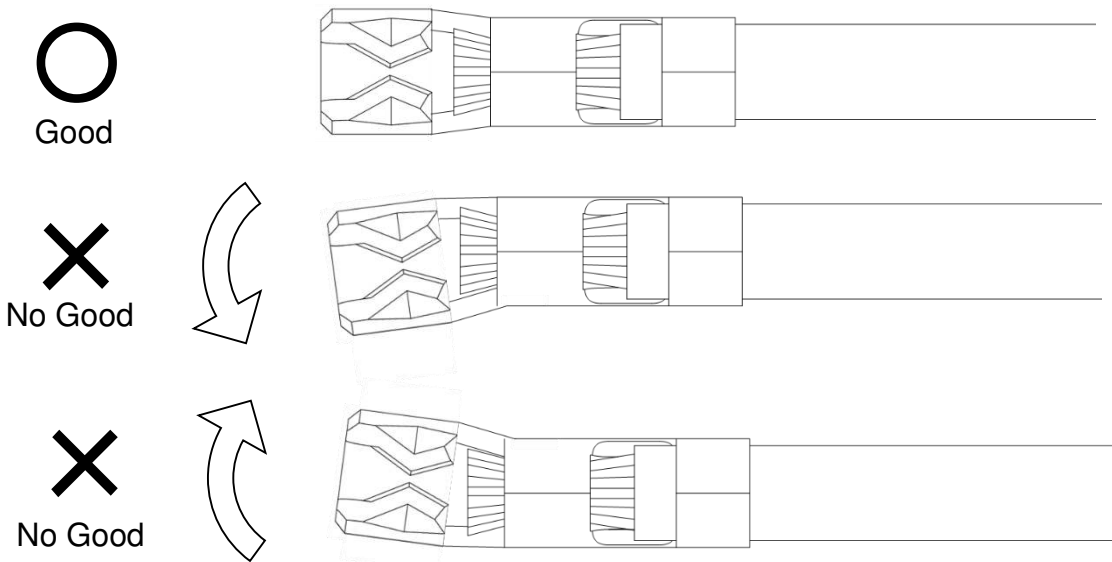

Fig. 4-4

REVISE ON PC ONLY		TITLE:		
A	SEE SHEET 1 OF 58	PicoBlade 1.25 DIP TYPE & SMT TYPE APPLICATION SPECIFICATION		
REV.	DESCRIPTION	THIS DOCUMENT CONTAINS INFORMATION THAT IS PROPRIETARY TO MOLEX ELECTRONIC TECHNOLOGIES, LLC AND SHOULD NOT BE USED WITHOUT WRITTEN PERMISSION		
DOCUMENT NUMBER 510210000-AS		DOC. TYPE PS	DOC. PART 000	CUSTOMER GENERAL
				SHEET 12 OF 58
EN-127(2015-12)				

4. Rolling

It may deteriorate insertion to housing and terminal retention force or cause contact failure.

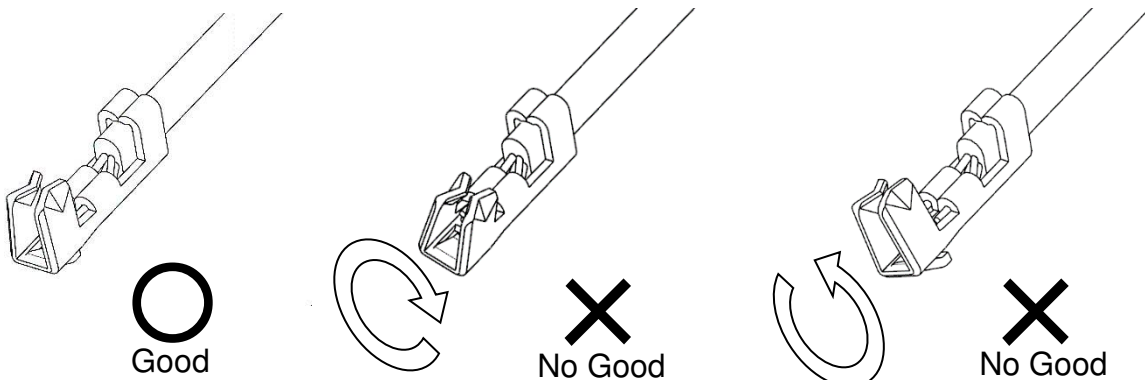

Fig. 4-5

5. Crush and deformation of contact area and contact box

It may deteriorate insertion to housing and terminal retention force or cause contact failure.

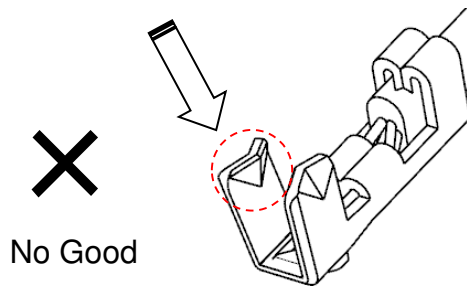

Fig. 4-6

6. Stranded wires are not inside the conductor barrel

It may deteriorate insertion to housing and cause contact failure.

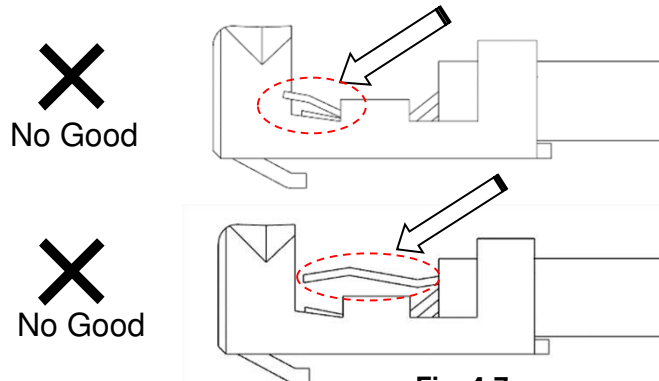

Fig. 4-7

REVISE ON PC ONLY		TITLE:		
A	SEE SHEET 1 OF 58	PicoBlade 1.25 DIP TYPE & SMT TYPE APPLICATION SPECIFICATION		
REV.	DESCRIPTION	THIS DOCUMENT CONTAINS INFORMATION THAT IS PROPRIETARY TO MOLEX ELECTRONIC TECHNOLOGIES, LLC AND SHOULD NOT BE USED WITHOUT WRITTEN PERMISSION		
DOCUMENT NUMBER 510210000-AS		DOC. TYPE PS	DOC. PART 000	CUSTOMER GENERAL
				SHEET 13 OF 58
EN-127(2015-12)				

7. Crimping position: Too front

It may cause breaking of wire, deterioration of wire crimping strength and disconnection by crimping insulator.

X
No Good

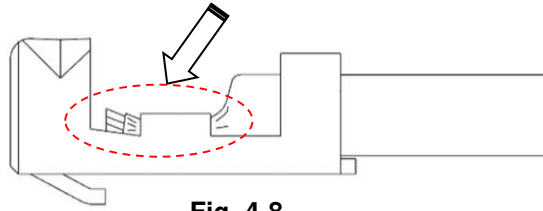
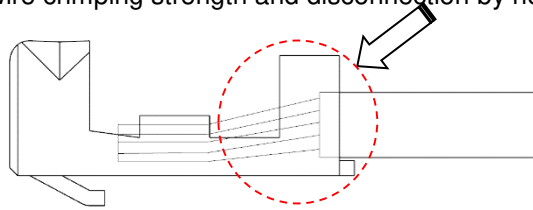

Fig. 4-8

8. Crimping position: Too behind

It may cause deterioration of wire crimping strength and disconnection by not having enough crimping margin.

X
No Good



As wire insulation is not crimped completely, wire insulation falls off easily when wire is pulled.

X
No Good

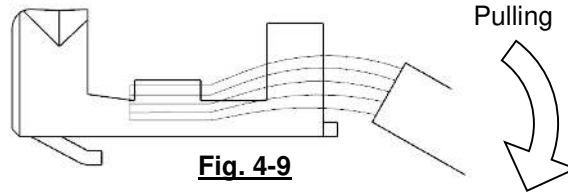
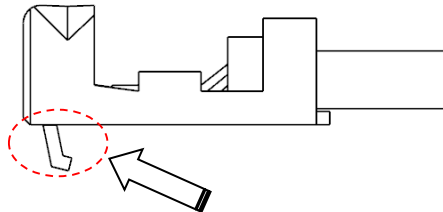

Fig. 4-9

9. Deformation of terminal lance

Locking of the terminal becomes insufficient and causes lowering of the terminal retention force.

X
No Good



X
No Good

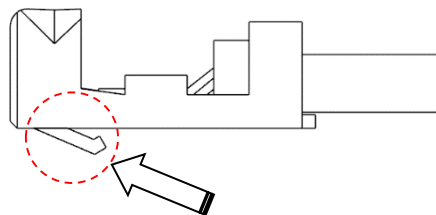

Fig. 4-10

REVISE ON PC ONLY		TITLE: PicoBlade 1.25 DIP TYPE & SMT TYPE APPLICATION SPECIFICATION			
A	SEE SHEET 1 OF 58				
REV.	DESCRIPTION	THIS DOCUMENT CONTAINS INFORMATION THAT IS PROPRIETARY TO MOLEX ELECTRONIC TECHNOLOGIES, LLC AND SHOULD NOT BE USED WITHOUT WRITTEN PERMISSION			
DOCUMENT NUMBER 510210000-AS		DOC. TYPE PS	DOC. PART 000	CUSTOMER GENERAL	SHEET 14 OF 58
EN-127(2015-12)					

[5. Wire bundling and package after crimping]

Please check for damaged terminal and wire insulation, when bundling wires.
 (Recommended bundling position is 30mm from crimped portion. Fig. 5-1)
 Please check for the quantity per packing-box.
 Do not over pack crimped wires in a box as there is risk of damaging terminals

Instruction

- ※When bundling wires, please be careful not to apply excessive force to terminals.
- ※When packing bundled harnesses in package box, please stack product alternately so that no load is applied to connector for a long time. **(Fig.5-2)**
- ※Please lay buffer material on the bottom and top of the package box. **(Fig.5-2)**
 Also, please lay buffer material between bundled wires as necessary, in order to avoid applying force to connector for a long time by stacking the wires.

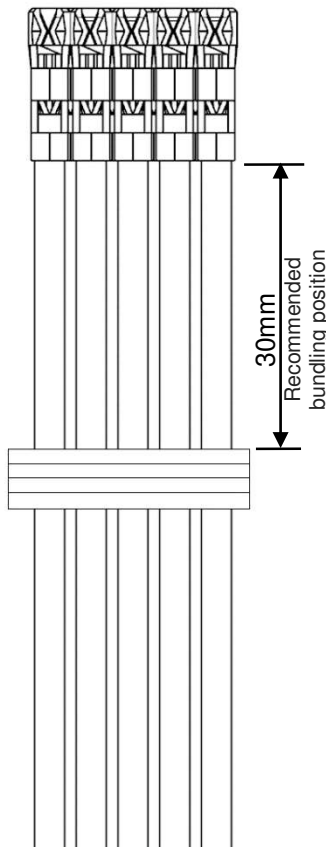

Fig. 5-1

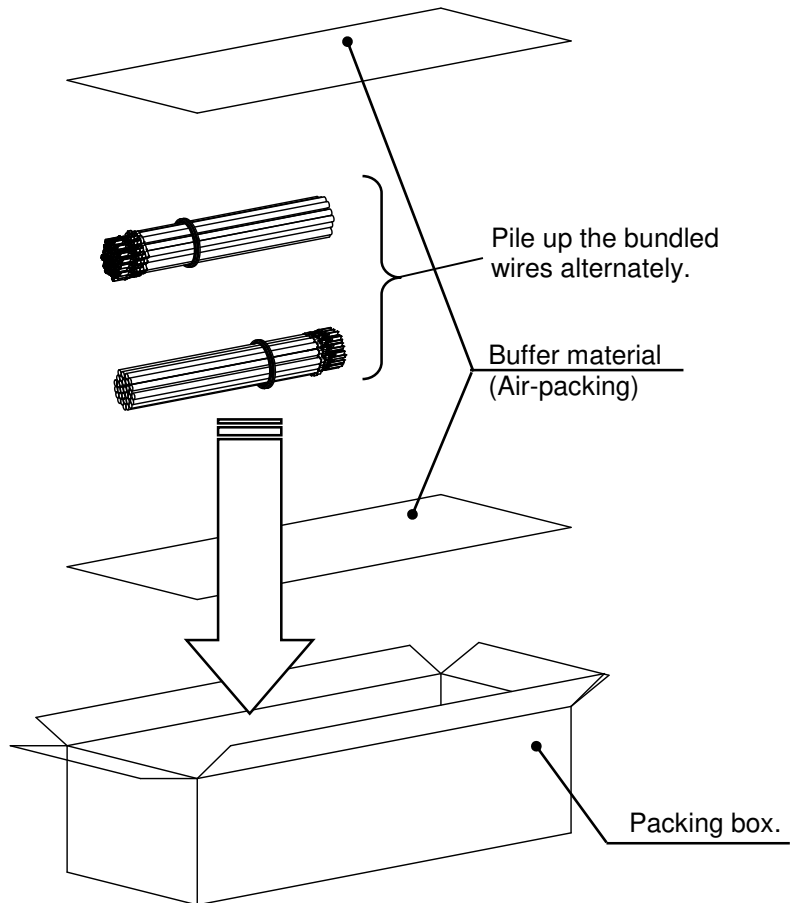

Fig. 5-2

REVISE ON PC ONLY		TITLE: PicoBlade 1.25 DIP TYPE & SMT TYPE APPLICATION SPECIFICATION			
A	SEE SHEET 1 OF 58				
REV.	DESCRIPTION	THIS DOCUMENT CONTAINS INFORMATION THAT IS PROPRIETARY TO MOLEX ELECTRONIC TECHNOLOGIES, LLC AND SHOULD NOT BE USED WITHOUT WRITTEN PERMISSION			
DOCUMENT NUMBER 510210000-AS		DOC. TYPE PS	DOC. PART 000	CUSTOMER GENERAL	SHEET 15 OF 58
EN-127(2015-12)					

[6. Harness processing (crimping wire insertion method in Receptacle housing)]

Insertion procedure and instructions (※) of the crimping wire are shown as follows:

6-1. Insertion of crimping wire

1. Hold receptacle housing by pinching right and left side softly.
- ※ Don't hold on mold lance when you insert crimping wire to receptacle housing. (Fig.6-1)
It makes difficult to insert, or connector may be deformed or damaged.

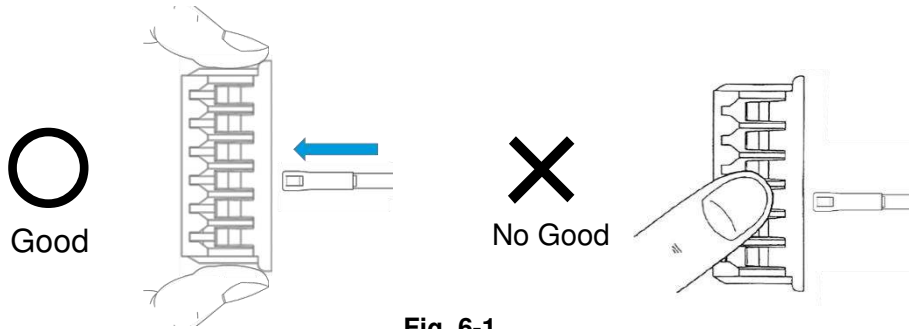

Fig. 6-1

2. Please hold the cable at about 10mm away from the crimped portion with fingers lightly.
- ※ If you hold the wire at a position distant from terminal, wires will be easily bent and it may be difficult to insert.
- ※ Optimum distance to hold wire depends on wire gauge, UL, etc. Please confirm with the wire that you chose before using.
3. Hold wire and have terminal lance part toward receptacle housing, then insert terminal slowly and straightly till the tip of terminal touches housing (with force of around 2~4N). (Fig.6-2)

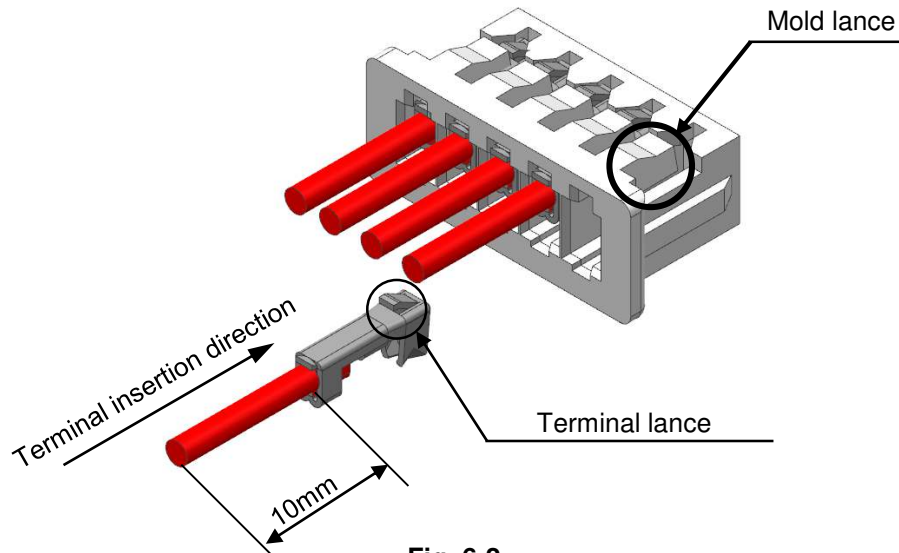
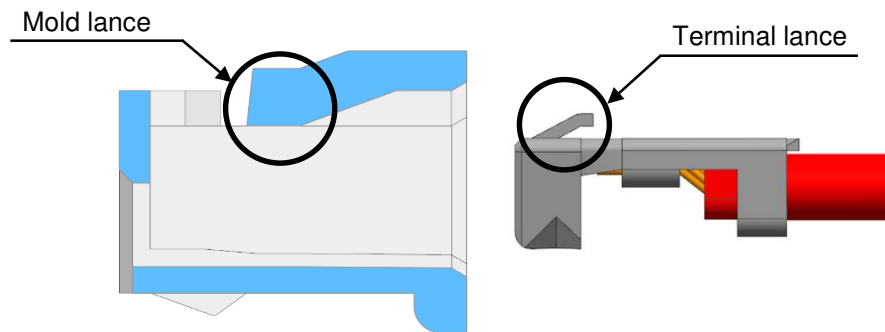

Fig. 6-2

REVISE ON PC ONLY		TITLE: PicoBlade 1.25 DIP TYPE & SMT TYPE APPLICATION SPECIFICATION			
A	SEE SHEET 1 OF 58				
REV.	DESCRIPTION	THIS DOCUMENT CONTAINS INFORMATION THAT IS PROPRIETARY TO MOLEX ELECTRONIC TECHNOLOGIES, LLC AND SHOULD NOT BE USED WITHOUT WRITTEN PERMISSION			
DOCUMENT NUMBER 510210000-AS		DOC. TYPE PS	DOC. PART 000	CUSTOMER GENERAL	SHEET 16 OF 58
EN-127(2015-12)					

Instruction

- ※If crimping height and width are too large, there is a problem for the terminal insertion.
Please follow the instructed crimping height. (Please refer to crimping specifications for detail)
- ※Please keep correct insertion direction. (Fig.6-3)
Please be careful that the terminal is not upside down, not having an angle over 5°, or not rotated against receptacle housing. These may cause terminal deformation or damage to receptacle housing. (Fig.6-4)
- ※If you feel unusual such as hooking during the insertion, please stop insertion and confirm if there is no damage of terminal or receptacle housing.
If the damage is found, do not use the terminal and receptacle housing.



○
Good

Fig.6-3 Correct insertion direction

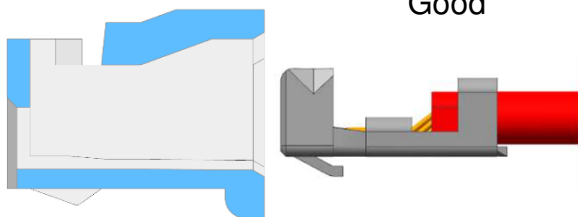

×
No Good

Upside down direction

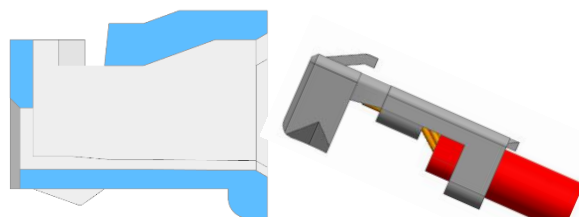

×
No Good

Oblique direction

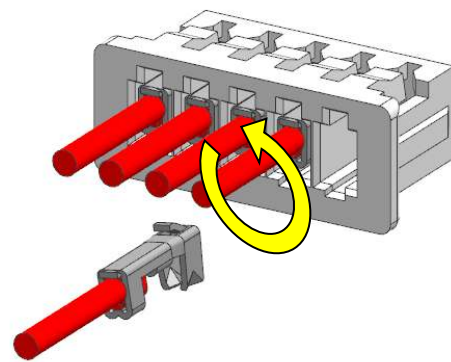

×
No Good

Rotated (Beyond 5°)

Fig.6-4 Inappropriate insertion direction

REVISE ON PC ONLY

A

SEE SHEET 1 OF 58

TITLE:

**PicoBlade 1.25 DIP TYPE & SMT TYPE
APPLICATION SPECIFICATION**

REV.

DESCRIPTION

THIS DOCUMENT CONTAINS INFORMATION THAT IS PROPRIETARY TO MOLEX ELECTRONIC TECHNOLOGIES, LLC AND SHOULD NOT BE USED WITHOUT WRITTEN PERMISSION

DOCUMENT NUMBER
510210000-AS

DOC. TYPE
PS

DOC. PART
000

CUSTOMER
GENERAL

SHEET
17 OF 58

4. After inserting the terminal, please confirm if terminals are not pulled out from receptacle housing by pulling wires lightly (with about 100g force, in order not to damage connector.)
5. After inserting all terminals, please confirm the position of mold lance and terminal lance. If they are inserted correctly, terminal lance is locked by mold lance. (**Fig.6-5, 6-6**)

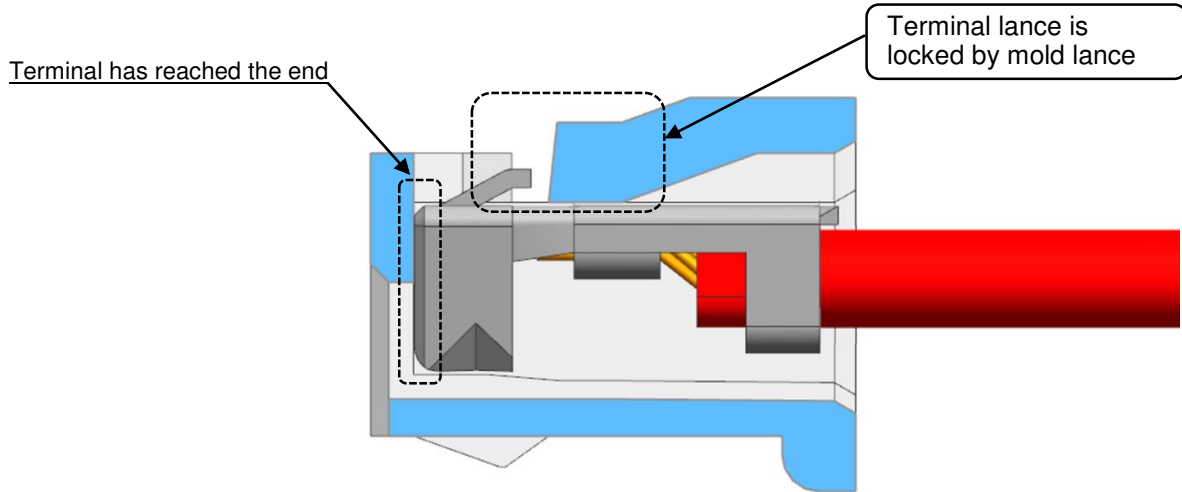

Good

Fig.6-5 Case of correct insertion

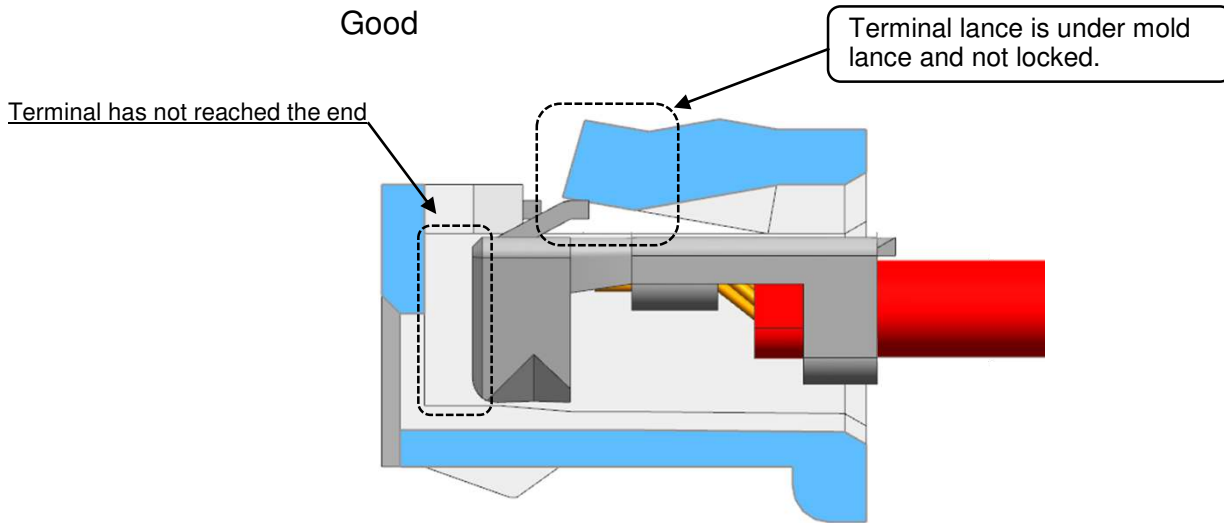

No Good

Fig.6-6 Case of incomplete insertion

REVISE ON PC ONLY		TITLE: PicoBlade 1.25 DIP TYPE & SMT TYPE APPLICATION SPECIFICATION			
A	SEE SHEET 1 OF 58				
REV.	DESCRIPTION	THIS DOCUMENT CONTAINS INFORMATION THAT IS PROPRIETARY TO MOLEX ELECTRONIC TECHNOLOGIES, LLC AND SHOULD NOT BE USED WITHOUT WRITTEN PERMISSION			
DOCUMENT NUMBER 510210000-AS		DOC. TYPE PS	DOC. PART 000	CUSTOMER GENERAL	SHEET 18 OF 58
EN-127(2015-12)					

Instruction

※If terminal is inserted incompletely, terminal lance is not locked with mold lance and terminal is not retained.

※In the case of incomplete insertion (see Fig.6-6), mold lance is deformed. Mold lance kept in such condition is deformed and not go back to correct position, and retention force may decrease even if terminal is re-inserted in to housing. In this case, please replace housing to new one.

6. When checking harness after processing, please avoid bending wire excessively or with tension. That might cause contact failure because force was added to terminal crimping part or receptacle housing lance part.

7. When having a conduction check, do not attach anything besides applicable mating connector. That might cause contact failure because of transformation of terminal etc.

REVISE ON PC ONLY		TITLE: PicoBlade 1.25 DIP TYPE & SMT TYPE APPLICATION SPECIFICATION			
A	SEE SHEET 1 OF 58				
REV.	DESCRIPTION	THIS DOCUMENT CONTAINS INFORMATION THAT IS PROPRIETARY TO MOLEX ELECTRONIC TECHNOLOGIES, LLC AND SHOULD NOT BE USED WITHOUT WRITTEN PERMISSION			
DOCUMENT NUMBER 510210000-AS		DOC. TYPE PS	DOC. PART 000	CUSTOMER GENERAL	SHEET 19 OF 58
EN-127(2015-12)					

6-2. Repair of crimp terminal

When you withdraw the crimp terminal inserted once, please use jig 57072-6000 to raise mold lance. However, mold lance is deformed by being raised. As strength of the deformed lance decreases extremely, the terminal might come off easily from housing even if you insert it again.

Therefore, please be sure to change the receptacle housing to a new one when you repair crimp terminal.

Also, please use an appropriate magnifying glass and repair with caution.

※Please avoid pulling off terminal by force.

※When repairing, please be careful not to deform or scratch terminal lance.

※When you use jig 57072-6000, please refer to instruction manual for jig.

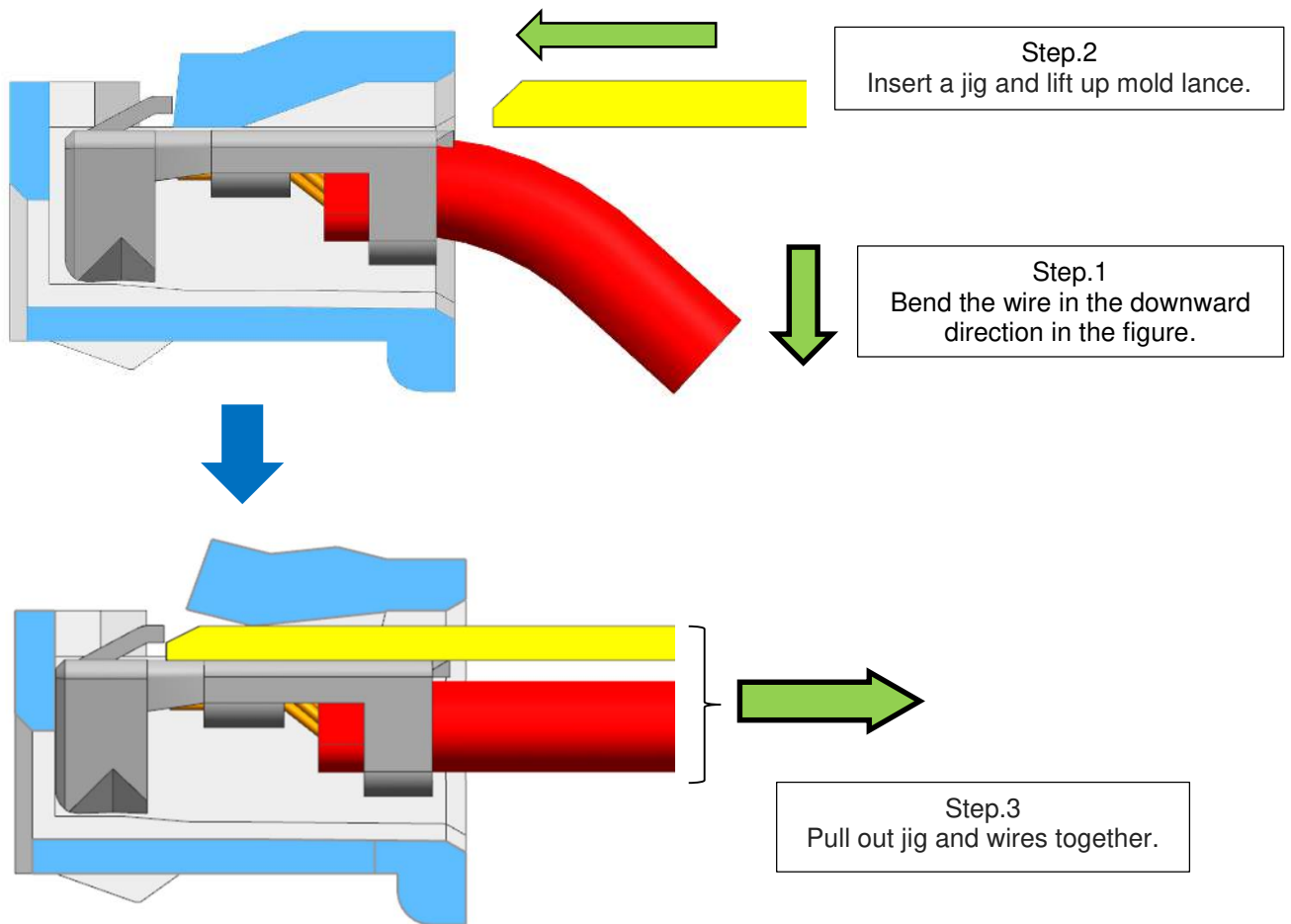

Fig.6-7

REVISE ON PC ONLY		TITLE: PicoBlade 1.25 DIP TYPE & SMT TYPE APPLICATION SPECIFICATION			
A	SEE SHEET 1 OF 58				
REV.	DESCRIPTION	THIS DOCUMENT CONTAINS INFORMATION THAT IS PROPRIETARY TO MOLEX ELECTRONIC TECHNOLOGIES, LLC AND SHOULD NOT BE USED WITHOUT WRITTEN PERMISSION			
DOCUMENT NUMBER 510210000-AS		DOC. TYPE PS	DOC. PART 000	CUSTOMER GENERAL	SHEET 20 OF 58
EN-127(2015-12)					

[7. Banding of harness]

When banding harnessed products, please be careful with the following point.

1. Please bundle the wires at more than 50mm away from connector and uniformize the force applied to each wire. **(Fig.7-1)**
2. As for the harness, please do not apply force to only one wire (or a few particular wires). **(Fig.7-2)**

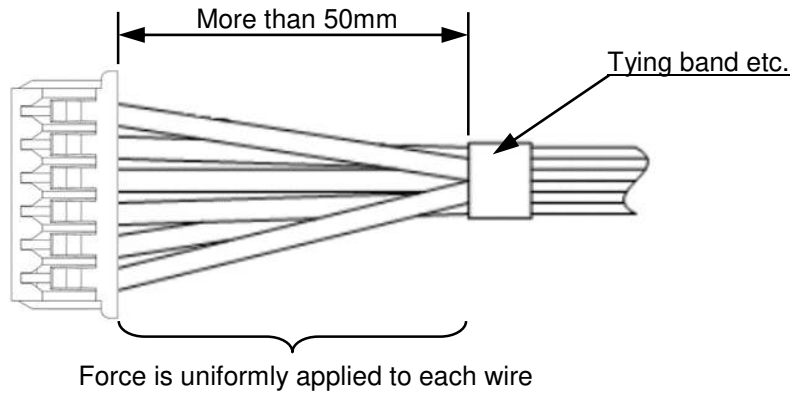

○
Good

Fig.7-1 Properly harnessed state

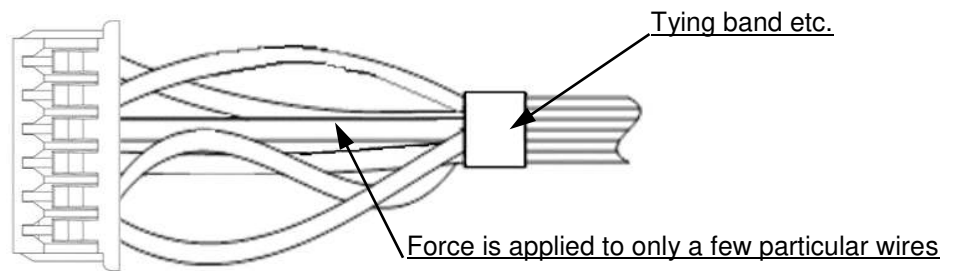

✗
No Good

Fig.7-2 Inappropriately harnessed state

Instruction

- ※When harness is tangled with each other, please do not pull them by force. That might cause damage to connector because extreme force is applied to terminal and it may come off from connector.
- ※Please do not drop the product or hit it against other objects.

REVISE ON PC ONLY		TITLE: PicoBlade 1.25 DIP TYPE & SMT TYPE APPLICATION SPECIFICATION			
A	SEE SHEET 1 OF 58				
REV.	DESCRIPTION	THIS DOCUMENT CONTAINS INFORMATION THAT IS PROPRIETARY TO MOLEX ELECTRONIC TECHNOLOGIES, LLC AND SHOULD NOT BE USED WITHOUT WRITTEN PERMISSION			
DOCUMENT NUMBER 510210000-AS		DOC. TYPE PS	DOC. PART 000	CUSTOMER GENERAL	SHEET 21 OF 58
EN-127(2015-12)					

3. When bending wires after harness process, please have wires loose to prevent from applying load to connector directly. (Fig. 7-3, 7-4)

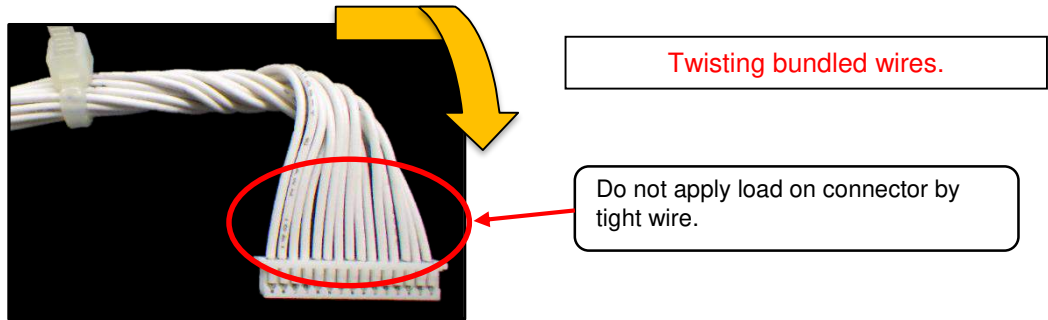

○
Good

Fig. 7-3 Recommended wires bending method (for reference)

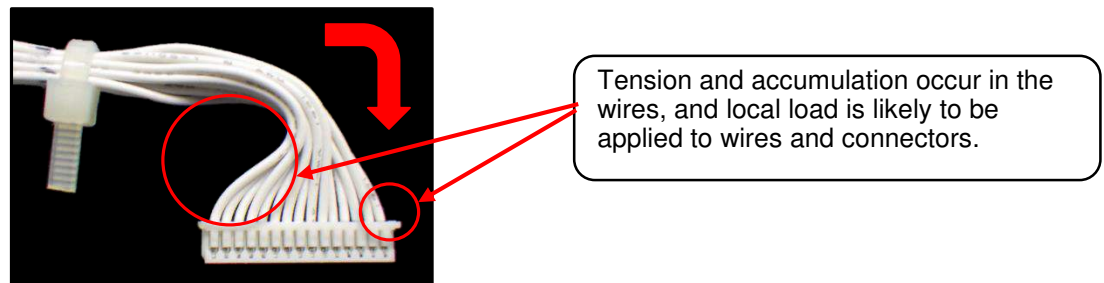

✗
No Good

Bending bundled wires without twisting

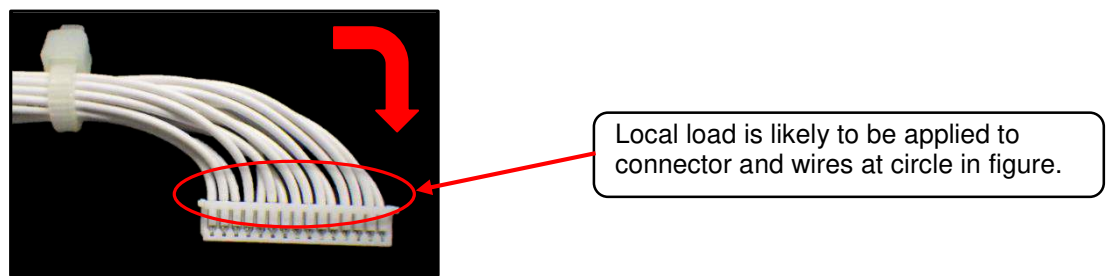

✗
No Good

Bundling wires after bending

Fig. 7-4 Non-recommended wires bending method

REVISE ON PC ONLY		TITLE: PicoBlade 1.25 DIP TYPE & SMT TYPE APPLICATION SPECIFICATION			
A	SEE SHEET 1 OF 58				
REV.	DESCRIPTION	THIS DOCUMENT CONTAINS INFORMATION THAT IS PROPRIETARY TO MOLEX ELECTRONIC TECHNOLOGIES, LLC AND SHOULD NOT BE USED WITHOUT WRITTEN PERMISSION			
DOCUMENT NUMBER 510210000-AS		DOC. TYPE PS	DOC. PART 000	CUSTOMER GENERAL	SHEET 22 OF 58
EN-127(2015-12)					

[8. Recommended packaging of cable harness and assemblies]

The procedure for packing harnessed products is shown below.

1. When bundle the harnessed products, please band about 20 harness in one bunch.

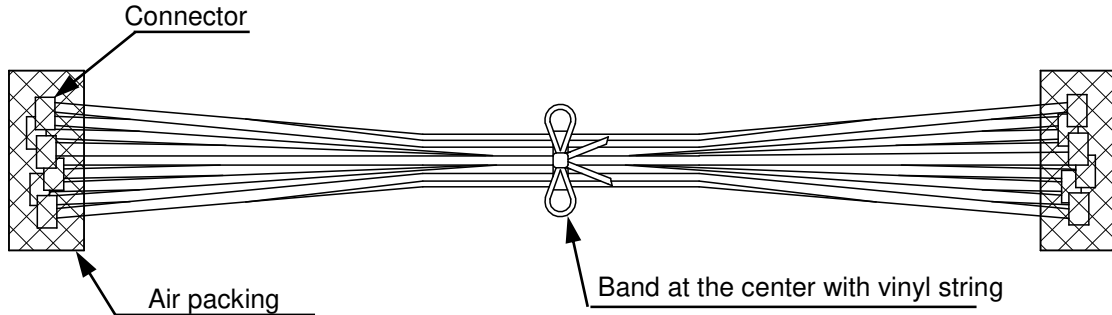

Fig.8-1 A bunch of harness

Instruction

※When bundle the harness, in order to avoid applying excessive force on wires, please do not use anything that fastens tightly such as rubber band. Please band at the center (at one point) with vinyl string. Please protect connector from shock or load by wrapping each bunch of connector with air packing. (Fig.8-1)

REVISE ON PC ONLY		TITLE: PicoBlade 1.25 DIP TYPE & SMT TYPE APPLICATION SPECIFICATION			
A	SEE SHEET 1 OF 58				
REV.	DESCRIPTION	THIS DOCUMENT CONTAINS INFORMATION THAT IS PROPRIETARY TO MOLEX ELECTRONIC TECHNOLOGIES, LLC AND SHOULD NOT BE USED WITHOUT WRITTEN PERMISSION			
DOCUMENT NUMBER 510210000-AS		DOC. TYPE PS	DOC. PART 000	CUSTOMER GENERAL	SHEET 23 OF 58
EN-127(2015-12)					

2. Put banded harness into carton box.

Figure below is one of recommended examples for reference. **(Fig 8-2)**

Please do not apply load due to stacking on connectors, if you pack by different packing method for long harness.

Instruction

※When putting bundled harness in a package box, please avoid applying excessive force to harnesses. **(Fig.8-2 Direction A)**

※Please lay air packing etc. on the bottom of package box. Also, please lay buffer material between bundled harnesses as necessary, in order to avoid applying force to connector for a long time by stacking harnesses. **(Fig.8-2 Direction B)**

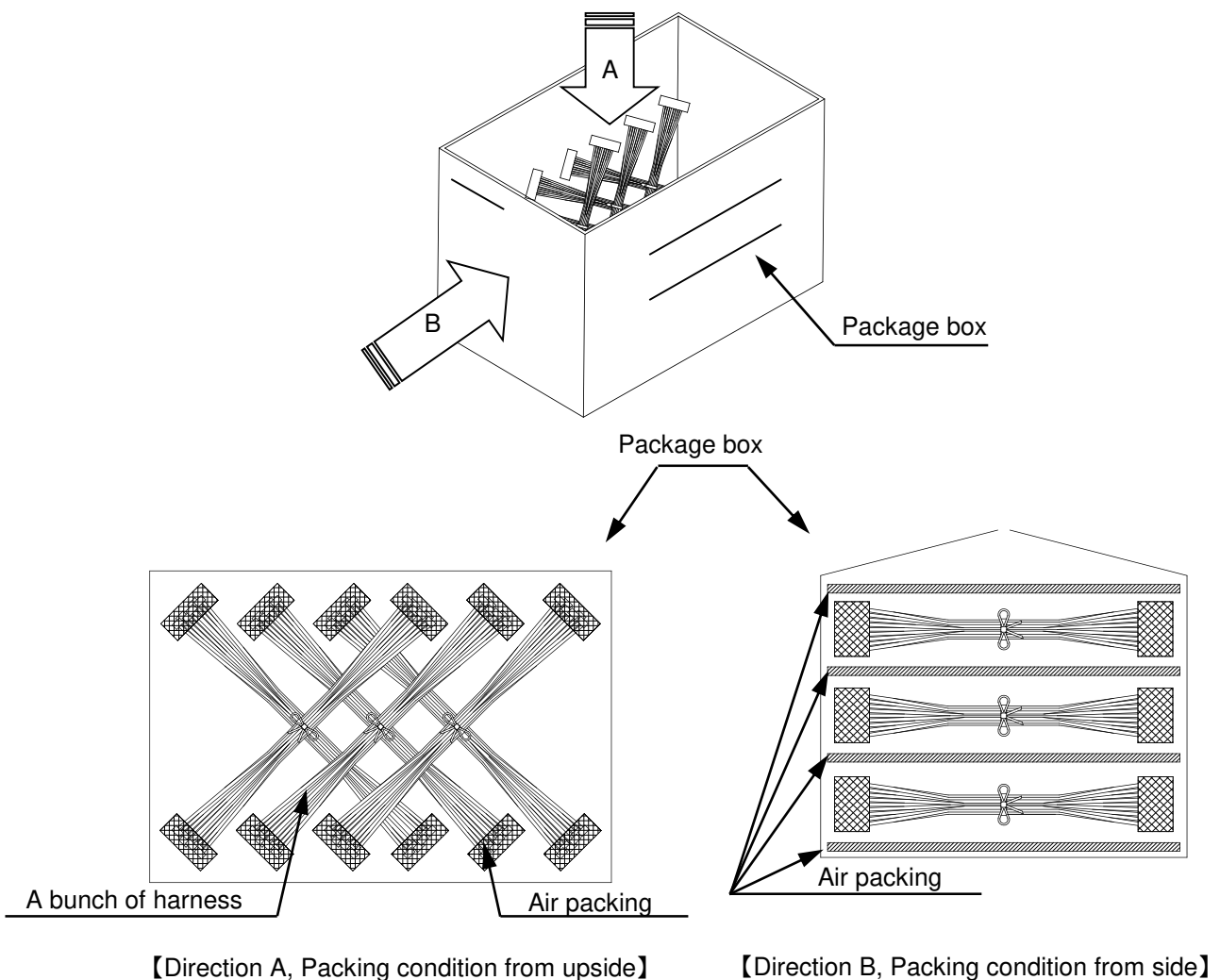

Fig.8-2 Packing condition

REVISE ON PC ONLY		TITLE: PicoBlade 1.25 DIP TYPE & SMT TYPE APPLICATION SPECIFICATION			
A	SEE SHEET 1 OF 58				
REV.	DESCRIPTION	THIS DOCUMENT CONTAINS INFORMATION THAT IS PROPRIETARY TO MOLEX ELECTRONIC TECHNOLOGIES, LLC AND SHOULD NOT BE USED WITHOUT WRITTEN PERMISSION			
DOCUMENT NUMBER 510210000-AS		DOC. TYPE PS	DOC. PART 000	CUSTOMER GENERAL	SHEET 24 OF 58

[9. Instructions of mounting on P.C.B.]

1. Confirm if connector, PCB and metal mask (SMT type) meet the Molex sales drawing.
2. When mounting DIP type connector, please load connector into PCB straight down.
Do not tilt or squeeze the connector in wrong directions.

Instruction for DIP type connector

- ※When touching the connector, be sure not to touch the contacts.
- ※Load the solder tails straightly into the PCB.
- ※Do not apply force in such directions that would damage the solder tails.
- ※In case you push the solder tails in such directions, the pin deformations and pin fallout would occur and damage the connector.
- ※In case the insertion is not smooth, please confirm if there is HS'G deformation or PCB dimensions out of spec and change it to a good part.
- ※It could damage the PCB or the HS'G when inserted robustly.

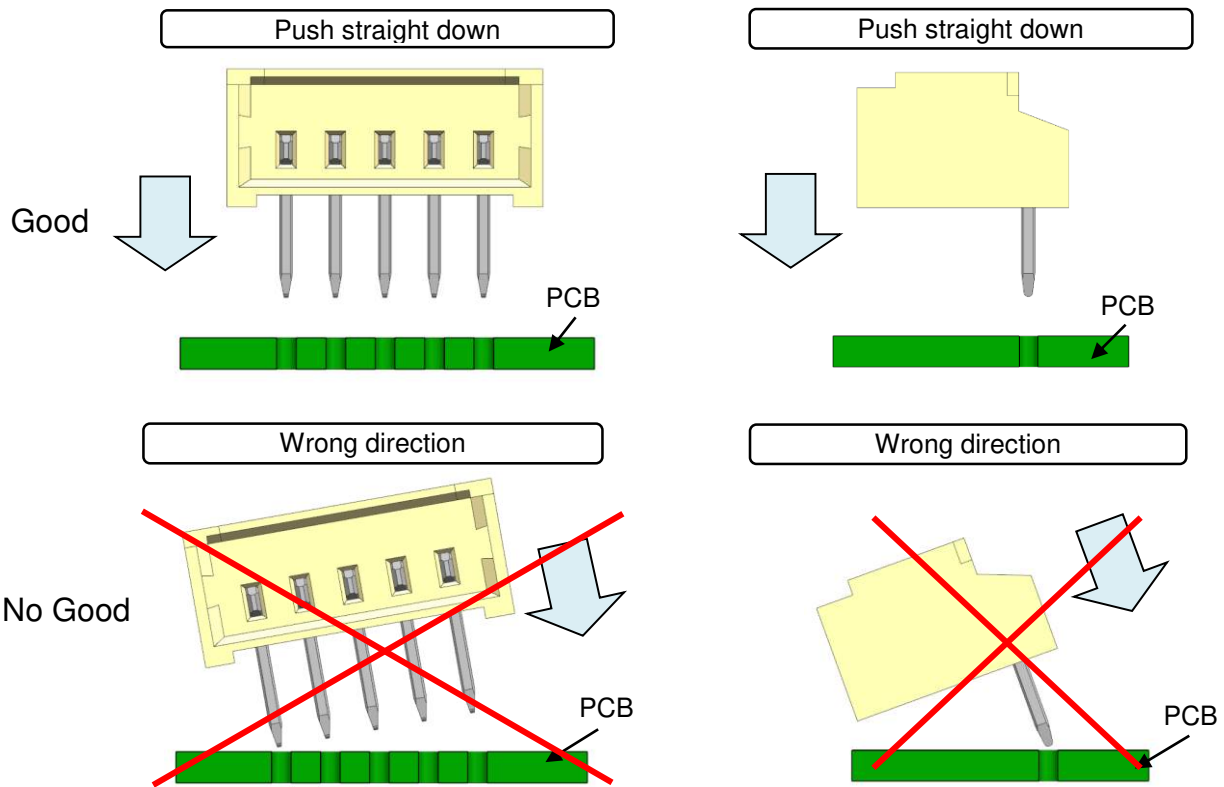

REVISE ON PC ONLY		TITLE: PicoBlade 1.25 DIP TYPE & SMT TYPE APPLICATION SPECIFICATION			
A	SEE SHEET 1 OF 58				
REV.	DESCRIPTION	THIS DOCUMENT CONTAINS INFORMATION THAT IS PROPRIETARY TO MOLEX ELECTRONIC TECHNOLOGIES, LLC AND SHOULD NOT BE USED WITHOUT WRITTEN PERMISSION			
DOCUMENT NUMBER 510210000-AS		DOC. TYPE PS	DOC. PART 000	CUSTOMER GENERAL	SHEET 25 OF 58
EN-127(2015-12)					

[10. Instruction when mating with HDR connector]

10-1. Mating process method

Please set mating direction of receptacle housing (harness side) and plug housing (header side), and push both sides of receptacle housing to arrows direction **until both connectors meet each other.**

Please push both sides of receptacle hs'g and insert.

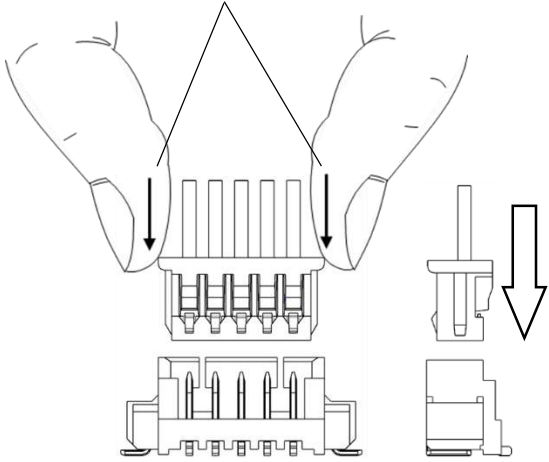

Insert straight
(ST,RA type)

Fig. 10-1

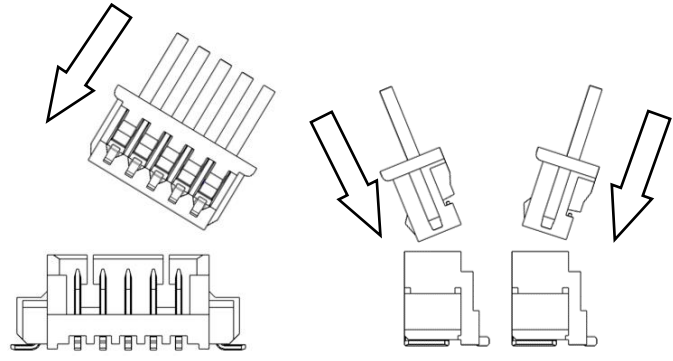

No Good

Insert with an angle
(ST,RA type)

Fig. 10-2

Instruction

※If you cannot insert smoothly, please insert again after confirming if there is no transformation of terminal and receptacle housing etc.

REVISE ON PC ONLY		TITLE: PicoBlade 1.25 DIP TYPE & SMT TYPE APPLICATION SPECIFICATION			
A	SEE SHEET 1 OF 58				
REV.	DESCRIPTION	THIS DOCUMENT CONTAINS INFORMATION THAT IS PROPRIETARY TO MOLEX ELECTRONIC TECHNOLOGIES, LLC AND SHOULD NOT BE USED WITHOUT WRITTEN PERMISSION			
DOCUMENT NUMBER 510210000-AS		DOC. TYPE PS	DOC. PART 000	CUSTOMER GENERAL	SHEET 26 OF 58
EN-127(2015-12)					

10-2. Recommended un-mating method

Please hold wires all together lightly and hold edge of receptacle housing by fingertips, then withdraw it slowly, axially and straightly. Please avoid to withdraw them roughly or with an angle. That might cause damage to connector.

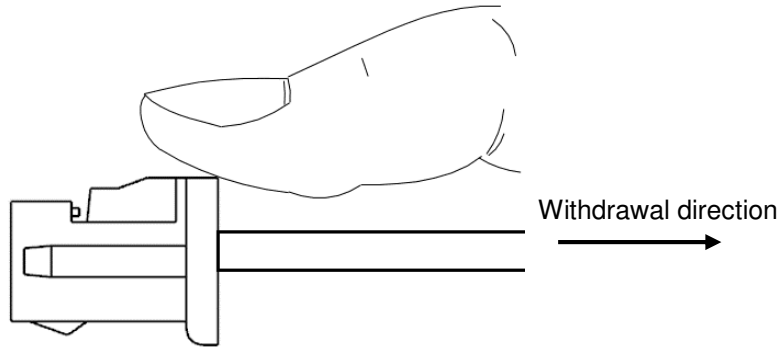

Fig. 10-3

Instruction

※Please do not withdraw with holding only a few particular wires. As excessive force is applied to particular terminals, connector might be damaged or terminal might come off.

10-3. Wiring after mating

Instruction

- ※If you plan on pulling around wires inside machine, please take measures to prevent force from applying to connectors directly, such as allowing wires to have enough flexibility. **(Fig. 10-4)**
- ※When pulling wires around inside machine, please do not use under the condition that wires are bent excessively or tension is added. That might be reason for terminal to be pulled out because force is added to terminal crimping portion or terminal insertion portion of receptacle by wire tension. Especially, please prevent force from being applied to only a few particular wire. **(Fig. 10-5)**
- ※If force is added to one particular wire, wire(crimp terminal) might be pulled off.
- ※Wire routing inside customer's device needs to avoid excessive stress. Please avoid pulling them toward more than 2 directions. **(Fig. 10-6)**
- ※If you plan on special wiring inside customer's device, please contact us before using. **(Fig10-5/10-6 etc.)**

REVISE ON PC ONLY		TITLE: PicoBlade 1.25 DIP TYPE & SMT TYPE APPLICATION SPECIFICATION			
A	SEE SHEET 1 OF 58				
REV.	DESCRIPTION	THIS DOCUMENT CONTAINS INFORMATION THAT IS PROPRIETARY TO MOLEX ELECTRONIC TECHNOLOGIES, LLC AND SHOULD NOT BE USED WITHOUT WRITTEN PERMISSION			
DOCUMENT NUMBER 510210000-AS		DOC. TYPE PS	DOC. PART 000	CUSTOMER GENERAL	SHEET 27 OF 58
EN-127(2015-12)					

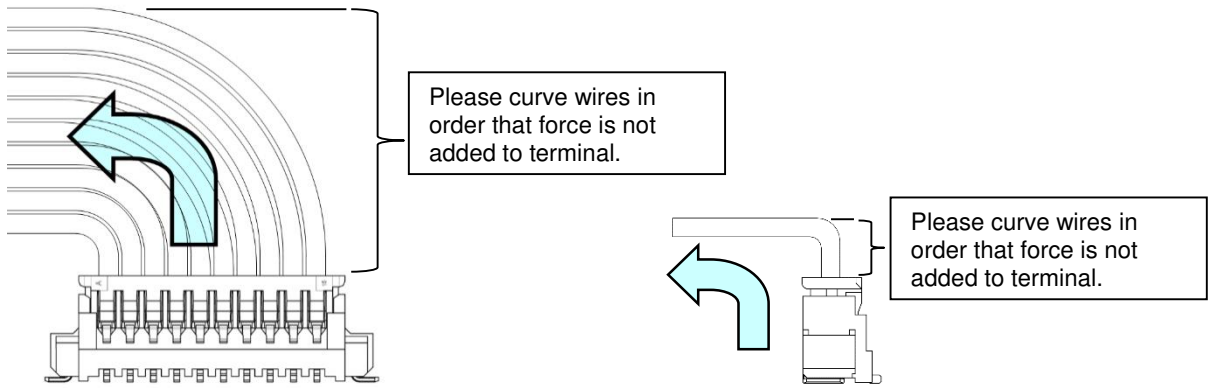

Good

Fig. 10-4 Condition wires are curved

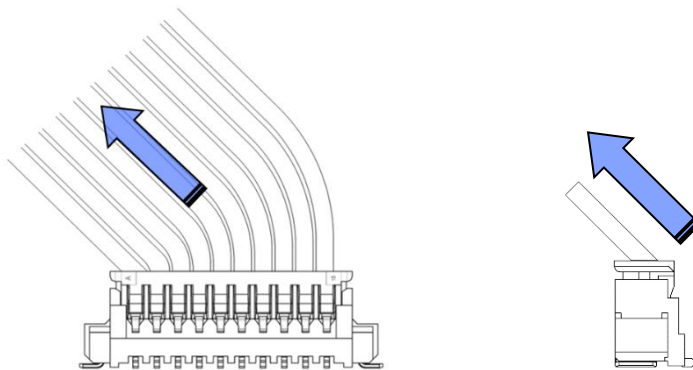

No Good

Fig. 10-5 Condition wires are bent excessively or tension is added

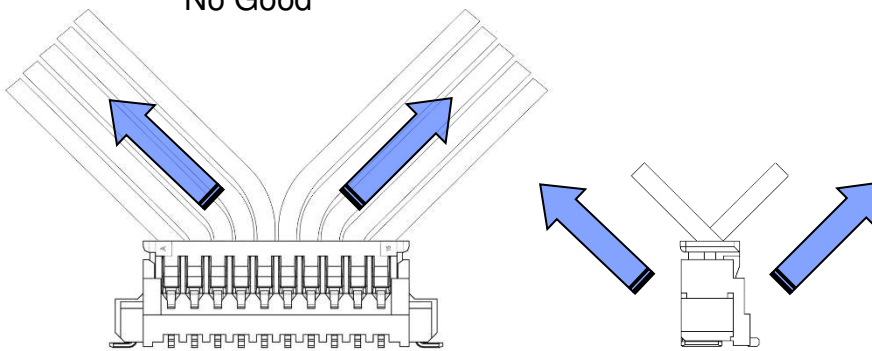

No Good

Fig. 10-6 Wiring toward more than 2 direction.

REVISE ON PC ONLY

A

SEE SHEET 1 OF 58

TITLE:

**PicoBlade 1.25 DIP TYPE & SMT TYPE
APPLICATION SPECIFICATION**

REV.

DESCRIPTION

THIS DOCUMENT CONTAINS INFORMATION THAT IS PROPRIETARY TO MOLEX ELECTRONIC TECHNOLOGIES, LLC AND SHOULD NOT BE USED WITHOUT WRITTEN PERMISSION

DOCUMENT NUMBER
510210000-AS

DOC. TYPE
PS

DOC. PART
000

CUSTOMER
GENERAL

SHEET
28 OF 58

コネクタ 取扱説明書

PicoBlade 1.25 DIP TYPE & SMT TYPE

【1.適用製品】

	製品名称 Product Name	製品型番 Part Number
ハーネス側	リセプタクル ハウジング RECEPTACLE HOUSING	51021 series
	リセプタクル クリンプ ターミナル RECEPTACLE CRIMP TERMINAL	AWG#28~32 50058 series
		AWG#26~28 50079 series
	適用電線 (※) APPLICABLE WIRE	AWG#26~32 錫めっき付軟銅撚り線
適用圧着機 (※) APPLICABLE CRIMP DIE MODEL No.	57067-3**0	
基板側	ヘッダー アッセンブリ HEADER ASS'Y	ストレート ST TYPE 53047 series
	DIP TYPE	ライトアングル R/A TYPE 53048 series
	ヘッダー アッセンブリ HEADER ASS'Y	ストレート ST TYPE 53398 series
	SMT TYPE	ライトアングル R/A TYPE 53261 series

※ 詳細は弊社圧着仕様書をご参照願います。

—はじめに—

- ・本コネクタを御使用頂く前に必ず御一読頂き十分に理解した上、正しくご使用ください。
- ・本書はいつでも参照できるように、お手元に大切に保管してください。
- ・本書中の表示及びイラストは印刷の為、実物と異なることが御座います。
- ・本書の内容に関しては、予告無しに変更する場合がございます。
- ・本書の内容については、万全を期して作成致しておりますが、万が一御不審な点や誤りなど、お気づきのことが御座いましたら弊社担当まで御連絡ください。

REVISE ON PC ONLY		TITLE:		
A	SEE SHEET 1 OF 58	PicoBlade 1.25 DIP TYPE & SMT TYPE APPLICATION SPECIFICATION		
REV.		DESCRIPTION		
THIS DOCUMENT CONTAINS INFORMATION THAT IS PROPRIETARY TO MOLEX ELECTRONIC TECHNOLOGIES, LLC AND SHOULD NOT BE USED WITHOUT WRITTEN PERMISSION				
DOCUMENT NUMBER 510210000-AS	DOC. TYPE PS	DOC. PART 000	CUSTOMER GENERAL	SHEET 29 OF 58
EN-127(2015-12)				

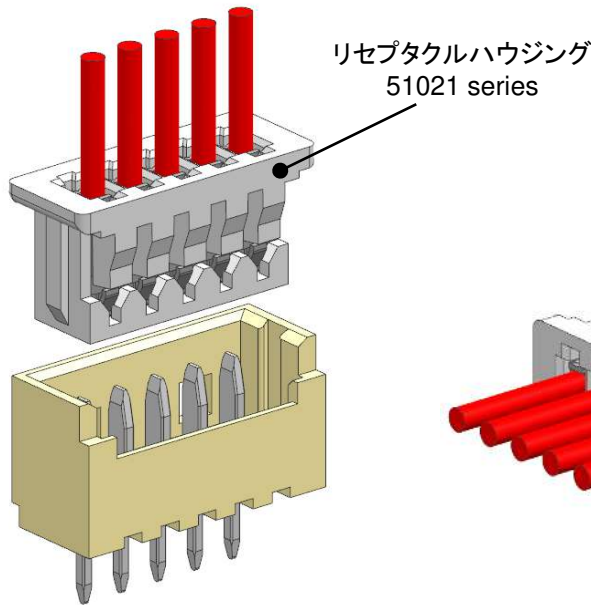

リセプタクルハウジング
51021 series

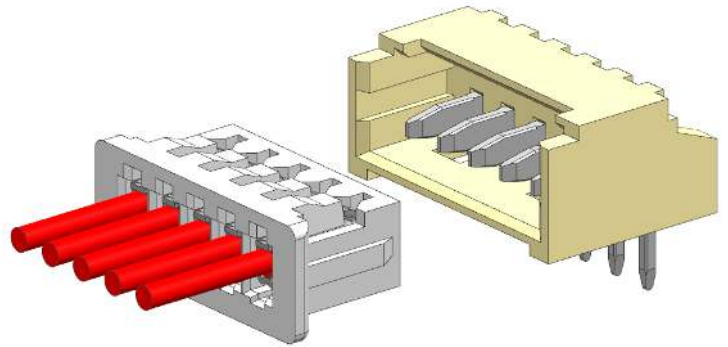

DIP R/A TYPE
53048 series

DIP ST TYPE
53047 series

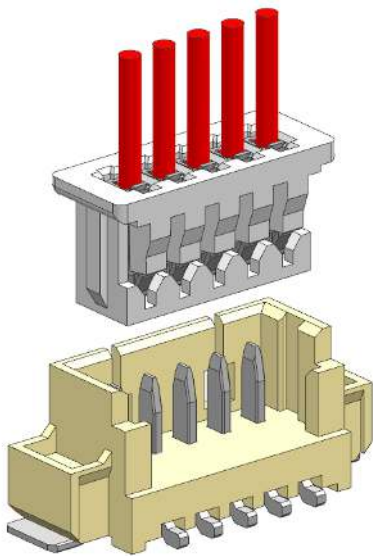

SMT ST TYPE
53398 series

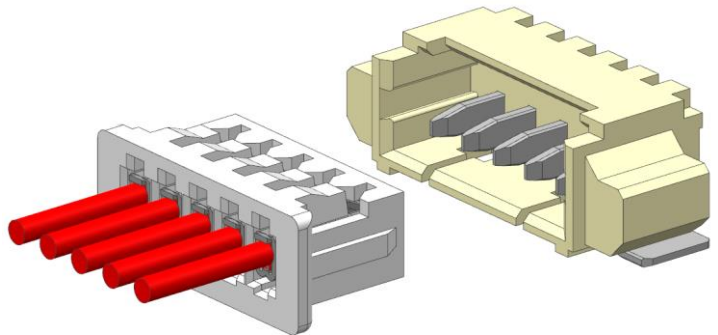

SMT R/A TYPE
53261 series

REVISE ON PC ONLY

A

SEE SHEET 1 OF 58

REV.

DESCRIPTION

TITLE:

**PicoBlade 1.25 DIP TYPE & SMT TYPE
APPLICATION SPECIFICATION**

THIS DOCUMENT CONTAINS INFORMATION THAT IS PROPRIETARY TO MOLEX ELECTRONIC TECHNOLOGIES, LLC AND SHOULD NOT BE USED WITHOUT WRITTEN PERMISSION

DOCUMENT NUMBER
510210000-AS

DOC. TYPE
PS

DOC. PART
000

CUSTOMER
GENERAL

SHEET
30 OF 58

目次

- 1. **適用製品** P-29
- 2. **使用上の注意事項**
 - 2-1. 製品外観について P-32
 - 2-2. 適用電線及び工具について P-32
 - 2-3. ハーネス及び実装作業前の保管について P-32
 - 2-4. ハーネス及び実装作業時に於ける注意事項 P-33~34
 - 2-5. 機器内での使用について P-34
 - 2-6. 定格・性能規格について P-35
 - 2-7. 使用用途 P-35
- 3. **各部の名称及び説明**
 - 3-1. リセプタクル ターミナル(圧着端子)各部の名称及び機能 P-36
 - 3-2. ハーネス各部の名称及び機能 P-37
 - 3-3. ヘッダー(DIP TYPE)各部の名称及び機能 P-38
 - 3-4. ヘッダー(SMT TYPE)各部の名称及び機能 P-39
- 4. **端子圧着加工について**
 - 4-1. 圧着前の外観確認項目 P-40
 - 4-2. 圧着後の外観確認項目 P-40
 - 4-3. 圧着不良について P-41~43
- 5. **圧着後の電線結束および梱包について** P-44
- 6. **リセプタクルハウジングへの圧着端子装着(ハーネス作業)方法**
 - 6-1. 圧着端子装着について P-45~48
 - 6-2. 圧着端子のリペアについて P-49
- 7. **ハーネス結束について** P-50~51
- 8. **ハーネス梱包について** P-52~53
- 9. **基板側コネクタの実装について** P-54
- 10. **嵌合時に於ける注意事項**
 - 10-1. 推奨挿入方法 P-55
 - 10-2. 推奨抜去方法 P-56
 - 10-3. 嵌合後の電線の引き回しについて P-56~57

REVISE ON PC ONLY		TITLE: PicoBlade 1.25 DIP TYPE & SMT TYPE APPLICATION SPECIFICATION			
A	SEE SHEET 1 OF 58				
REV.	DESCRIPTION	THIS DOCUMENT CONTAINS INFORMATION THAT IS PROPRIETARY TO MOLEX ELECTRONIC TECHNOLOGIES, LLC AND SHOULD NOT BE USED WITHOUT WRITTEN PERMISSION			
DOCUMENT NUMBER 510210000-AS		DOC. TYPE PS	DOC. PART 000	CUSTOMER GENERAL	SHEET 31 OF 58
EN-127(2015-12)					

【2. 使用上の注意事項】

2-1. 製品外観について

- ① 本製品のプラスチック部に黒点、気泡等が確認される場合や色合いが異なる場合（経年変化によるハウジングの変色を含む）がありますが、製品性能には影響御座いません。
- ② 本製品のめっき部外観に摺動痕がつく場合が御座いますが、製品性能に影響は御座いません。
- ③ 実装条件によっては、樹脂部の変色や端子めっき部にヨリが発生する場合が御座いますが、製品性能に影響は御座いません。
- ④ 実装機によってコネクタに負荷が加わると変形、破損する場合が御座いますので事前に御確認下さい。

2-2. 適用電線及び工具について

- ① 適用範囲外（電線サイズ、絶縁被覆径など）の電線を御検討される場合、保証の対象外となるため事前に御相談ください。
- ② 弊社指定工具（圧着工具等）以外の御使用における不具合発生に関しては、保証の対象外とさせていただきます。
- ③ コネクタの適用電線は、原則として錫めっき付軟銅撚り線です。その他の電線の使用については別途ご確認ください。

2-3. ハーネス及び実装作業前の保管について

- ① 製品は弊社箱詰め梱包状態にて直射日光の当たらない屋内、年間を通じ常温常湿の条件化での保管をお願いします。材料劣化による破損、変色等の原因となります。
- ② 製品保管の際には外力が掛からないよう保管願います。（納入状態からの詰め替え等）製品の噛み込み、変形等の原因となります。
- ③ 製品の移動時及び搬送時には落下や衝撃による外力を加えないように御注意願います。製品の噛み込み、変形等の原因となります。
- ④ 在庫品は先入れ・先出しを実施して下さい。
- ⑤ 使用前まで弊社実施の梱包形態を維持して下さい。
- ⑥ 推奨保管条件での保管をお願いします。推奨保管条件を超えた場合は外観およびはんだ付け性をご確認の上ご使用下さい。

REVISE ON PC ONLY		TITLE: PicoBlade 1.25 DIP TYPE & SMT TYPE APPLICATION SPECIFICATION			
A	SEE SHEET 1 OF 58				
REV.	DESCRIPTION	THIS DOCUMENT CONTAINS INFORMATION THAT IS PROPRIETARY TO MOLEX ELECTRONIC TECHNOLOGIES, LLC AND SHOULD NOT BE USED WITHOUT WRITTEN PERMISSION			
DOCUMENT NUMBER 510210000-AS		DOC. TYPE PS	DOC. PART 000	CUSTOMER GENERAL	SHEET 32 OF 58
EN-127(2015-12)					

2-4. ハーネス及び実装作業時に於ける注意事項

- ① リセプタクルハウジング及び端子、圧着条件、適用電線が弊社製品図面、圧着仕様書に合致しているかを事前に確認して下さい。（弊社製品図面、圧着仕様書が揃っていない場合は、弊社営業に御要求下さい。）
- ② 本製品を使用する上で端子コンタクト部等に変形、汚れ（異物付着）等のあるものは使用しないで下さい。リセプタクルハウジングへの挿入性や電氣的な性能を満足出来なくなる原因となります。
- ③ 端子には直接手で触れること無きよう、御注意願います。皮脂、汗等の汚れがめっき面に悪影響を与え、電氣的性能が満足出来ない原因となります。
- ④ 圧着前後において端子が絡まっている状態で、無理に端子を引っ張らないで下さい。端子を変形させる原因となります。
- ⑤ リセプタクルハウジング及び端子、加工工程品や加工品（ハーネス等）には、外力を加えないで下さい。製品が変形し、コネクタの性能を満足出来なくなる原因となります。
- ⑥ リセプタクルハウジング及び端子、加工工程品や加工品（ハーネス等）は、ゴミ（埃等）、腐食性物質、腐食性ガス、高温多湿及び直射日光に曝さないで下さい。接触不良や端子の腐食及びハウジングの絶縁性能劣化等の原因となり、機器の動作不良の原因となります。箱等への保管の御配慮をお願い致します。
- ⑦ 本製品及び加工工程品（仕掛品）や加工品（ハーネス等）の梱包及び輸送・保管時にはコネクタに負荷が加わらないようご注意下さい。変形、破損などの原因となり、コネクタの性能不良の原因となります。
- ⑧ ハーネス加工品の電線の引き回しの際、引張りによる力が加わりますと、接点部、結線部（圧着部）やランス部が損傷を受け、接触不良の原因となります。電線の引回し配線をされる場合、コネクタに無理な外力が加わらないように、電線に緩みを持たせ、余裕を持たせる処置をして下さい。
- ⑨ リセプタクルハウジングや端子を故意に変形させないで下さい。製品性能が満足出来ない原因となります。
- ⑩ リセプタクルハウジングの袋詰め梱包を開封した際には当日に使い切るようお願い致します。周囲の雰囲気による過度な乾燥や吸湿等、材料の劣化の原因となる恐れがあります。（使い切ることが無理な場合は、袋の口を再度シーリングし、箱に保管を行う等のご配慮をお願い致します。）
- ⑪ 本コネクタを取り扱う際、金属部などのエッジ部での怪我には御注意願います。
- ⑫ リール端子を取り扱う際、端子やリールの間紙などで手を切るなどの怪我には御注意願います。
- ⑬ 本製品の一般性能確認はリジット基板にて実施しております。フレキシブル基板等の特殊な基板へ実装する場合は事前に実装確認等を行った上でご使用願います。
- ⑭ はんだ実装部の未はんだは、ピン抜け、ピン間ショート、ピン座屈、またコネクタの基板からの外れが懸念されます。従って全てのソルダーテールおよびフィッティングネイル（SMTタイプ）にはんだ付けを行って下さい。

REVISE ON PC ONLY		TITLE: PicoBlade 1.25 DIP TYPE & SMT TYPE APPLICATION SPECIFICATION			
A	SEE SHEET 1 OF 58				
REV.	DESCRIPTION	THIS DOCUMENT CONTAINS INFORMATION THAT IS PROPRIETARY TO MOLEX ELECTRONIC TECHNOLOGIES, LLC AND SHOULD NOT BE USED WITHOUT WRITTEN PERMISSION			
DOCUMENT NUMBER 510210000-AS		DOC. TYPE PS	DOC. PART 000	CUSTOMER GENERAL	SHEET 33 OF 58
EN-127(2015-12)					

- ⑮ 弊社の推奨基板パターン寸法を変更して設計を行なう際は、致命的な不良の原因にもなりますのであらかじめご相談下さい。
- ⑯ コネクタ嵌合状態で基板の持ち運び等コネクタに負荷が掛かる作業は行わないようにして下さい。コネクタ破損等の原因となる場合が御座います。
- ⑰ 基板実装後に基板を直接積み重ねない様に注意して下さい。
- ⑱ 実装後においてははんだごてによる手修正を行う際は、必ず仕様書掲載の条件範囲内で行って下さい。条件を超えて実施した場合、ピン抜け、モールドの変形、溶融等、破損の原因になります。
- ⑲ はんだごてによる手修正を行なう際、過度のはんだやフラックスを使用しないで下さい。はんだ上がりやフラックス上がりにより接触、機能不良に至る場合があります。
- ⑳ 実装条件によっては、樹脂部の変色や端子めっき部にヨリが発生する場合が御座いますが、製品性能に影響はございません。

2-5. 機器内での使用について

- ① 本製品をご使用時に取り付けられた電線・プリント基板の共振や、機器の回転構造や可動部分の動作によりコネクタ嵌合部（接点部）が常に動いてしまう状態での御使用は避けて下さい。接触部の摺動磨耗等による接触不良の原因となります。従って、機器内で電線・プリント基板を固定し共振を抑える等の処置をお願い致します。
- ② コネクタのみで基板を支えることは避け、コネクタ以外での基板固定対策を行って下さい。
- ③ 基板実装前後にピンに触れないで下さい。
- ④ コネクタは極力嵌合軸に沿って挿入抜去を行ってください。斜め挿抜はコネクタ破損等の原因になる場合が有ります。
- ⑤ 嵌合後、コネクタピッチ方向、スパン方向及び回転方向への負荷がかかるような動作またはセットはしないで下さい。コネクタ破壊やはんだクラックを引き起こします。
- ⑥ コネクタ嵌合後の電線の引き回しの際、引張りによる力が加わりますと、接点部、結線部（圧着部）やロック部（端子ロック部）が損傷を受け、接触不良の原因となります。電線の引回し配線をされる場合、コネクタに無理な外力が加わらないように電線に緩みを持たせ余裕を持たせる処置をして下さい。
- ⑦ 治具等を使用し圧着端子を抜いた場合には、ランスが変形し強度が低下し端子を再装着後の端子保持力が低下します。そのため、圧着端子のリペアの際には新しいハウジングを必ずご使用下さい。

REVISE ON PC ONLY		TITLE: PicoBlade 1.25 DIP TYPE & SMT TYPE APPLICATION SPECIFICATION			
A	SEE SHEET 1 OF 58				
REV.	DESCRIPTION	THIS DOCUMENT CONTAINS INFORMATION THAT IS PROPRIETARY TO MOLEX ELECTRONIC TECHNOLOGIES, LLC AND SHOULD NOT BE USED WITHOUT WRITTEN PERMISSION			
DOCUMENT NUMBER 510210000-AS		DOC. TYPE PS	DOC. PART 000	CUSTOMER GENERAL	SHEET 34 OF 58
EN-127(2015-12)					

2-6. 定格・性能規格について

- ① 製品仕様書の定格・規格の範囲内で御使用下さい。
- ② 活電状態の電気回路で、挿入、抜去ができることを前提に作られておりません。スパーク等による危険の発生、性能不良につながりますので、活電状態での挿入、抜去はしないで下さい。
*活電状態：電気を流したまま挿抜を行うこと。
- ③ 実使用時には、その機器に関する設計基準を満足することを確認の上、御使用下さい。
- ④ 予測できないショート（短絡）の発生を防ぐため、コネクタに金属製のパネルや金属片等が接触しないように御配慮願います。
- ⑤ 本製品をご使用時には、1 PIN当りの定格以上の電流を複数の回路に分岐しての使用は避けて下さい。

2-7. 使用用途

- ① 本製品は人命に関わるような状況下で使用される機器、あるいはシステムに用いられることを目的として設計、製造されたものではありません。本製品を医療用、航空宇宙用、原子力等の特殊用途で御使用になる場合は事前に弊社に御確認下さい。
- ② 自動車、船舶等への御使用を検討される場合は事前に弊社に御確認下さい。
(仕様条件によって使用可能であるか検討いたします)
- ③ 室外またはそれに相当する環境下での御使用は避けて下さい。

REVISE ON PC ONLY		TITLE: PicoBlade 1.25 DIP TYPE & SMT TYPE APPLICATION SPECIFICATION			
A	SEE SHEET 1 OF 58				
REV.	DESCRIPTION	THIS DOCUMENT CONTAINS INFORMATION THAT IS PROPRIETARY TO MOLEX ELECTRONIC TECHNOLOGIES, LLC AND SHOULD NOT BE USED WITHOUT WRITTEN PERMISSION			
DOCUMENT NUMBER 510210000-AS		DOC. TYPE PS	DOC. PART 000	CUSTOMER GENERAL	SHEET 35 OF 58
EN-127(2015-12)					

【3. 各部の名称及び説明】

※ 製品形状、寸法及びめっき仕様については弊社製品図面をご参照願います。

3-1. リセプタクルターミナル（圧着端子）各部の名称及び機能：50058, 50079 series.

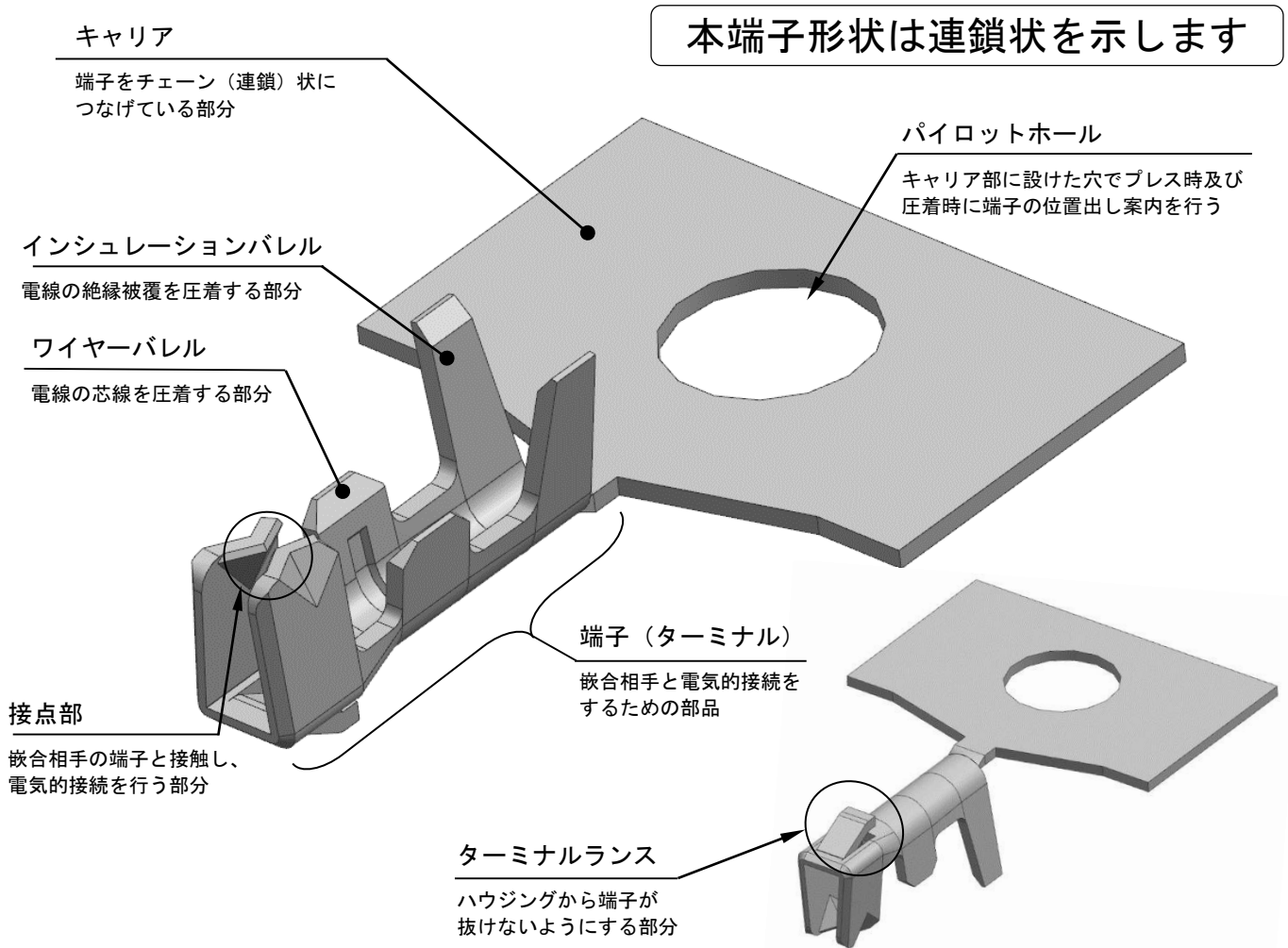

Fig. 3-1 リセプタクルターミナル

REVISE ON PC ONLY		TITLE: PicoBlade 1.25 DIP TYPE & SMT TYPE APPLICATION SPECIFICATION			
A	SEE SHEET 1 OF 58				
REV.	DESCRIPTION	THIS DOCUMENT CONTAINS INFORMATION THAT IS PROPRIETARY TO MOLEX ELECTRONIC TECHNOLOGIES, LLC AND SHOULD NOT BE USED WITHOUT WRITTEN PERMISSION			
DOCUMENT NUMBER 510210000-AS		DOC. TYPE PS	DOC. PART 000	CUSTOMER GENERAL	SHEET 36 OF 58

3-2. ハーネス各部の名称及び機能:51021 series

モールドランス

ハウジングから端子が抜けないように引っ掛ける部分

電線
(AWG#26~#32)

リセプタクル ハウジング
(51021 series)

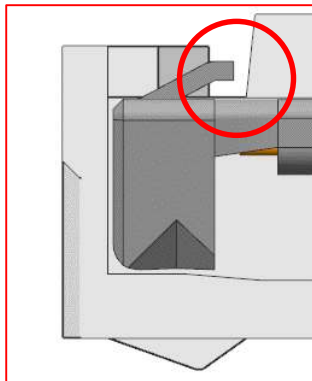

フリクションロック

嵌合後、偶発的に抜けないようにするためのロック機構。

Fig. 3-2 リセプタクルハウジング (ハーネス品)

REVISE ON PC ONLY		TITLE: PicoBlade 1.25 DIP TYPE & SMT TYPE APPLICATION SPECIFICATION			
A	SEE SHEET 1 OF 58				
REV.	DESCRIPTION	THIS DOCUMENT CONTAINS INFORMATION THAT IS PROPRIETARY TO MOLEX ELECTRONIC TECHNOLOGIES, LLC AND SHOULD NOT BE USED WITHOUT WRITTEN PERMISSION			
DOCUMENT NUMBER 510210000-AS		DOC. TYPE PS	DOC. PART 000	CUSTOMER GENERAL	SHEET 37 OF 58

3-3. ヘッダー (DIP type) 各部の名称及び機能

DIP ST type: 53047 series

端子

嵌合相手と電氣的接続をするための部品

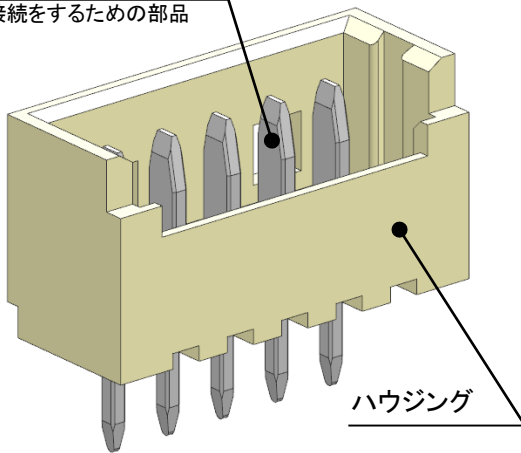

ハウジング

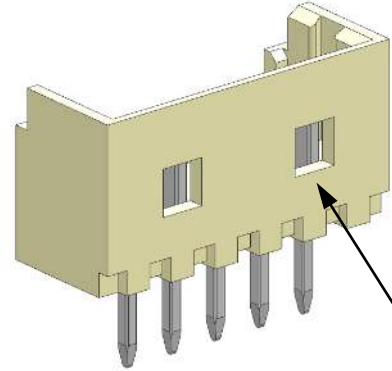

嵌合用ロック窓

嵌合後にヘッダーとハーネス側が抜けないようにフリクションロックに係止する部分

Fig. 3-3 DIP ST type: 53047 series

DIP R/A type: 53048 series

端子

嵌合相手と電氣的接続をするための部品

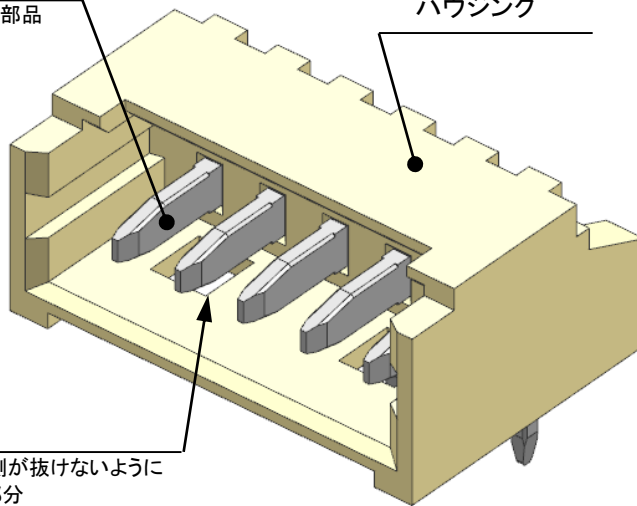

ハウジング

嵌合用ロック窓

嵌合後にヘッダーとハーネス側が抜けないようにフリクションロックに係止する部分

Fig. 3-4 DIP R/A type: 53048 series

REVISE ON PC ONLY		TITLE: PicoBlade 1.25 DIP TYPE & SMT TYPE APPLICATION SPECIFICATION			
A	SEE SHEET 1 OF 58				
REV.	DESCRIPTION	THIS DOCUMENT CONTAINS INFORMATION THAT IS PROPRIETARY TO MOLEX ELECTRONIC TECHNOLOGIES, LLC AND SHOULD NOT BE USED WITHOUT WRITTEN PERMISSION			
DOCUMENT NUMBER 510210000-AS		DOC. TYPE PS	DOC. PART 000	CUSTOMER GENERAL	SHEET 38 OF 58
EN-127(2015-12)					

3-4. ヘッダー (SMT type) 各部の名称及び機能

SMT ST type: 53398 series

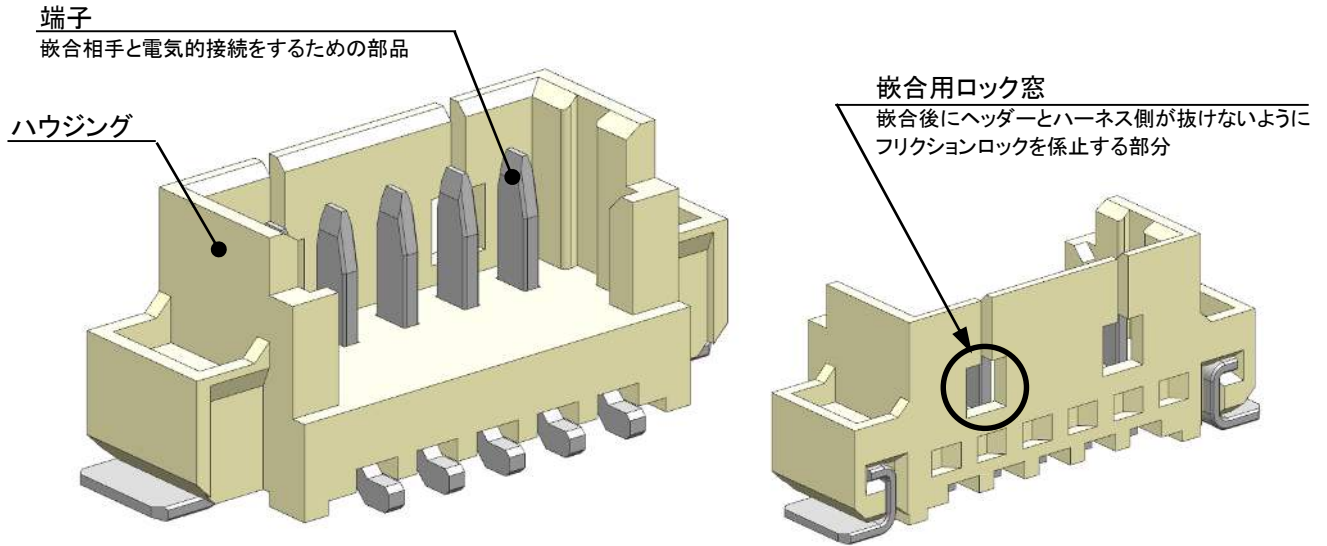

Fig. 3-5 SMT ST type: 53398 series

SMT R/A type: 53261 series

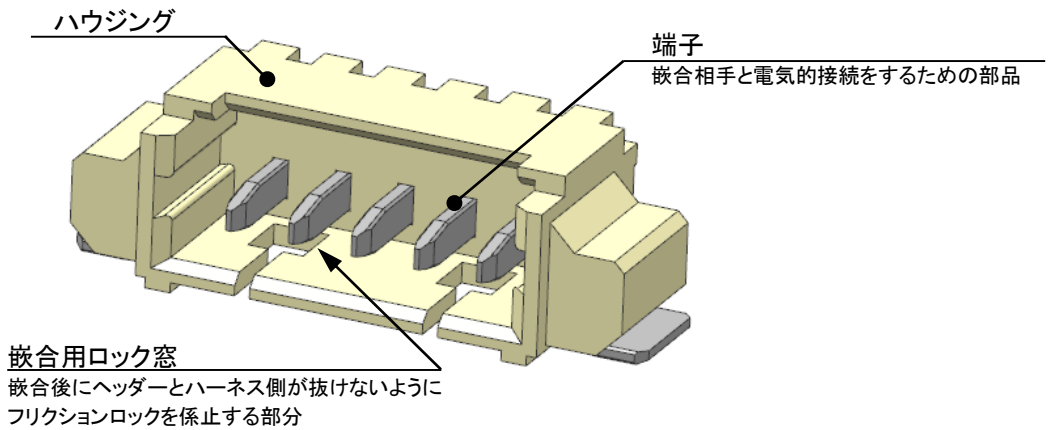

Fig. 3-6 SMT R/A type: 53261 series

REVISE ON PC ONLY		TITLE: PicoBlade 1.25 DIP TYPE & SMT TYPE APPLICATION SPECIFICATION			
A	SEE SHEET 1 OF 58				
REV.	DESCRIPTION	THIS DOCUMENT CONTAINS INFORMATION THAT IS PROPRIETARY TO MOLEX ELECTRONIC TECHNOLOGIES, LLC AND SHOULD NOT BE USED WITHOUT WRITTEN PERMISSION			
DOCUMENT NUMBER 510210000-AS		DOC. TYPE PS	DOC. PART 000	CUSTOMER GENERAL	SHEET 39 OF 58
EN-127(2015-12)					

【4. 端子圧着加工について】

4-1. 圧着前の外観確認項目

圧着前に、製品外観の変形、コンタクトボックスの潰れ等が無いことを確認してください。
また、端子同士が絡んでいる場合無理に引き剥がさないでください。変形等の原因となります。
尚、製品形状及び寸法については弊社製品図面を参照願います。

4-2. 圧着後の外観確認項目

圧着加工後の外観確認項目及び圧着不良について下記に示します。圧着時の参考としてください。
尚、圧着高さ、適用電線等の詳細は、弊社圧着仕様書を参照願います。

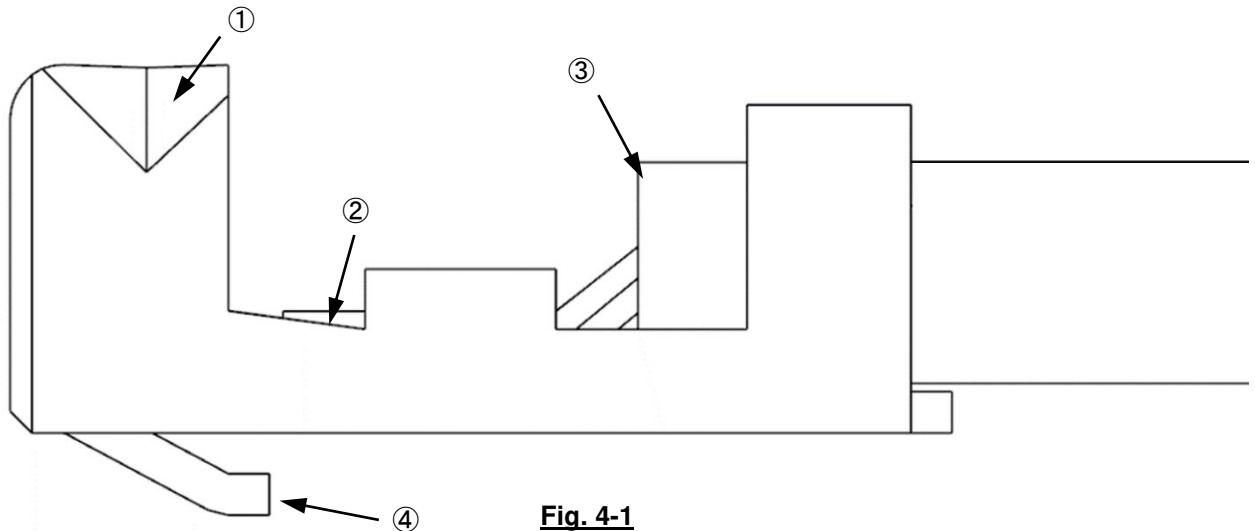

Fig. 4-1

- ① 接点部及びコンタクトボックスの潰れ、変形が無い。
- ② 芯線がワイヤーバレルより出ている、端子の外側に飛び出していない。
- ③ 電線の絶縁被覆ストリップ部分がワイヤーバレルとインシュレーションバレルのほぼ中間に位置している。
- ④ ランス部に変形が無い。
- ⑤ その他、外観に異常なきこと。（汚れ／異物付着など）

REVISE ON PC ONLY		TITLE: PicoBlade 1.25 DIP TYPE & SMT TYPE APPLICATION SPECIFICATION			
A	SEE SHEET 1 OF 58				
REV.	DESCRIPTION	THIS DOCUMENT CONTAINS INFORMATION THAT IS PROPRIETARY TO MOLEX ELECTRONIC TECHNOLOGIES, LLC AND SHOULD NOT BE USED WITHOUT WRITTEN PERMISSION			
DOCUMENT NUMBER 510210000-AS		DOC. TYPE PS	DOC. PART 000	CUSTOMER GENERAL	SHEET 40 OF 58

4-3. 圧着不良について

下記に示す圧着不良はハウジングへの挿入作業及び製品機能に影響を与えますので、特に御注意願います。

① ベンドアップ

ハウジングへの挿入性及び保持力の低下、また電氣的に接触しないなどの接触信頼性低下の原因となります。

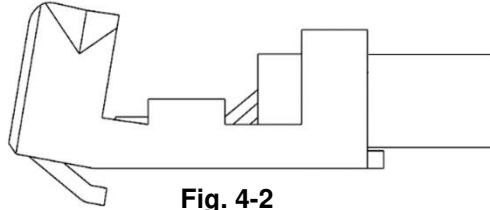

Fig. 4-2

② ベンドダウン

ハウジングへの挿入性及び保持力の低下、また電氣的に接触しないなどの接触信頼性低下の原因となります。

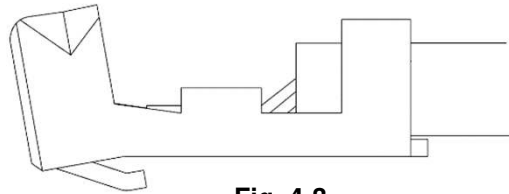
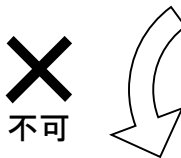

Fig. 4-3

③ ツイスト

ハウジングへの挿入性及び保持力の低下、また電氣的に接触しないなどの接触信頼性低下の原因となります。

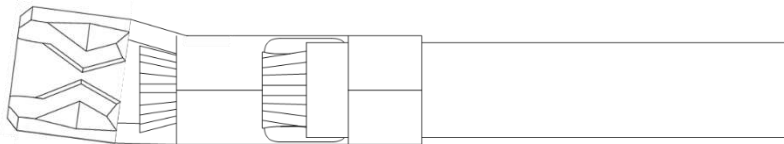
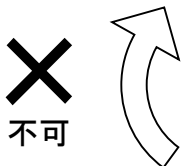
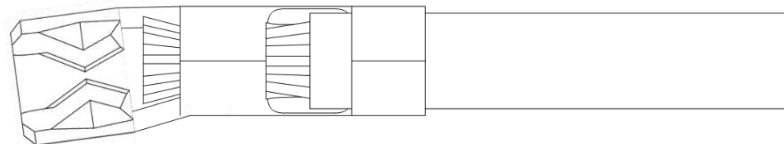
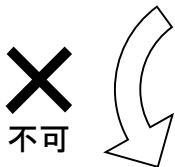
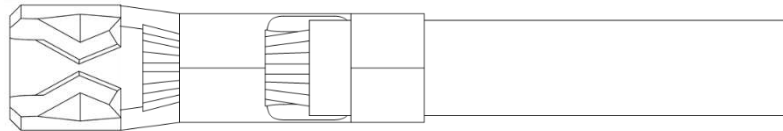

Fig. 4-4

REVISE ON PC ONLY		TITLE: PicoBlade 1.25 DIP TYPE & SMT TYPE APPLICATION SPECIFICATION			
A	SEE SHEET 1 OF 58				
REV.	DESCRIPTION	THIS DOCUMENT CONTAINS INFORMATION THAT IS PROPRIETARY TO MOLEX ELECTRONIC TECHNOLOGIES, LLC AND SHOULD NOT BE USED WITHOUT WRITTEN PERMISSION			
DOCUMENT NUMBER 510210000-AS		DOC. TYPE PS	DOC. PART 000	CUSTOMER GENERAL	SHEET 41 OF 58
EN-127(2015-12)					

④ ローリング

ハウジングへの挿入性及び保持力の低下、また電氣的に接触しないなどの接触信頼性低下の原因となります。

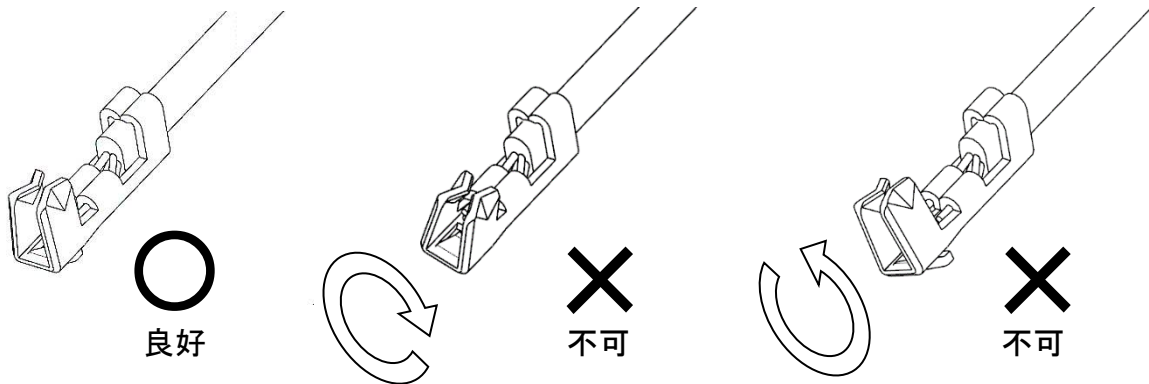

Fig. 4-5

⑤ 接点部及びコンタクトボックスの潰れ、変形

ハウジングへの挿入性及び保持力の低下、電氣的に接触しないなどの接触信頼性低下の原因となります。

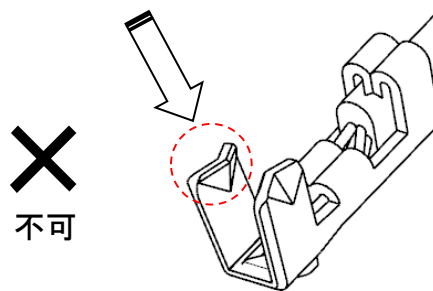

Fig. 4-6

⑥ 芯線はみだし

ハウジングへの挿入時に於ける作業性の低下、接触信頼性の低下の原因となります。

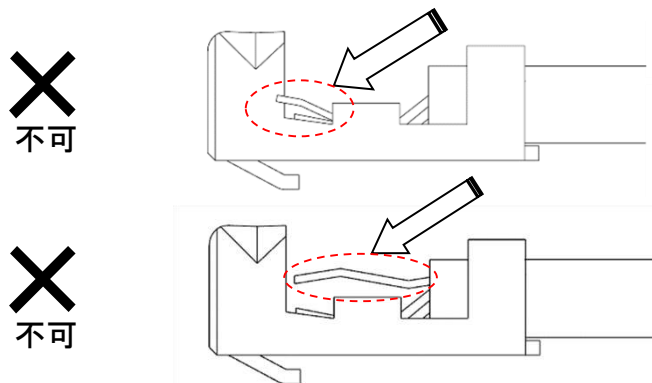

Fig. 4-7

REVISE ON PC ONLY		TITLE:		
A	SEE SHEET 1 OF 58	PicoBlade 1.25 DIP TYPE & SMT TYPE APPLICATION SPECIFICATION		
REV.	DESCRIPTION	THIS DOCUMENT CONTAINS INFORMATION THAT IS PROPRIETARY TO MOLEX ELECTRONIC TECHNOLOGIES, LLC AND SHOULD NOT BE USED WITHOUT WRITTEN PERMISSION		
DOCUMENT NUMBER 510210000-AS		DOC. TYPE PS	DOC. PART 000	CUSTOMER GENERAL
				SHEET 42 OF 58
EN-127(2015-12)				

⑦ 電線圧着位置—前過ぎ

断線、圧着部の引張り強度の低下や、ワイヤーバレルにて電線被覆を圧着した場合、電氣的に通電しないなど性能を満足出来なくなる原因となります。

×
不可

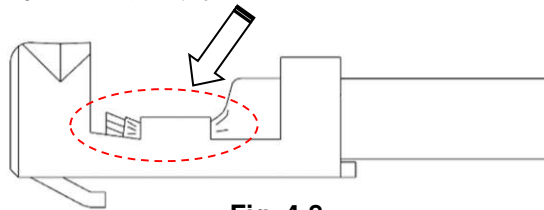
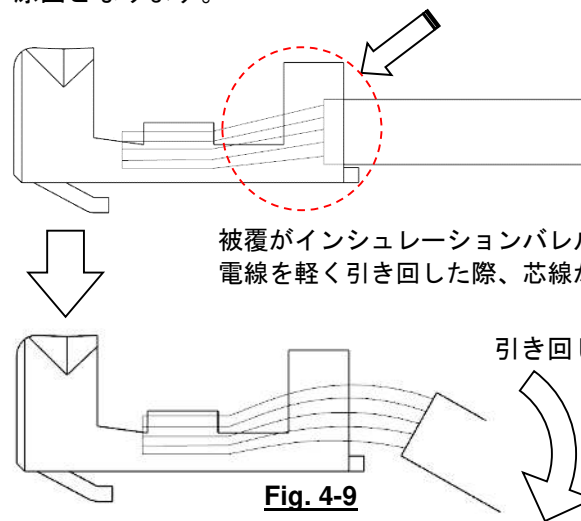

Fig. 4-8

⑧ 電線圧着位置—後ろ過ぎ

圧着がバレル内側で行われるため、圧着部の引張り強度が低下してしまう恐れや、また、電氣的に通電しないなど性能を満足できない原因となります。

×
不可



被覆がインシュレーションバレル全体で保持されていないため、電線を軽く引き回した際、芯線を容易に露出してしまう。

Fig. 4-9

⑨ ターミナルランスの変形（潰れなど）

ハウジングへの係止が不十分となり保持力の低下の原因となります。

×
不可

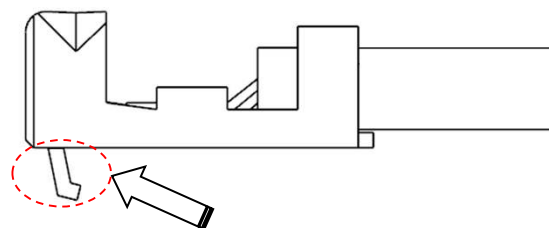

×
不可

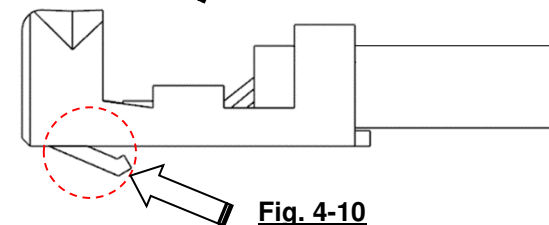

Fig. 4-10

REVISE ON PC ONLY

A

SEE SHEET 1 OF 58

TITLE:

**PicoBlade 1.25 DIP TYPE & SMT TYPE
APPLICATION SPECIFICATION**

THIS DOCUMENT CONTAINS INFORMATION THAT IS PROPRIETARY TO MOLEX ELECTRONIC TECHNOLOGIES, LLC AND SHOULD NOT BE USED WITHOUT WRITTEN PERMISSION

REV.

DESCRIPTION

DOCUMENT NUMBER
510210000-AS

DOC. TYPE
PS

DOC. PART
000

CUSTOMER
GENERAL

SHEET
43 OF 58

【5. 圧着後の電線結束および梱包について】

圧着後の電線加工品を束ねる際には絡みによる端子の変形・傷・電線の被覆破れ等が発生しないよう御配慮をお願いします。

(輪ゴム等で結束する際には端子圧着部から30mm程度の位置にての結束を推奨いたします。**Fig.5-1**)
又、加工後梱包箱への詰込みを行う際には詰込み過多による製品変形等も考えられますので1箱あたりの梱包重量についても御配慮願います。

注意事項

※加工品の束を梱包箱に入れる際、積み重ねによる荷重等の負荷が端子へ直接長時間加わらない様、交互に重ねるなどしてください。(Fig.5-2)

※梱包箱底面および上面には、緩衝材等を敷いてください。また、段積みによる荷重等の負荷が端子へ直接長時間加わらない様に、緩衝材を敷く等の御配慮をお願い致します。(Fig.5-2)

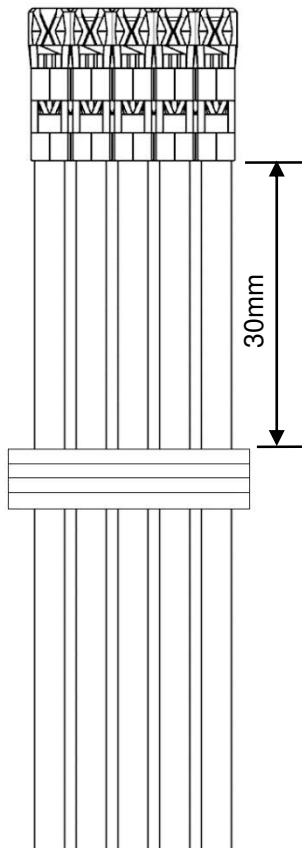

Fig. 5-1

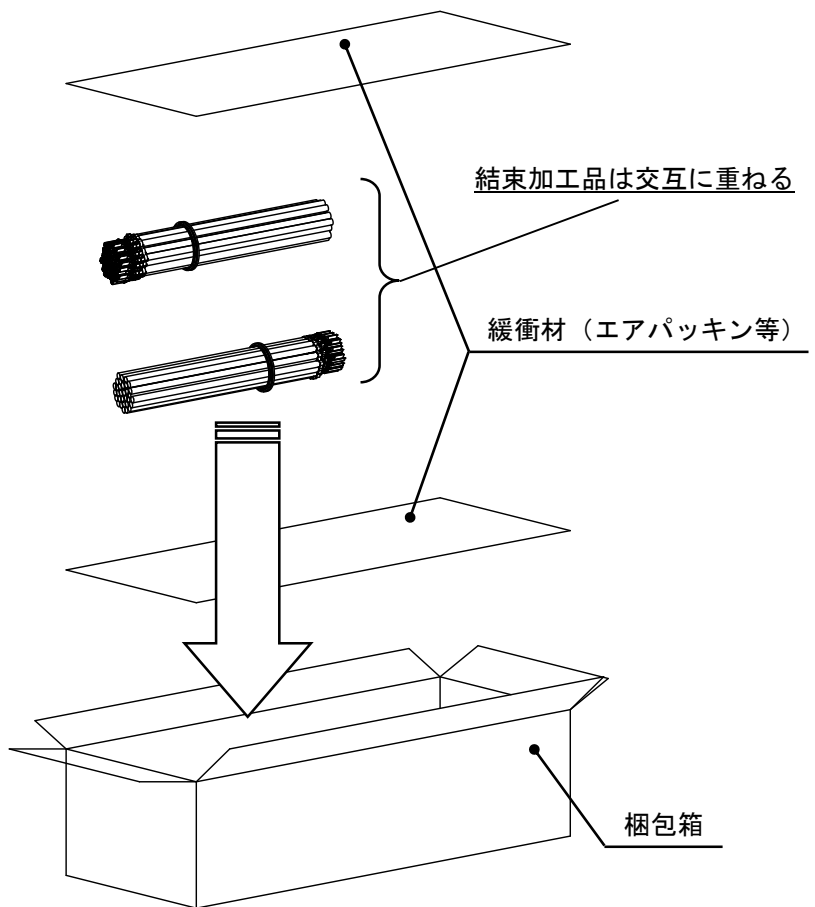

Fig. 5-2

REVISE ON PC ONLY		TITLE: PicoBlade 1.25 DIP TYPE & SMT TYPE APPLICATION SPECIFICATION		
A	SEE SHEET 1 OF 58			
REV.	DESCRIPTION	THIS DOCUMENT CONTAINS INFORMATION THAT IS PROPRIETARY TO MOLEX ELECTRONIC TECHNOLOGIES, LLC AND SHOULD NOT BE USED WITHOUT WRITTEN PERMISSION		
DOCUMENT NUMBER 510210000-AS	DOC. TYPE PS	DOC. PART 000	CUSTOMER GENERAL	SHEET 44 OF 58
EN-127(2015-12)				

【6.リセプタクルハウジングへの圧着端子装着（ハーネス作業）方法】

圧着端子の装着およびリペアの手順と注意事項（※）を下記に示します。

6-1. 圧着端子の装着について

- ① リセプタクルハウジングの左右を挟むように、軽く持ってください。
※モールドランス部を持って圧着端子を挿入しようとするとモールドランスが可動しにくくなり、圧着端子が挿入しにくくなったりコネクタが破損、変形したりする可能性があります。（Fig.6-1）

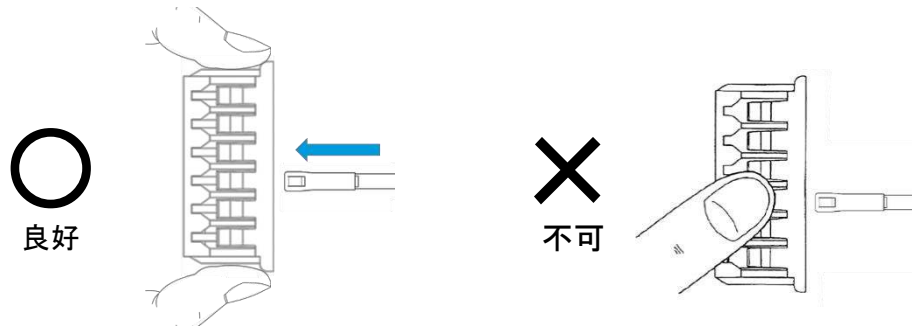

Fig. 6-1

- ② ケーブルは、端子圧着部から約 10mm の位置を指で軽く摘んで持ってください。
※端子から離れた位置で持ち過ぎますと、電線が曲がり易くなり、挿入しづらくなる場合が御座います。
※数値は目安です。使用する電線の種類、材質により数値は異なりますので、使用前に御確認ください。

- ③ ターミナルランス部が、モールドランス部に向かうように持ち、端子が突き当たる位置まで（2~4N 程度の力で）ゆっくりと真っ直ぐ装着してください。（Fig.6-2）

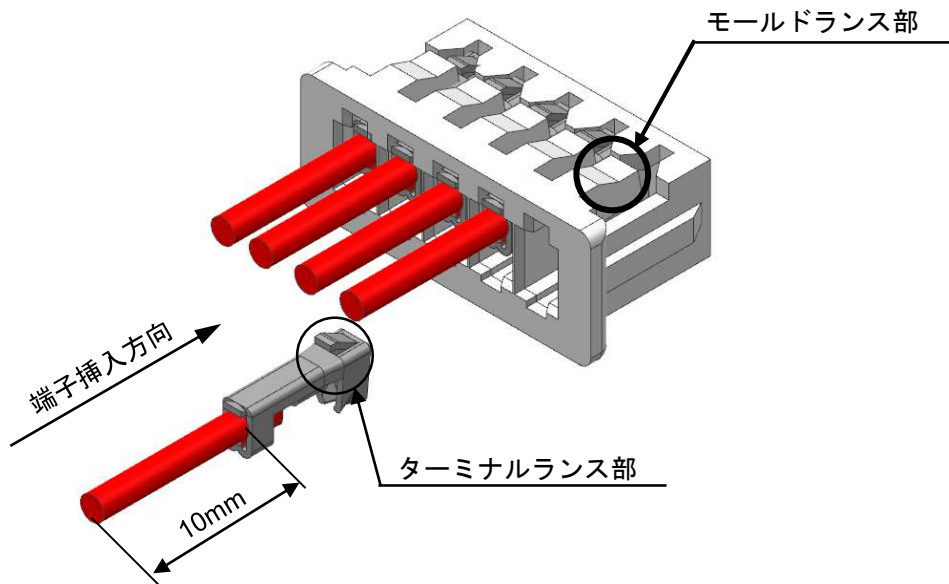

Fig. 6-2

REVISE ON PC ONLY		TITLE: PicoBlade 1.25 DIP TYPE & SMT TYPE APPLICATION SPECIFICATION			
A	SEE SHEET 1 OF 58				
REV.	DESCRIPTION	THIS DOCUMENT CONTAINS INFORMATION THAT IS PROPRIETARY TO MOLEX ELECTRONIC TECHNOLOGIES, LLC AND SHOULD NOT BE USED WITHOUT WRITTEN PERMISSION			
DOCUMENT NUMBER 510210000-AS		DOC. TYPE PS	DOC. PART 000	CUSTOMER GENERAL	SHEET 45 OF 58
EN-127(2015-12)					

注意事項

※圧着高さ及び幅が大きいと端子挿入に問題がある場合があるため、規定の圧着高さにて作業を行ってください。（弊社圧着仕様書をご参照願います。）

※リセプタクルハウジングに対して圧着端子を装着する向きにご注意ください。

装着時、端子がハウジングに対して上下逆、斜め、5度以上回転した状態にならないように御注意ください。端子変形、ハウジング破損の原因となります。（Fig.6-3, 6-4）

※装着途中で引っ掛かり等の異常を感じた際には無理に装着せず、端子やハウジングの変形などが無いことを確認し、再度装着し直してください。変形などが確認された場合、その端子やハウジングは、再使用しないでください。

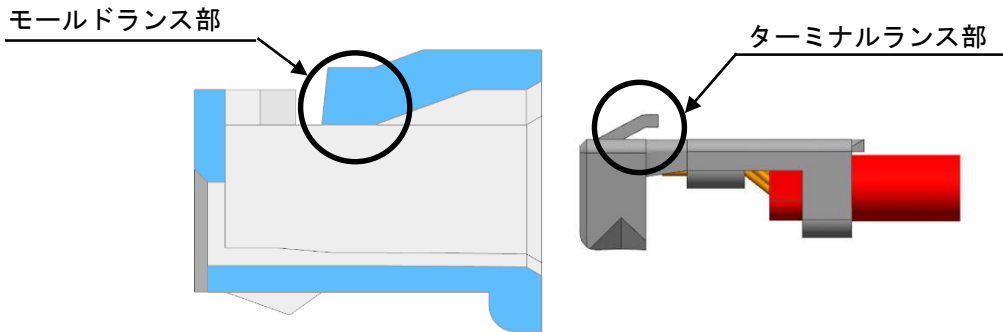

○ Fig.6-3 正しい端子挿入

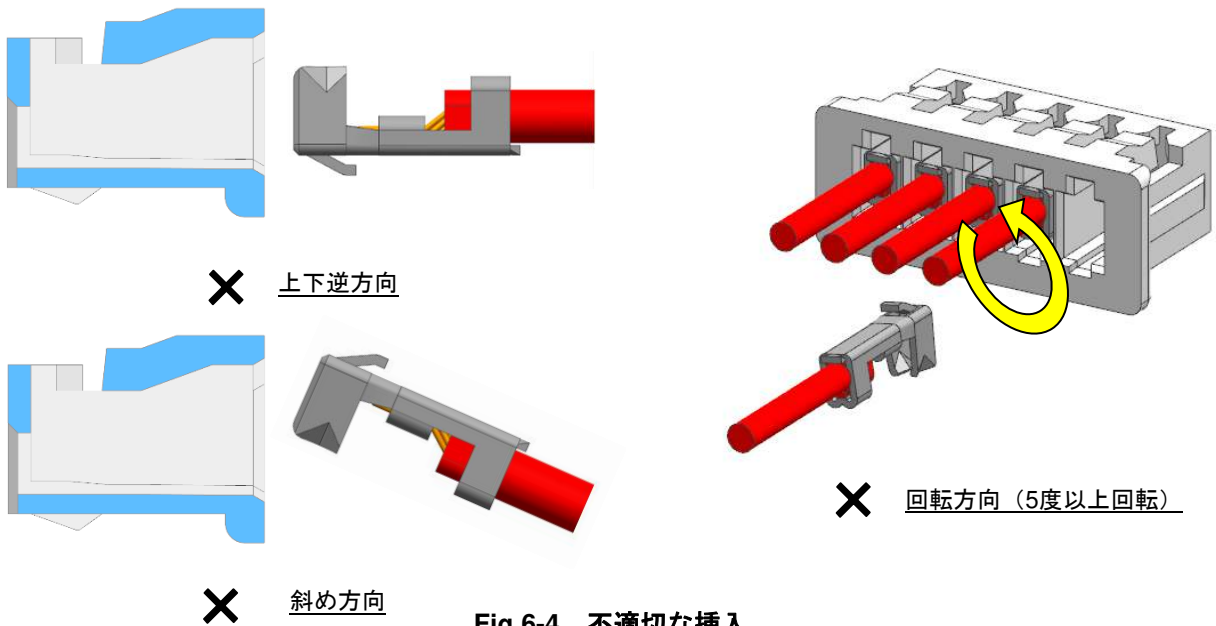
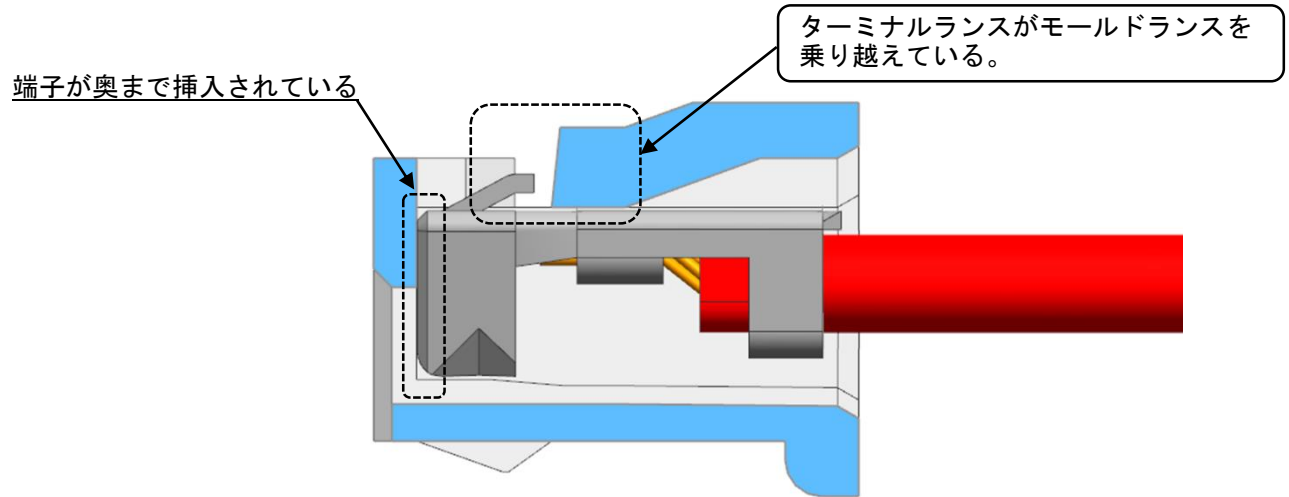

Fig.6-4 不適切な挿入

REVISE ON PC ONLY		TITLE: PicoBlade 1.25 DIP TYPE & SMT TYPE APPLICATION SPECIFICATION			
A	SEE SHEET 1 OF 58				
REV.	DESCRIPTION	THIS DOCUMENT CONTAINS INFORMATION THAT IS PROPRIETARY TO MOLEX ELECTRONIC TECHNOLOGIES, LLC AND SHOULD NOT BE USED WITHOUT WRITTEN PERMISSION			
DOCUMENT NUMBER 510210000-AS		DOC. TYPE PS	DOC. PART 000	CUSTOMER GENERAL	SHEET 46 OF 58

- ④ 端子装着後、軽く（100g 程度の力で）電線を引張り、端子が抜け出さないか確認を行ってください。（過度の引張りでの確認はコネクタを破損させる場合が御座います。）
- ⑤ すべての端子の装着後、モールドランス部およびターミナルランス部の位置を確認してください。正しく装着されている場合は、ターミナルランス部がきちんとモールドランスを乗り越えた位置にあります。（Fig.6-5, 6-6）



○ Fig.6-5 正しく装着されている状態

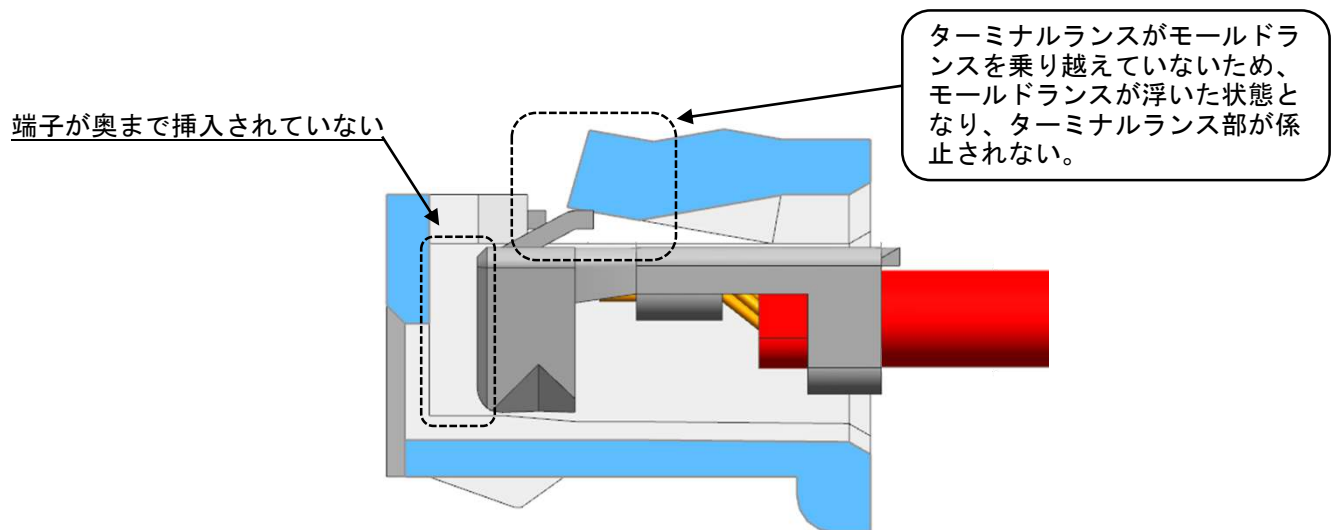

✕ Fig.6-6 不完全装着の状態

REVISE ON PC ONLY		TITLE: PicoBlade 1.25 DIP TYPE & SMT TYPE APPLICATION SPECIFICATION			
A	SEE SHEET 1 OF 58				
REV.	DESCRIPTION	THIS DOCUMENT CONTAINS INFORMATION THAT IS PROPRIETARY TO MOLEX ELECTRONIC TECHNOLOGIES, LLC AND SHOULD NOT BE USED WITHOUT WRITTEN PERMISSION			
DOCUMENT NUMBER 510210000-AS		DOC. TYPE PS	DOC. PART 000	CUSTOMER GENERAL	SHEET 47 OF 58

注意事項

※端子が不完全装着の場合、端子のランス部にモールドランスが引っ掛からない状態になり、端子が保持出来なくなります。

※モールドランスが正規の位置に戻っていない箇所（不完全装着状態：Fig.6-6参照）では、モールドランスが最も変形している状態です。そのため、この状態で保持されたハーネス品は、モールドランスが正規の位置に戻らず、端子を再挿入したとしても保持力が低下する場合がございます。このような場合は、必ずハウジングを取り替えて頂くよう、お願い致します。

- ⑥ ハーネス加工後のチェック時には、電線を極端に曲げる、または突っ張る状態での使用は避けてください。電線の張力により端子圧着部やリセプタクルハウジングの端子装着部に力が加わり、接点不良の原因となります。
- ⑦ ハーネス加工後における導通チェックの際には適合する嵌合相手以外のものに挿入しないでください。端子の変形等による接触不良の原因となります。

REVISE ON PC ONLY		TITLE: PicoBlade 1.25 DIP TYPE & SMT TYPE APPLICATION SPECIFICATION			
A	SEE SHEET 1 OF 58				
REV.	DESCRIPTION	THIS DOCUMENT CONTAINS INFORMATION THAT IS PROPRIETARY TO MOLEX ELECTRONIC TECHNOLOGIES, LLC AND SHOULD NOT BE USED WITHOUT WRITTEN PERMISSION			
DOCUMENT NUMBER 510210000-AS		DOC. TYPE PS	DOC. PART 000	CUSTOMER GENERAL	SHEET 48 OF 58
EN-127(2015-12)					

6-2. 圧着端子のリペアについて

一度リセプタクルハウジングに挿入した圧着端子を抜く時は、圧着端子引抜工具57072-6000を使いモールドランスを持ち上げながら、電線と冶具をまとめてつかんで引き抜いて下さい。但し、モールドランスを無理に持ち上げると変形してしまいます。変形した箇所のランス強度は極端に低下するため、端子を再装着したとしても直ぐに抜けてくる可能性が御座います。そのため、**圧着端子のリペアの際には新しいリセプタクルハウジングを必ず使用して下さい。**また、拡大鏡等を使うなどして、十分御注意の上、作業を行って下さい。

注意事項

- ※端子を無理に引き抜くことは、必ず避けてください。
- ※リペアの際、端子のランス部の変形や傷を付けないように御注意ください。
- ※引抜工具57072-6000をご使用頂く際は、引抜工具の取扱説明書も合わせてご確認ください。

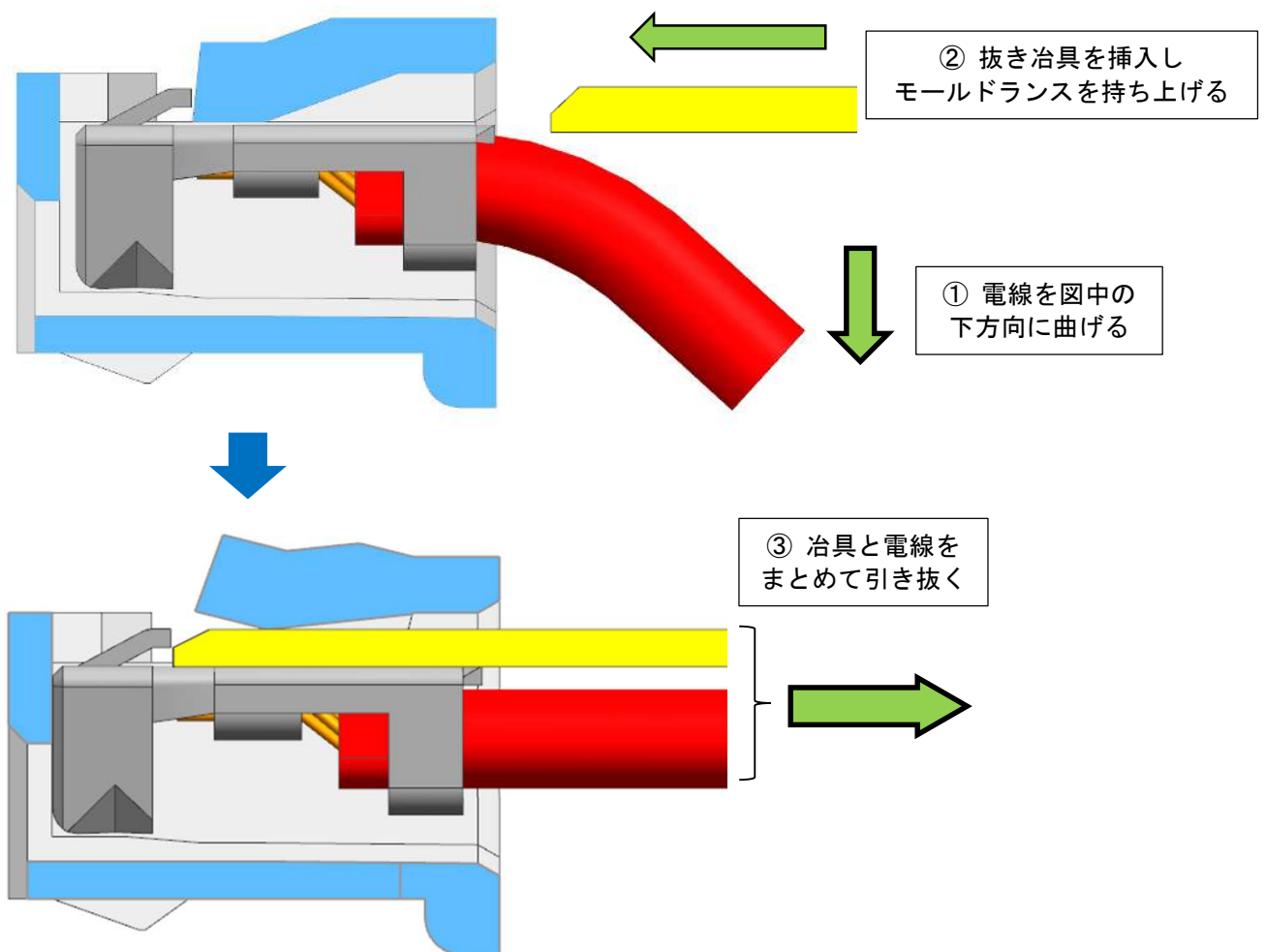

Fig.6-7

REVISE ON PC ONLY		TITLE: PicoBlade 1.25 DIP TYPE & SMT TYPE APPLICATION SPECIFICATION			
A	SEE SHEET 1 OF 58				
REV.	DESCRIPTION	THIS DOCUMENT CONTAINS INFORMATION THAT IS PROPRIETARY TO MOLEX ELECTRONIC TECHNOLOGIES, LLC AND SHOULD NOT BE USED WITHOUT WRITTEN PERMISSION			
DOCUMENT NUMBER 510210000-AS		DOC. TYPE PS	DOC. PART 000	CUSTOMER GENERAL	SHEET 49 OF 58
EN-127(2015-12)					

【7. ハーネス結束について】

ハーネス後の結束の際、下記の点に御配慮願います。

- ① 電線の結束は、コネクタから 50mm 以上のところで、電線に加わる力が均一になるようにしてください。**(Fig.7-1)**
- ② ハーネス品で、電線一本（又は特定の数本）に力が加わらない様にしてください。**(Fig.7-2)**

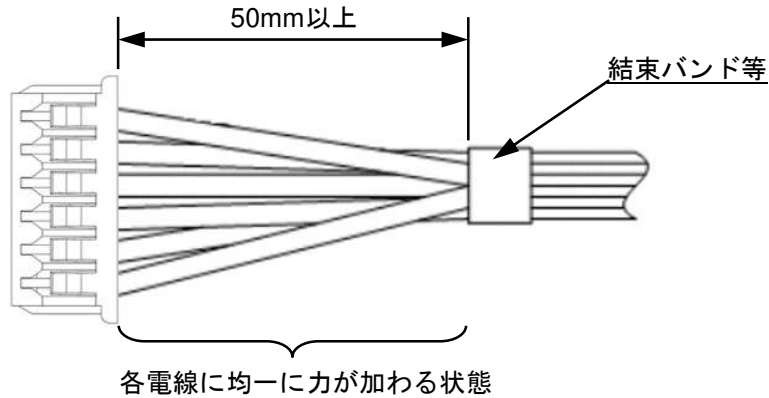

Fig.7-1 適切なハーネス結束状態

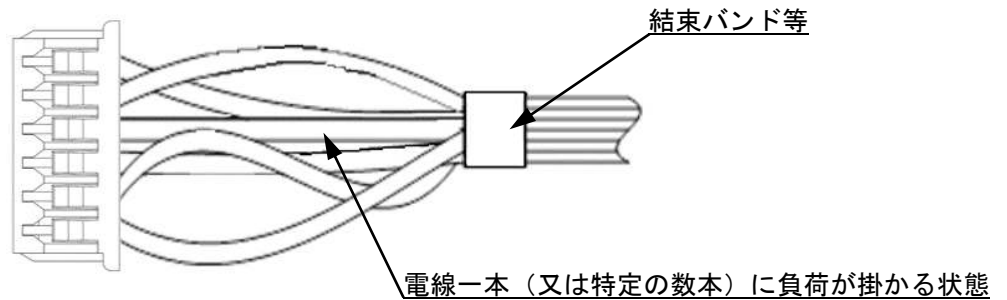

Fig.7-2 不適切なハーネス結束状態

注意事項

- ※ハーネス品同士が絡まっている場合、無理に引っ張らないでください。過度な力が加わり端子が抜ける等の不具合が生じ、コネクタが破損する場合があります。
- ※製品を落としたり、他のものにぶついたりしないでください。

REVISE ON PC ONLY		TITLE: PicoBlade 1.25 DIP TYPE & SMT TYPE APPLICATION SPECIFICATION			
A	SEE SHEET 1 OF 58				
REV.	DESCRIPTION	THIS DOCUMENT CONTAINS INFORMATION THAT IS PROPRIETARY TO MOLEX ELECTRONIC TECHNOLOGIES, LLC AND SHOULD NOT BE USED WITHOUT WRITTEN PERMISSION			
DOCUMENT NUMBER 510210000-AS		DOC. TYPE PS	DOC. PART 000	CUSTOMER GENERAL	SHEET 50 OF 58
EN-127(2015-12)					

③ ハーネス後に電線を曲げる必要がある場合は、コネクタに直接負荷がかからないように電線にたわみを持たせてください。御参考までに推奨および非推奨のハーネス曲げ方法をそれぞれ例示いたします。(Fig. 7-3, 7-4)

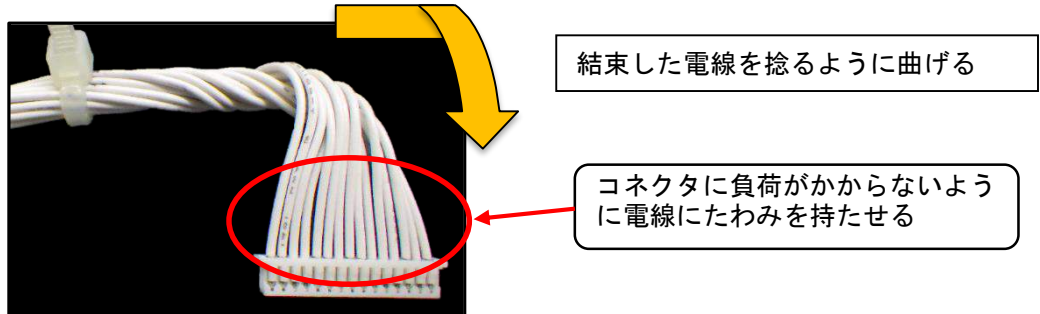
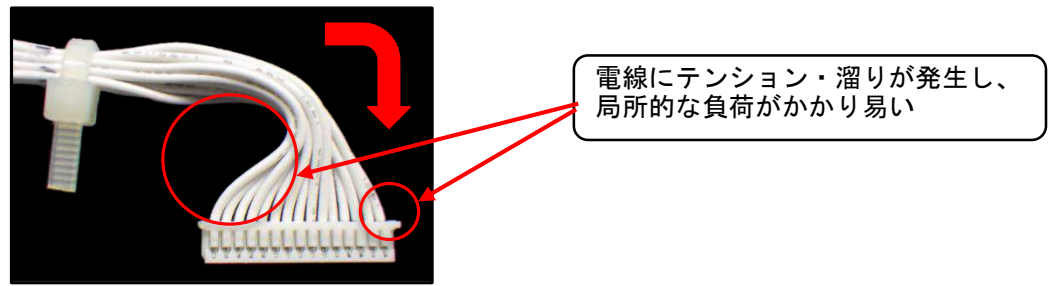
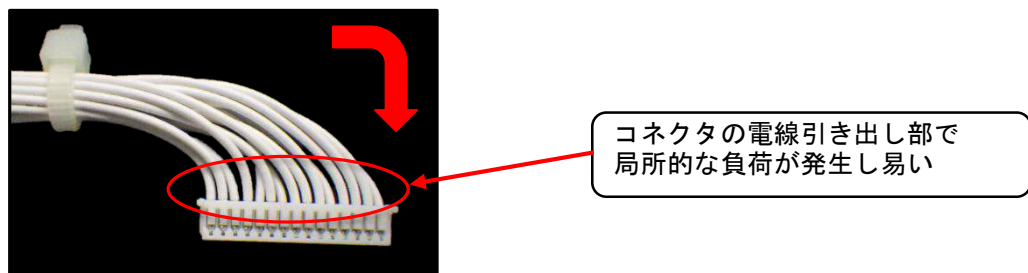

Fig. 7-3 推奨するハーネス曲げ方法 (参考)



結束したハーネスを単純に曲げた場合



電線を曲げた後に結束した場合

Fig. 7-4 非推奨のハーネス曲げ方法

REVISE ON PC ONLY		TITLE: PicoBlade 1.25 DIP TYPE & SMT TYPE APPLICATION SPECIFICATION			
A	SEE SHEET 1 OF 58				
REV.	DESCRIPTION	THIS DOCUMENT CONTAINS INFORMATION THAT IS PROPRIETARY TO MOLEX ELECTRONIC TECHNOLOGIES, LLC AND SHOULD NOT BE USED WITHOUT WRITTEN PERMISSION			
DOCUMENT NUMBER 510210000-AS		DOC. TYPE PS	DOC. PART 000	CUSTOMER GENERAL	SHEET 51 OF 58

【8. ハーネス梱包について】

ハーネス加工品を梱包する際の手順と注意事項（※）を下記に示します。

- ① ハーネス加工品を束ねる。一束でハーネス最大20本を目安として束ねるようにしてください。

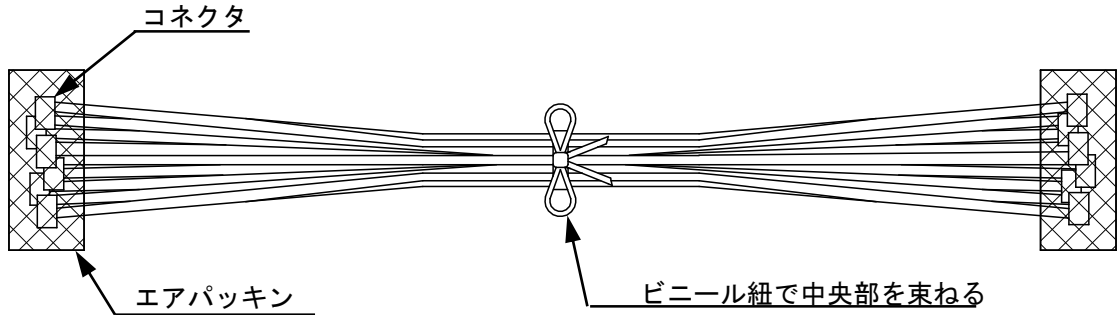

Fig.8-1 ハーネス加工品一束の状態図

注意事項

※束ねる際に、常時無理な力が電線に加わらない様に、輪ゴムのような締め付けの強いものは使用せず、ビニール紐で中央部（一箇所）を束ねてください。また、各束のコネクタにエアパッキンを巻き、衝撃や荷重からコネクタを保護する処置をお願い致します。（Fig.8-1）

REVISE ON PC ONLY		TITLE: PicoBlade 1.25 DIP TYPE & SMT TYPE APPLICATION SPECIFICATION			
A	SEE SHEET 1 OF 58				
REV.	DESCRIPTION	THIS DOCUMENT CONTAINS INFORMATION THAT IS PROPRIETARY TO MOLEX ELECTRONIC TECHNOLOGIES, LLC AND SHOULD NOT BE USED WITHOUT WRITTEN PERMISSION			
DOCUMENT NUMBER 510210000-AS		DOC. TYPE PS	DOC. PART 000	CUSTOMER GENERAL	SHEET 52 OF 58
EN-127(2015-12)					

- ② 梱包箱に束ねたハーネス加工品を入れる。尚、下図 (Fig. 8-2) は推奨参考例ですが、ハーネス長が長いなどの理由で他の梱包方式で御使用される場合にも段積みによる荷重等の負荷がコネクタに長時間加わらない様御配慮をお願い致します。

注意事項

※ハーネス加工品の束を梱包箱に入れる際、積み重ねによる荷重等の負荷がコネクタに長時間加わらない様に、箱に合わせた形で製品を交互（十字型）に重ね合わせてください。(Fig.8-2 ①)

※梱包箱底面には、緩衝材等を敷いてください。また、段積みによる荷重等の負荷がコネクタに長時間加わらない様に、緩衝材を敷く等の御配慮をお願い致します。(Fig.8-2 ②)

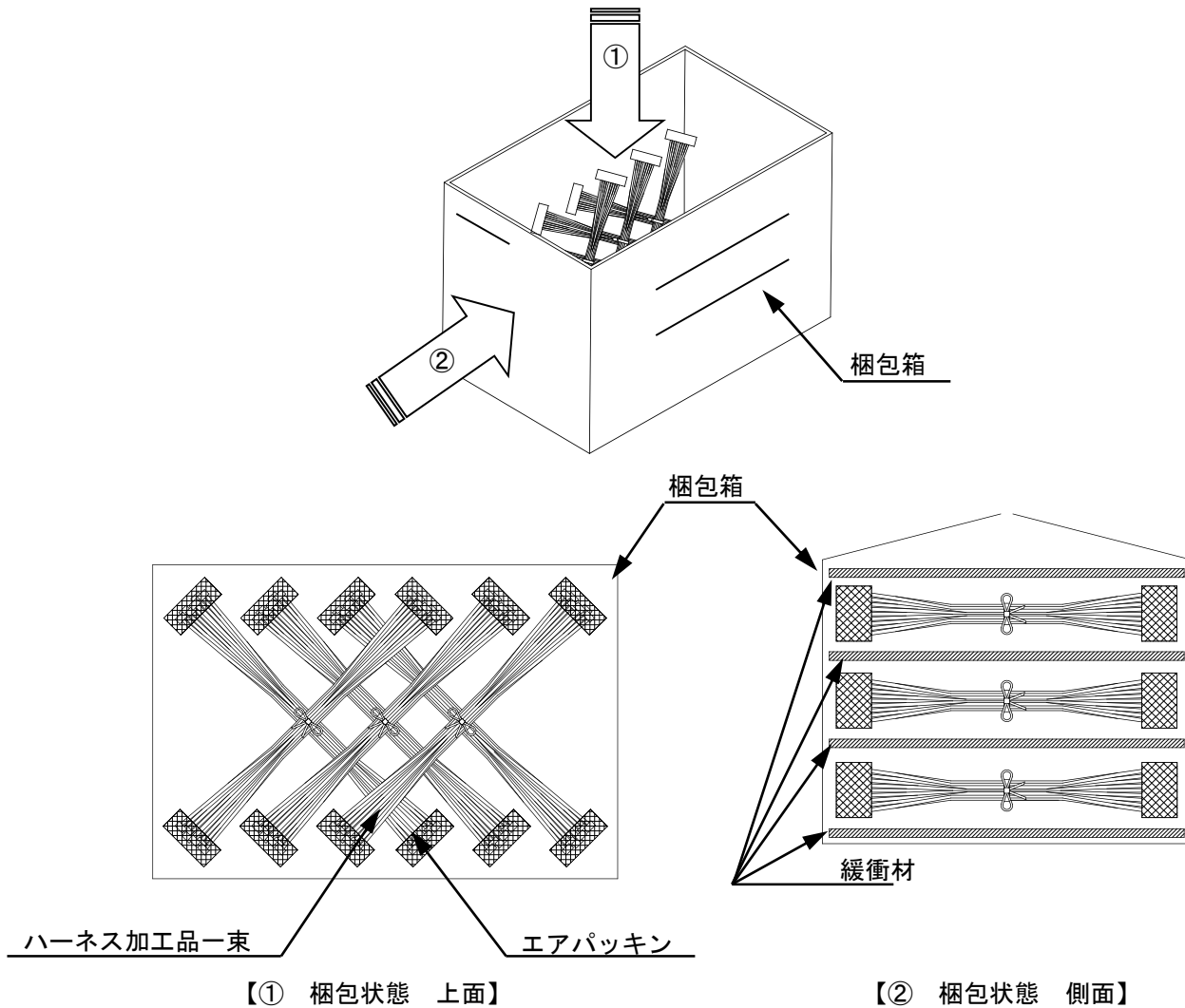

Fig.8-2 梱包状態図

REVISE ON PC ONLY		TITLE: PicoBlade 1.25 DIP TYPE & SMT TYPE APPLICATION SPECIFICATION		
A	SEE SHEET 1 OF 58			
REV.	DESCRIPTION	THIS DOCUMENT CONTAINS INFORMATION THAT IS PROPRIETARY TO MOLEX ELECTRONIC TECHNOLOGIES, LLC AND SHOULD NOT BE USED WITHOUT WRITTEN PERMISSION		
DOCUMENT NUMBER 510210000-AS	DOC. TYPE PS	DOC. PART 000	CUSTOMER GENERAL	SHEET 53 OF 58

【9.基板側コネクタの実装について】

- ① コネクタ及び基板、メタルマスク（SMTタイプ）の寸法が弊社製品図面に合致しているかどうか確認して下さい。
- ② DIPタイプコネクタを実装する際は、コネクタを基板に対して水平に真っ直ぐ挿入して下さい。斜めにしたりコジリを加えないで下さい。また、下記の注意事項もご参照ください。

注意事項

- ※コネクタを保持する際にはコンタクトに触れることの無い様に御注意下さい。
- ※コネクタを基板に対して水平に保持した状態で真っ直ぐにソルダーテールを基板穴へ挿入して下さい。
- ※基板穴とソルダーテールがずれる方向や斜めに傾く様な力を加えないで下さい。
- ※無理に斜め挿入を行った場合、ピンの変形、抜けが生じ、コネクタが破損します。
- ※スムーズに挿入出来ない場合は無理に挿入せず製品や基板の変形、基板寸法等の確認を御願い致します。挿入異常が生じた状態で無理に挿入を行った場合にはピンや基板に損傷を与える恐れが御座います。

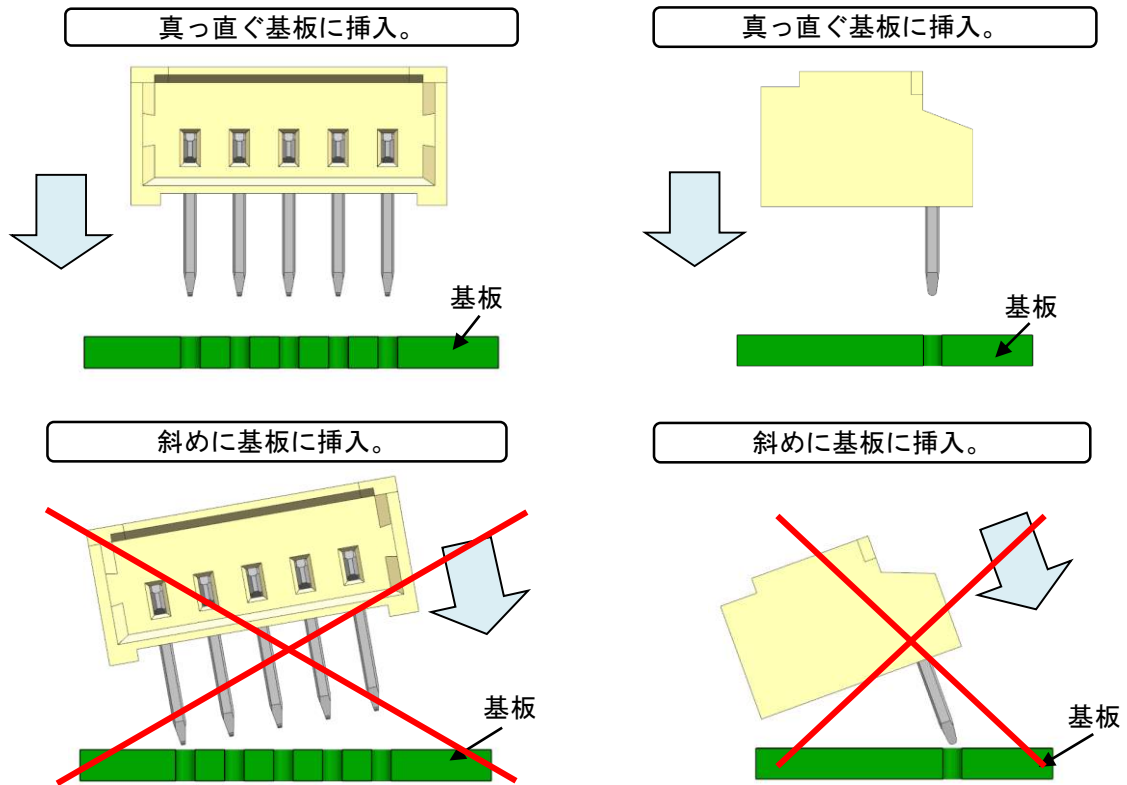

REVISE ON PC ONLY		TITLE: PicoBlade 1.25 DIP TYPE & SMT TYPE APPLICATION SPECIFICATION			
A	SEE SHEET 1 OF 58				
REV.	DESCRIPTION	THIS DOCUMENT CONTAINS INFORMATION THAT IS PROPRIETARY TO MOLEX ELECTRONIC TECHNOLOGIES, LLC AND SHOULD NOT BE USED WITHOUT WRITTEN PERMISSION			
DOCUMENT NUMBER 510210000-AS		DOC. TYPE PS	DOC. PART 000	CUSTOMER GENERAL	SHEET 54 OF 58
EN-127(2015-12)					

【10. 嵌合時に於ける注意事項】

10-1. 推奨挿入方法

プラグハウジング（基板側）とリセプタクルハウジング（ハーネス側）の嵌合方向を合わせ、嵌合時にリセプタクルハウジングのピッチ方向の両端（矢印で示す部位）を押し、**コネクタ同士が突き当たる（完全嵌合位置）まで、真っ直ぐ押し込んでください。**

リセプタクルハウジングの両端を
押して挿入して下さい

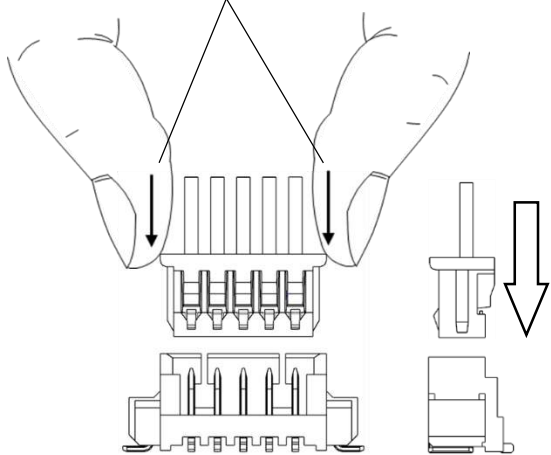

○ まっすぐ挿入
(ST,RA 共通)

Fig. 10-1

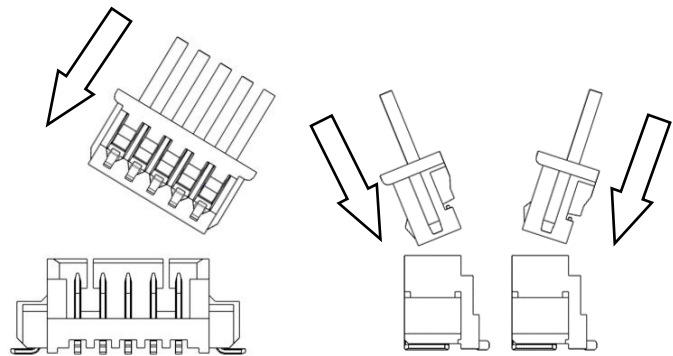

✕ 斜めに挿入
(ST,RA 共通)

Fig. 10-2

注意事項

※スムーズに挿入できない場合は、端子やハウジングの変形、嵌合方向を確認した上で
もう一度挿入してください。

REVISE ON PC ONLY

A

SEE SHEET 1 OF 58

TITLE:

**PicoBlade 1.25 DIP TYPE & SMT TYPE
APPLICATION SPECIFICATION**

THIS DOCUMENT CONTAINS INFORMATION THAT IS PROPRIETARY TO MOLEX ELECTRONIC
TECHNOLOGIES, LLC AND SHOULD NOT BE USED WITHOUT WRITTEN PERMISSION

REV.

DESCRIPTION

DOCUMENT NUMBER

510210000-AS

DOC. TYPE

PS

DOC. PART

000

CUSTOMER

GENERAL

SHEET

55 OF 58

10-2. 推奨抜去方法

電線はまとめて軽くつかみ、リセプタクルハウジングの淵に指を添え、軸方向にまっすぐにゆっくりと引き抜いてください。また、斜めにこじりながら抜くことは避けてください。コネクタを破損させる恐れが御座います。

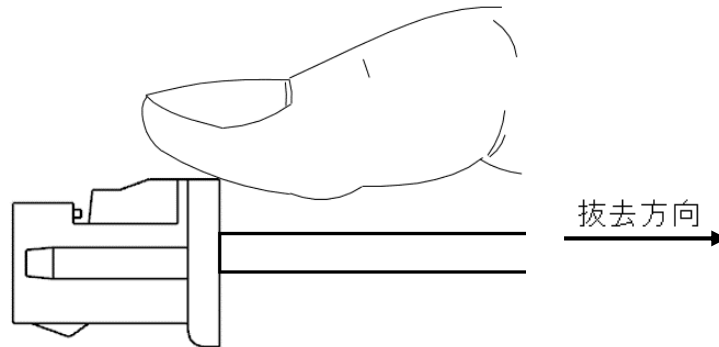

Fig.10-3

注意事項

※特定の数本のみ電線を摘んで抜去しないでください。限定された端子に過度な負荷が集中し、コネクタの破損及び端子が抜ける可能性が御座います。

10-3. 嵌合後の電線の引き回しについて

注意事項

- ※機器内の引き回しを検討される際には、電線に十分なたわみを持たせる等の処置を検討頂き、直接コネクタに力が加わらないようにしてください。(Fig.10-4)
- ※嵌合後、機器内での電線の引き回しの際には、電線を極端に曲げる、または突っ張る状態で使用しないでください。(Fig.10-5) 電線の引っ張り力、突っ張り力により端子圧着部やハウジングの端子装着部及び基板側のコネクタに力が加わり接点不良の原因となります。特に、特定の電線のみにも負荷が加わることは避けてください。負荷が加わると電線(圧着端子)が抜ける可能性が御座います。
- ※特定の電線一本に負荷が加わると、電線(圧着端子)が抜ける可能性がございます。
- ※嵌合後、機器内での電線の引き回しの際、2方向以上での引き回しは避けてください。(Fig. 10-6)
- ※特殊な電線の引き回し(Fig. 10-5, 10-6等)を行う際には、事前に弊社へ確認の上ご使用ください。

REVISE ON PC ONLY		TITLE: PicoBlade 1.25 DIP TYPE & SMT TYPE APPLICATION SPECIFICATION			
A	SEE SHEET 1 OF 58				
REV.	DESCRIPTION	THIS DOCUMENT CONTAINS INFORMATION THAT IS PROPRIETARY TO MOLEX ELECTRONIC TECHNOLOGIES, LLC AND SHOULD NOT BE USED WITHOUT WRITTEN PERMISSION			
DOCUMENT NUMBER 510210000-AS		DOC. TYPE PS	DOC. PART 000	CUSTOMER GENERAL	SHEET 56 OF 58
EN-127(2015-12)					

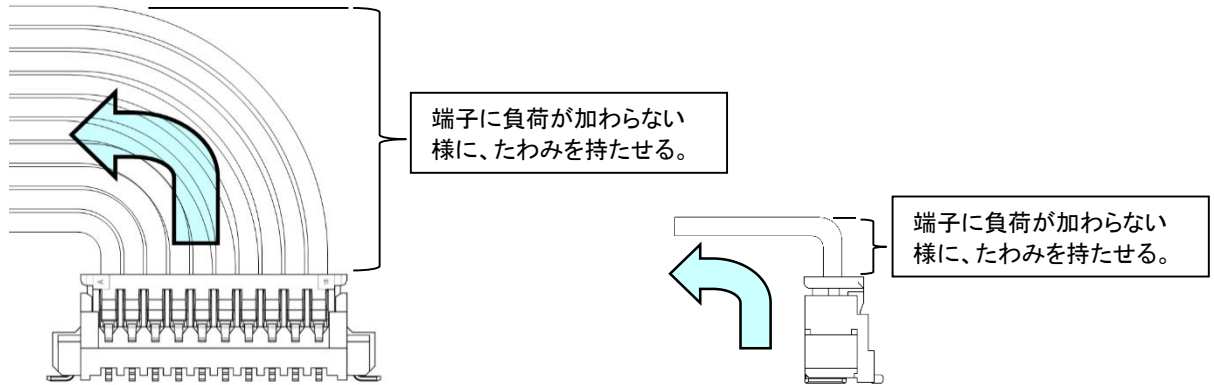

Fig. 10-4 電線にたわみを持たせた状態

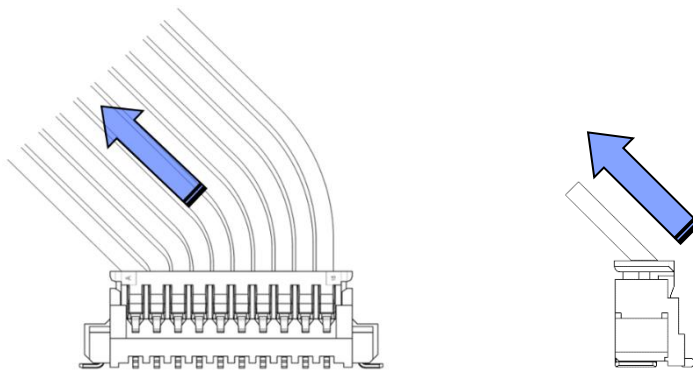

Fig. 10-5 電線を極端に曲げる又は、突っ張った状態

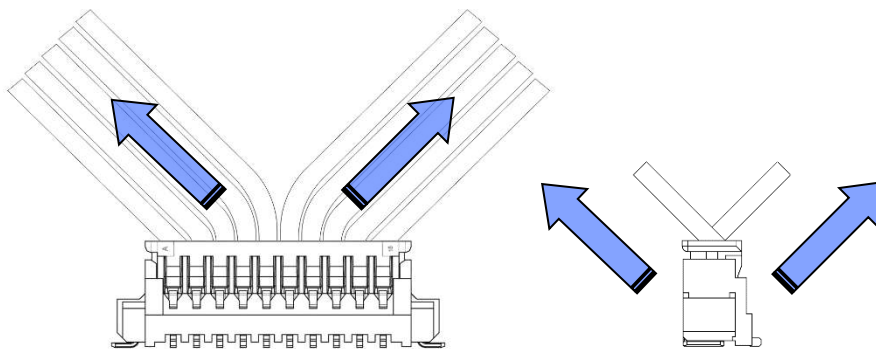

Fig. 10-6 2方向以上での電線引き回し状態

REVISE ON PC ONLY		TITLE: PicoBlade 1.25 DIP TYPE & SMT TYPE APPLICATION SPECIFICATION			
A	SEE SHEET 1 OF 58				
REV.	DESCRIPTION	THIS DOCUMENT CONTAINS INFORMATION THAT IS PROPRIETARY TO MOLEX ELECTRONIC TECHNOLOGIES, LLC AND SHOULD NOT BE USED WITHOUT WRITTEN PERMISSION			
DOCUMENT NUMBER 510210000-AS		DOC. TYPE PS	DOC. PART 000	CUSTOMER GENERAL	SHEET 57 OF 58
EN-127(2015-12)					

