

MITSUBISHI IGBT MODULES

CM400HX-24A

HIGH POWER SWITCHING USE

CM400HX-24A



- IC 400A
- VCES 1200V
- Single
- Flatbase Type / Insulated Package / Copper (non-plating) base plate
- RoHS Directive compliant

APPLICATION

General purpose Inverters, Servo Amplifiers, Power supply, etc.

OUTLINE DRAWING & CIRCUIT DIAGRAM

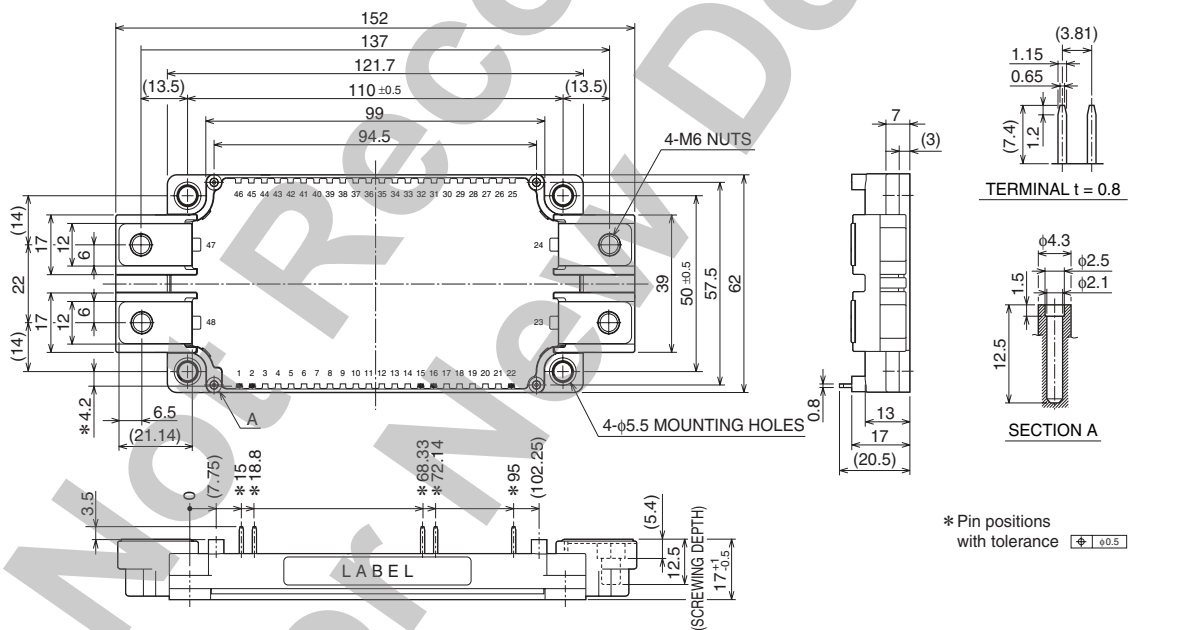

* Pin positions with tolerance ± 0.5

Tolerance otherwise specified

Division of Dimension	Tolerance
0.5 to 3	± 0.2
over 3 to 6	± 0.3
over 6 to 30	± 0.5
over 30 to 120	± 0.8
over 120 to 400	± 1.2

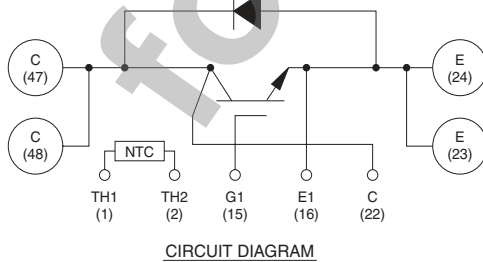

ABSOLUTE MAXIMUM RATINGS (T_j = 25°C, unless otherwise specified)

INVERTER PART

Symbol	Parameter	Conditions	Rating	Unit
V _{CES}	Collector-emitter voltage	G-E Short	1200	V
V _{GES}	Gate-emitter voltage	C-E Short	±20	
I _C	Collector current	DC, T _c = 88°C (Note. 1)	400	A
I _{CRM}		Pulse (Note. 4)	800	
P _C	Maximum collector dissipation	T _c = 25°C (Note. 1, 5)	2450	W
I _E (Note.3)	Emitter current	T _c = 25°C (Note. 1)	400	A
I _{ERM} (Note.3)	(Free wheeling diode forward current)	Pulse (Note. 4)	800	
T _j	Junction temperature		-40 ~ +150	°C
T _{stg}	Storage temperature		-40 ~ +125	
V _{iso}	Isolation voltage	Terminals to base plate, f = 60Hz, AC 1 minute	2500	V _{rms}
—	Base plate flatness	On the centerline X, Y (Note. 8)	±0 ~ +100	μm
—	Torque strength	Main terminals M6 screw	3.5 ~ 4.5	N·m
—	Torque strength	Mounting M5 screw	2.5 ~ 3.5	
—	Weight	(Typical)	330	g

Note. 8: The base plate flatness measurement points are in the following figure.

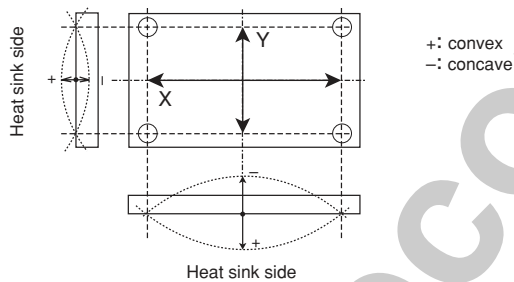

CM400HX-24A

HIGH POWER SWITCHING USE

ELECTRICAL CHARACTERISTICS (T_j = 25°C, unless otherwise specified)

INVERTER PART

Symbol	Parameter	Conditions	Limits			Unit	
			Min.	Typ.	Max.		
ICES	Collector cutoff current	V _{CE} = V _{CES} , V _{GE} = 0V	—	—	1	mA	
V _{GE(th)}	Gate-emitter threshold voltage	I _C = 40mA, V _{CE} = 10V	6	7	8	V	
I _{GES}	Gate leakage current	±V _{GE} = V _{GES} , V _{CE} = 0V	—	—	0.5	μA	
V _{CE(sat)}	Collector-emitter saturation voltage	I _C = 400A, V _{GE} = 15V (Note. 6)	T _j = 25°C	—	2.0	2.6	V
			T _j = 125°C	—	2.2	—	
		I _C = 400A, V _{GE} = 15V	Chip	—	1.9	—	
C _{ies}	Input capacitance	V _{CE} = 10V V _{GE} = 0V	(Note. 6)	—	—	66	nF
C _{oes}	Output capacitance			—	—	6.0	
C _{res}	Reverse transfer capacitance			—	—	1.3	
Q _G	Total gate charge	V _{CC} = 600V, I _C = 400A, V _{GE} = 15V		—	2000	—	nC
t _{d(on)}	Turn-on delay time	V _{CC} = 600V, I _C = 400A		—	—	660	ns
t _r	Turn-on rise time	V _{GE} = ±15V, R _G = 0.75Ω		—	—	190	
t _{d(off)}	Turn-off delay time	Inductive load		—	—	700	
t _f	Turn-off fall time			—	—	600	
t _{rr} (Note.3)	Reverse recovery time			—	—	250	
Q _{rr} (Note.3)	Reverse recovery charge	(I _E = 400A)		—	13	—	μC
V _{EC} (Note.3)	Emitter-collector voltage	I _E = 400A, V _{GE} = 0V (Note. 6)	T _j = 25°C	—	2.6	3.4	V
			T _j = 125°C	—	2.16	—	
		I _E = 400A, V _{GE} = 0V	Chip	—	2.5	—	
R _{lead}	Module lead resistance	Main terminals-chip		—	0.6	—	mΩ
R _{th(j-c)Q}	Thermal resistance	per IGBT		—	—	0.033	K/W
R _{th(j-c)R}	(Junction to case) (Note. 1)	per free wheeling diode		—	—	0.048	
R _{th(c-f)}	Contact thermal resistance (Case to heat sink) (Note. 1)	Thermal grease applied (Note. 2)		—	0.015	—	
R _{Gint}	Internal gate resistance	T _C = 25°C		2.1	3	3.9	Ω
		T _C = 125°C		4.2	6	7.8	
R _G	External gate resistance			0.75	—	7.8	

NTC THERMISTOR PART

Symbol	Parameter	Conditions	Limits			Unit
			Min.	Typ.	Max.	
R	Zero power resistance	T _C = 25°C	4.85	5.00	5.15	kΩ
ΔR/R	Deviation of resistance	T _C = 100°C, R ₁₀₀ = 493Ω	-7.3	—	+7.8	%
B(25/50)	B constant	Approximate by equation (Note. 7)	—	3375	—	K
P ₂₅	Power dissipation	T _C = 25°C	—	—	10	mW

Note.1: Case temperature (T_C), heat sink temperature (T_H) measured point is just under the chips. (Refer to the figure of the chip location.)

2: Typical value is measured by using thermally conductive grease of λ = 0.9W/(m·K).

3: I_E, I_{ERM}, V_{EC}, t_{rr} and Q_{rr} represent ratings and characteristics of the anti-parallel, emitter-collector free wheeling diode (FWDi).

4: Pulse width and repetition rate should be such that the device junction temperature (T_j) dose not exceed T_{jmax} rating.

5: Junction temperature (T_j) should not increase beyond 150°C.

6: Pulse width and repetition rate should be such as to cause negligible temperature rise.

(Refer to the figure of the test circuit for V_{CE(sat)} and V_{EC})

$$7: B(25/50) = \ln\left(\frac{R_{25}}{R_{50}}\right) \left(\frac{1}{T_{25}} - \frac{1}{T_{50}}\right)$$

R₂₅: resistance at absolute temperature T₂₅ [K]; T₂₅ = 25 [°C]+273.15 = 298.15 [K]

R₅₀: resistance at absolute temperature T₅₀ [K]; T₅₀ = 50 [°C]+273.15 = 323.15 [K]

CM400HX-24A

HIGH POWER SWITCHING USE

Chip Location (Top view)

Dimensions in mm (tolerance: ±1mm)

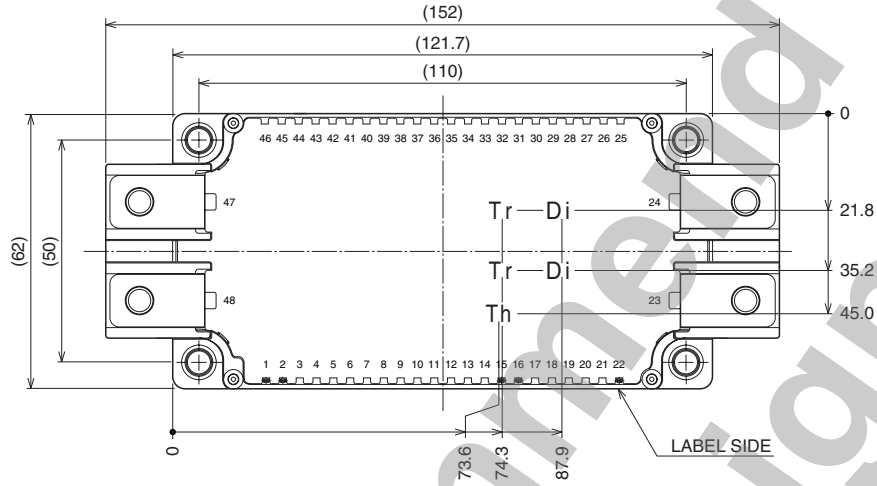

Each mark points the center position of each chip. Tr: IGBT, Di: FWDi, Th: NTC thermistor

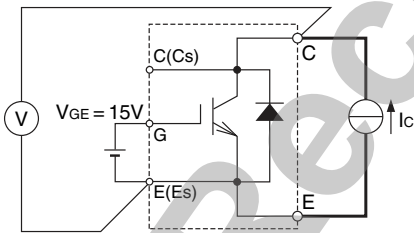

VCE(sat) test circuit

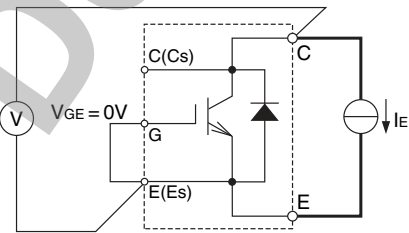

Vec test circuit

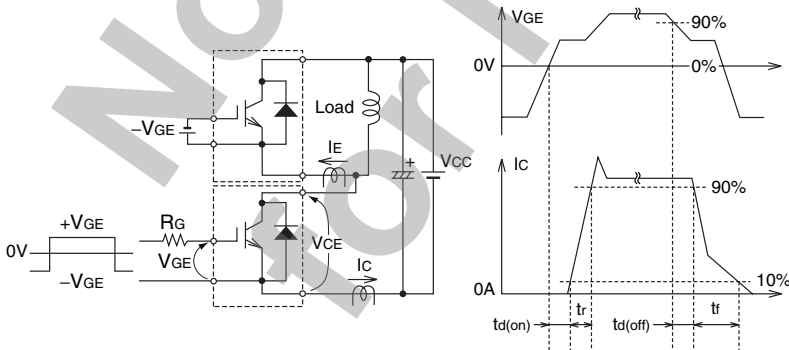

Switching time test circuit and waveforms

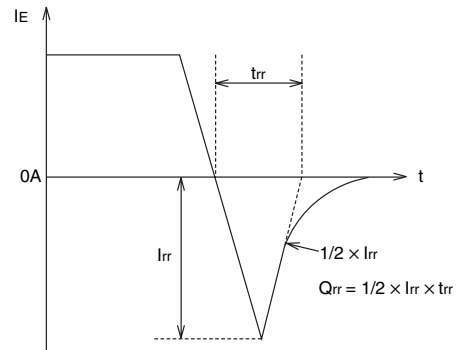

trr, Qrr test waveform

PERFORMANCE CURVES

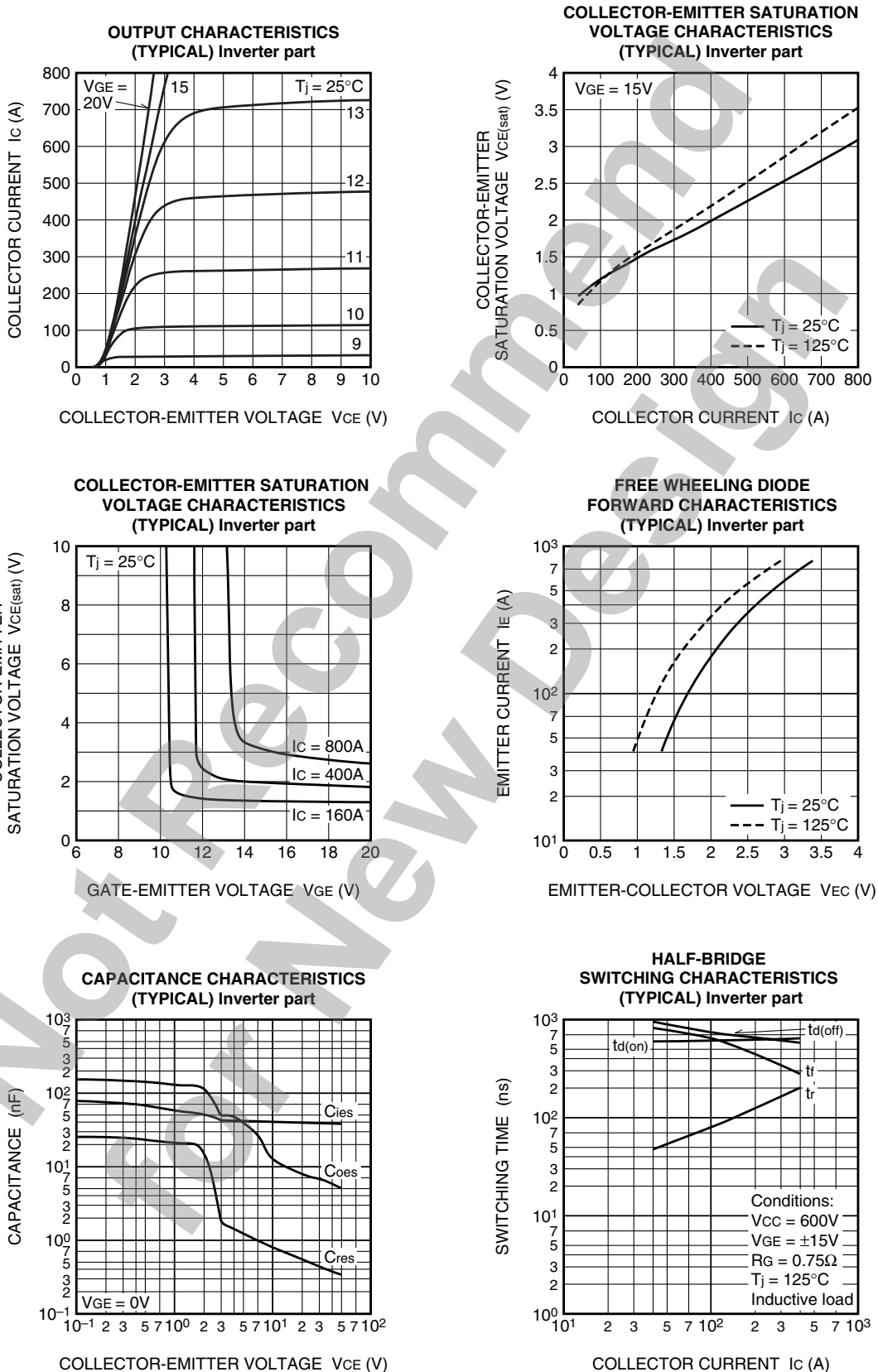

HALF-BRIDGE SWITCHING CHARACTERISTICS (TYPICAL) Inverter part

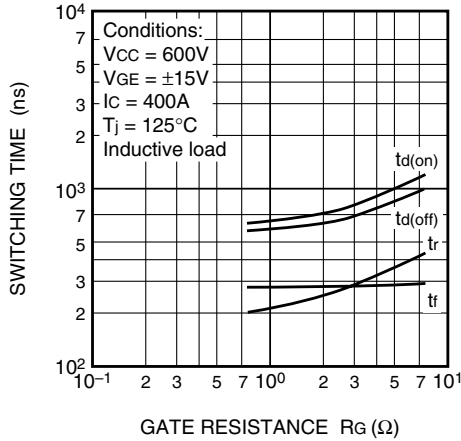

HALF-BRIDGE SWITCHING CHARACTERISTICS (TYPICAL) Inverter part

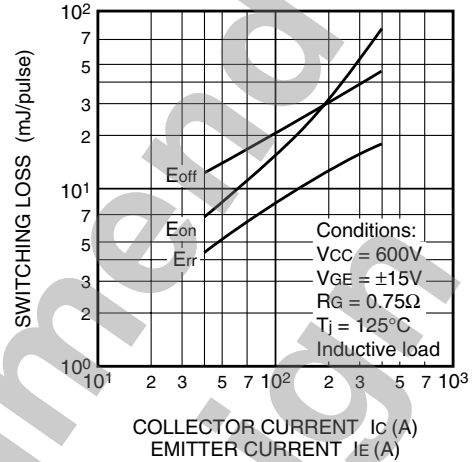

HALF-BRIDGE SWITCHING CHARACTERISTICS (TYPICAL) Inverter part

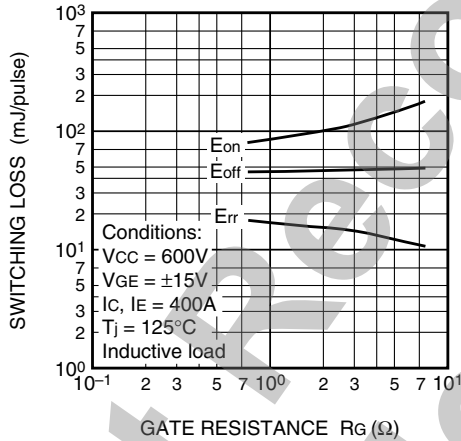

REVERSE RECOVERY CHARACTERISTICS OF FREE WHEELING DIODE (TYPICAL) Inverter part

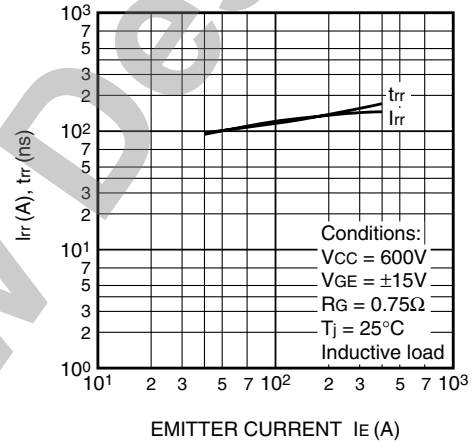

GATE CHARGE CHARACTERISTICS (TYPICAL) Inverter part

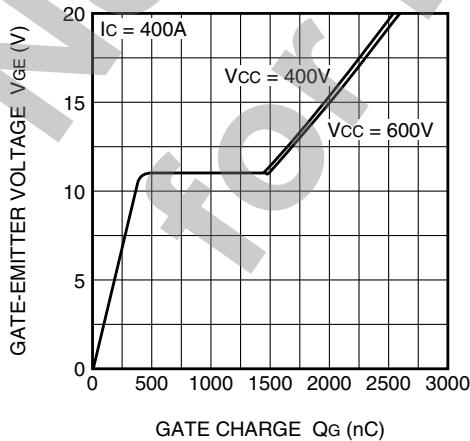

TRANSIENT THERMAL IMPEDANCE CHARACTERISTICS

