

## Current Transducer HTR 50 ... 500-SB

For the electronic measurement of currents: DC, AC, pulsed,..., with galvanic separation between the primary circuit and the secondary circuit.



$$I_{PN} = 50 \dots 500 \text{ A}$$



### Electrical data

Type	Primary nominal RMS current $I_{PN}$ (A)	Primary current, measuring range $I_{PM}$ (A)	
HTR 50-SB	50	±100	
HTR 100-SB	100	±200	
HTR 200-SB	200	±400	
HTR 300-SB	300	±600	
HTR 400-SB	400	±800	
HTR 500-SB	500	±1000	
$U_{out}$	Output voltage (Analog)	±4	V
$R_L$	Load resistance	> 10	kΩ
$U_C$	Supply voltage (±5 %)	±12 ... 15	V
$I_C$	Current consumption (max)	20	mA

### Accuracy - Dynamic performance data

$\varepsilon$	Error <sup>1)</sup> @ $I_{PN}$ , $T_A = 25^\circ\text{C}$ , @ ±12 ... 15 V (±5 %)	< ±2	%
$\varepsilon_L$	Linearity error <sup>1)</sup>	< ±1	%
		Typ	Max
$U_{OE}$	Electrical offset voltage @ $I_p = 0$ , $T_A = 25^\circ\text{C}$	±45	±65 mV
$U_{OM}$	Magnetic offset voltage @ $I_p = 0$ and specified $R_M$ , after an overload of $3 \times I_{PN}$	±10	±20 mV
$U_{OT}$	Temperature variation of $U_O$ , $T_A = -10 \dots +70^\circ\text{C}$	±70	±240 mV
$TCS$	Temperature coefficient of $S$	±140	±450 mV
$t_{D90}$	Delay time to 90 % of $I_{PN}$ <sup>2)</sup>	< 10	μs
$BW$	Frequency bandwidth (-1 dB)	DC ... 10	kHz

### General data

$T_A$	Ambient operating temperature	-10 ... +70	°C
$T_S$	Ambient storage temperature	-20 ... +85	°C
$m$	Mass	80	g
	Standards	EN 50178: 1997 <sup>3)</sup>	
		UL 508: 2013	

**Notes:** <sup>1)</sup> Excludes the electrical offset

<sup>2)</sup> For a  $di/dt = 50 \text{ A}/\mu\text{s}$

<sup>3)</sup> Regarding compliance towards IEC 61000-4-3 (EN61000-6-2 (2005)): Output is above to 7.7 % of  $U_{SN}$  between 80 MHz and 1 GHz with a field intensity of 10 [V/m].

### Features

- Open loop Hall effect transducer
- Busbar mounting or panel mounting
- Insulating plastic case recognized according to UL 94-V0.

### Advantages

- Low power consumption
- Split core easy for mounting
- High insulation between the primary and the secondary circuit
- Through-hole, no insertion losses.

### Applications

- Power supplies for TELECOM (monitoring & measuring)
- Uninterruptible Power Supplies (UPS)
- Switched Mode Power Supplies (SMPS)
- Electrical chemistry
- Chopper
- Battery supplied applications.

### Application domain

- Industrial.

## Current Transducer HTR 50 ... 500-SB

### Insulation coordination

$U_d$	RMS voltage for AC insulation test, 50 Hz, 1 min	3	kV
$U_{Ni}$	Impulse withstand voltage 1.2/50 $\mu$ s	> 6	kV
$U_e$	Partial discharge extinction RMS voltage	> 1.5	kV
		Min	
$d_{Cp}$	Creepage distance	28.1	mm
$d_{Cl}$	Clearance	17.1	mm
$CTI$	Comparative tracking index (group IIIa)	225	

### Applications examples

According to EN 50178 and IEC 61010-1 standards and following conditions:

- Over voltage category OV 3
- Pollution degree PD2
- Non-uniform field

	EN 50178	IEC 61010-1
$d_{Cp}, d_{Cl}, U_{Ni}$	Rated insulation voltage	Nominal voltage
Basic insulation	1000 V	1000 V
Reinforced insulation	500 V	500 V

### Safety

This transducer must be used in limited-energy secondary circuits according to IEC 61010-1.



This transducer must be used in electric/electronic equipment with respect to applicable standards and safety requirements in accordance with the manufacturer's operating instructions.



Caution, risk of electrical shock

When operating the transducer, certain parts of the module can carry hazardous voltage (eg. primary busbar, power supply).

Ignoring this warning can lead to injury and/or cause serious damage.

This transducer is a build-in device, whose conducting parts must be inaccessible after installation.

A protective housing or additional shield could be used.

Main supply must be able to be disconnected.

## Dimensions HTR 50 ... 500-SB (in mm)

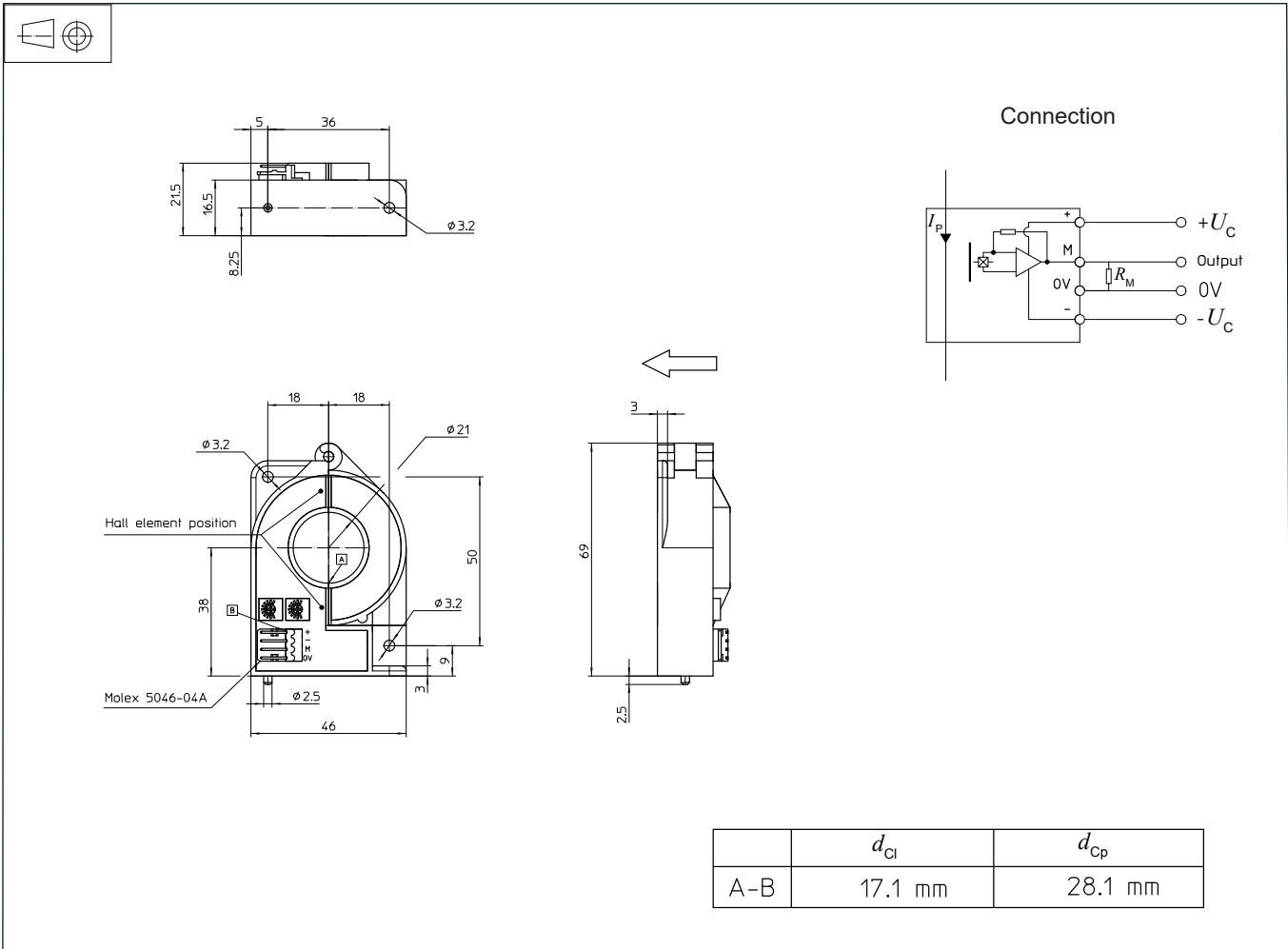

### Mechanical characteristics

- General tolerance  $\pm 1$  mm
- Primary through hole  $\varnothing 21$  mm
- Fastening 2 holes  $\varnothing 3.2$  mm
- Distance between holes axes  $50 \times 36$  mm
- or 1 hole  $\varnothing 3.2$  mm and 1 spigot  $\varnothing 2.5$  mm
- Distance between hole and spigot axes 36 mm
- Connection of secondary Molex 5046-04A

### Remarks

- $U_{out}$  is positive when  $I_P$  flows in the direction of the arrow.
- Temperature of the primary conductor should not exceed 100 °C.
- Installation of the transducer must be done unless otherwise specified on the datasheet, according to LEM Transducer Generic Mounting Rules. Please refer to LEM document N°ANE120504 available on our Web site: <https://www.lem.com/en/file/3137/download/>.
- The retrace busbar and primary conductor elbow must be located at least at 2.5 mm  $\times$  window length more far away from the transducer case.
- Dynamic performances are best with a primary busbar completely filling the primary aperture.
- This is a standard model. For different versions (supply voltages, turns ratios, unidirectional measurements...), please contact us.