

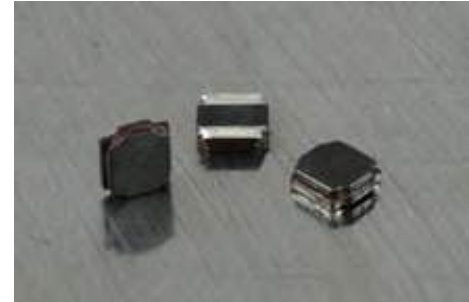

SMD SHIELDED POWER CHIP INDUCTOR

PCSV62

Dimensions: Inches
(mm)

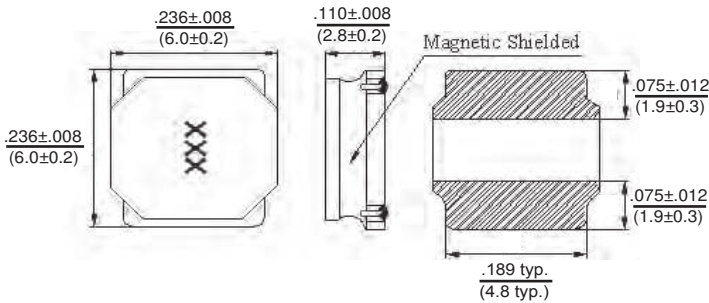

Allied Part Number	Inductance (µh)	Tolerance (%)	Test Freq. Khz, 1V	RDC (mΩ) ±30%	Isat (A) Typ.	Irms (A) Typ.	Marking
PCSV62-1R0T-RC	1.0	30	100	13	7.6	5.2	1R0
PCSV62-1R5T-RC	1.5	30	100	16	6.3	4.8	1R5
PCSV62-2R2T-RC	2.2	30	100	20	5.4	4.0	2R2
PCSV62-3R3T-RC	3.3	30	100	28	4.3	3.5	3R3
PCSV62-4R7M-RC	4.7	20	100	38	3.7	3.2	4R7
PCSV62-6R0M-RC	6.0	20	100	45	3.3	2.8	6R0
PCSV62-6R8M-RC	6.8	20	100	50	3.1	2.7	6R8
PCSV62-100M-RC	10	20	100	65	2.5	2.3	100
PCSV62-150M-RC	15	20	100	95	2.0	1.8	150
PCSV62-220M-RC	22	20	100	135	1.6	1.5	220
PCSV62-330M-RC	33	20	100	220	1.3	1.4	330
PCSV62-470M-RC	47	20	100	320	1.1	1.0	470
PCSV62-680M-RC	68	20	100	420	0.98	0.90	680
PCSV62-101M-RC	100	20	100	600	0.82	0.80	101

All specifications subject to change without notice.

Features

- Magnetically Shielded Construction
- Ultra Low Profile

Electrical

Inductance Range: 1.0µh ~ 100µh (other values being added)

Tolerance: Available in 20% & 30% as noted

Operating Temp: -55°C ~ +125°C

Isat: Current at which the Inductance will drop by no more than 30% of its initial value.

Irms: Based on a temp rise of ΔT = 40°C typical at 25°C Ambient.

Resistance to Soldering Heat

Pre-Heat 150°C, 1 Min.

Solder Composition: Sn/Ag3.0/Cu0.5

Solder Temp: 260°C +/- 5°C for 10 sec

Test Equipment

(L): Agilent/HP4284A + Agilent/HP16334A

(RDC): Chroma MilliOhm Meter Mode16502

Current: Isat: HP4284A + HP42841A

Irms: Agilent 6641 System DC Power Supply

Physical

Packaging: 1500 per Tape and reel

Marking: EIA Inductance Code