





# SPECIFICATIONS

**CUSTOMER** : \_\_\_\_\_  
**MODEL NO.** : **GFTO024KA240320**  
**VERSION** : **B**  
**DATE** : **2023.03.02**  
**CERTIFICATION** : **ROHS**

Customer Sign	Approved By	Prepared By	Prepared By
			

晶發科技股份有限公司  
GI FAR TECHNOLOGY CO., LTD.

新北市樹林區東豐街 81 號

No. 81, Dongfeng St, Shulin District, 238034, New Taipei City, Taiwan, R.O.C.

TEL: +886-2-8684-1188 FAX: +886-2-8684-8532





# CONTENTS

<b>1. SPECIFICATIONS</b>	<b>4</b>
1.1 Features	4
1.2 Mechanical Specifications	4
1.3 Absolute Maximum Ratings	5
1.4 DC Electrical Characteristics	5
1.5 Optical Characteristics	6
1.6 Backlight Characteristics	8
<b>2. MODULE STRUCTURE</b>	<b>9</b>
2.1 Block Diagram	9
2.2 Interface Pin Description	10
2.3 Refer Initial code	11
2.4 Timing Characteristics	15
<b>3. QUALITY ASSURANCE SYSTEM</b>	<b>19</b>
3.1 Quality Assurance Flow Chart	19
3.2 Inspection Specification	21
<b>4. RELIABILITY TEST</b>	<b>28</b>
4.1 Reliability Test Condition	28
<b>5. PRECAUTION RELATING PRODUCT HANDLING</b>	<b>29</b>
5.1 Safety	29
5.2 Handling	29
5.3 Storage	29
5.4 Terms of Warranty	29
<b>6. Appendix</b>	<b>30</b>
6.1 LCM Drawing	30
6.2 Package Drawing	31



# 1.SPECIFICATIONS

## 1.1 Features

### Main LCD Panel

Item	Standard Value
Display Resolution	240 * (R · G · B) * 320 Dots
Display Mode	a-Si TFT , Normally White TN mode , Transmissive
Screen size(inch)	2.4" (Diagonal)
Viewing Direction	12 O'clock
Color configuration	R.G.B. vertical stripe
Backlight	White LED
Interface	RGB CPU SPI PARALEL Interface
Other(controller / driver IC)	ILI9341V
RoHS	YES

## 1.2 Mechanical Specifications

Item	Standard Value	Unit
Outline Dimension	42.92 (W) *60.26 (L) * 2.6 (H)	mm

### LCD Panel

Item	Standard Value	Unit
Active Area (LCD)	36.72 (W) * 48.96 (L)	mm

Note: For detailed information please refer to LCM drawing.



### 1.3 Absolute Maximum Ratings

#### Module

Item	Symbol	Condition	Min.	Max.	Unit
System Power Supply Voltage	VDD	-	-0.3	+4.0	V
	VGH-VSS	-	-0.3	+17.0	V
	VSS-VGL	-	0	12.0	V
Operating Temperature	T <sub>OP</sub>	-	-20	+70	°C
Storage Temperature	T <sub>ST</sub>	-	-30	+80	°C

### 1.4 DC Electrical Characteristics

#### Module

V<sub>CC</sub> = 1.65~3.3V, T<sub>a</sub> = 25°C

Item	Symbol	Condition	Min.	Typ.	Max.	Unit
Interface operation voltage	VDD	I/O supply voltage	2.5	2.8	3.3	V
Input High Voltage	V <sub>IH</sub>	-	0.7*VDD	-	VDD	V
Input Low Voltage	V <sub>IL</sub>	-	GND	-	0.3*VDD	V
Output High Voltage	V <sub>OH</sub>	IOH=-0.1mA	0.8*VDD	-	VDD	V
Output Low Voltage	V <sub>OL</sub>	IOL=0.1mA	GND	-	0.2*VDD	V
Supply Current	IDD	VDD= 2.8V, Pattern= Black*1	-	10	-	mA

Note1 : Maximum current display.



### 1.5 Optical Characteristics

#### TFT LCD Panel

VDD = 2.8V, Ta=25°C

Item	Symbol	Condition	Min.	Typ.	Max.	unit		
Response time	Tr + Tf	Ta = 25°C θX, θY = 0°	-	30	-	ms	Note2	
Viewing angle	Top	CR ≥ 10	-	45	-	Deg.	Note4	
	Bottom		-	20	-			
	Left		-	45	-			
	Right		-	45	-			
Contrast ratio	CR		-	250	-	-	Note3	
Color of CIE Coordinate (With B/L)	White	Ta = 25°C θX, θY = 0°	X	0.25	0.30	0.35	-	Note1
			Y	0.25	0.30	0.35		
	Red		X	0.54	0.59	0.64		
			Y	0.28	0.33	0.38		
	Green		X	0.27	0.33	0.38		
			Y	0.55	0.60	0.65		
	Blue		X	0.10	0.15	0.20		
			Y	0.03	0.08	0.13		
Average Brightness Pattern=white display (With B/L)	IV	IF= 40mA	400	-	-	cd/m <sup>2</sup>	Note1	
Uniformity(With B/L)	ΔB	IF= 40mA	80			%		

Note1:

1 :  $\Delta B = B(\min) / B(\max) \times 100\%$

2 : Measurement Condition for Optical Characteristics:

a : Environment: 25°C±5°C / 60±20%R.H, no wind, dark room below 10 Lux at typical lamp current and typical operating frequency.

b : Measurement Distance: 500 ± 50 mm, (θ= 0°).

c : Equipment: TOPCON BM-7 fast, (field 1°), after 10 minutes operation.

d : The uncertainty of the C.I.E coordinate measurement ±0.01, Average Brightness ± 4%.

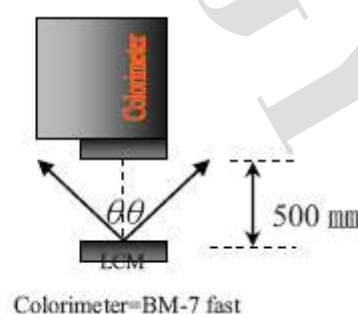



Note2: Definition of response time:

The output signals of photo detector are measured when the input signals are changed from "black" to "white"(falling time) and from "white" to "black"(rising time), respectively. The response time is defined as the time interval between the 10% and 90% of Amplitudes.

Refer to figure as below:

Normally White

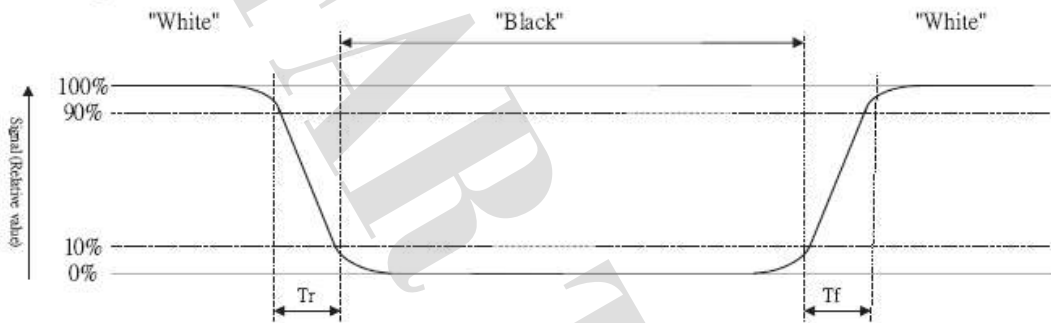

Normally Black

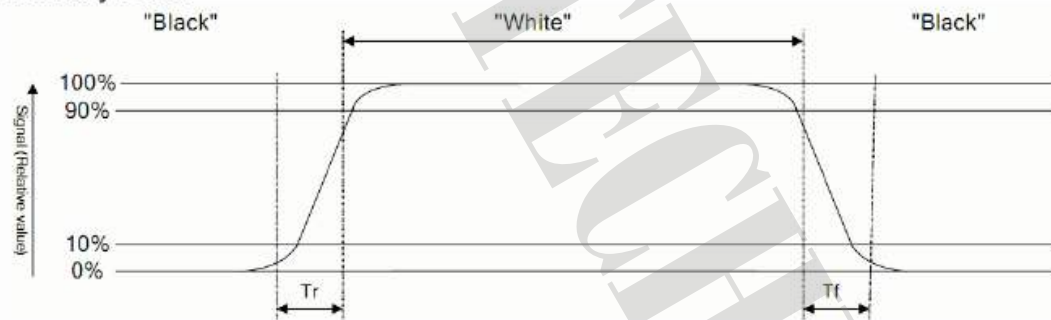

Note3: Definition of contrast ratio:

Contrast ratio is calculated with the following formula

$$\text{Contrast ratio (CR)} = \frac{\text{Photo detector output when LCD is at "White" state}}{\text{Photo detector output when LCD is at "Black" state}}$$

Note4: Definition of viewing angle:

Refer to figure as below:

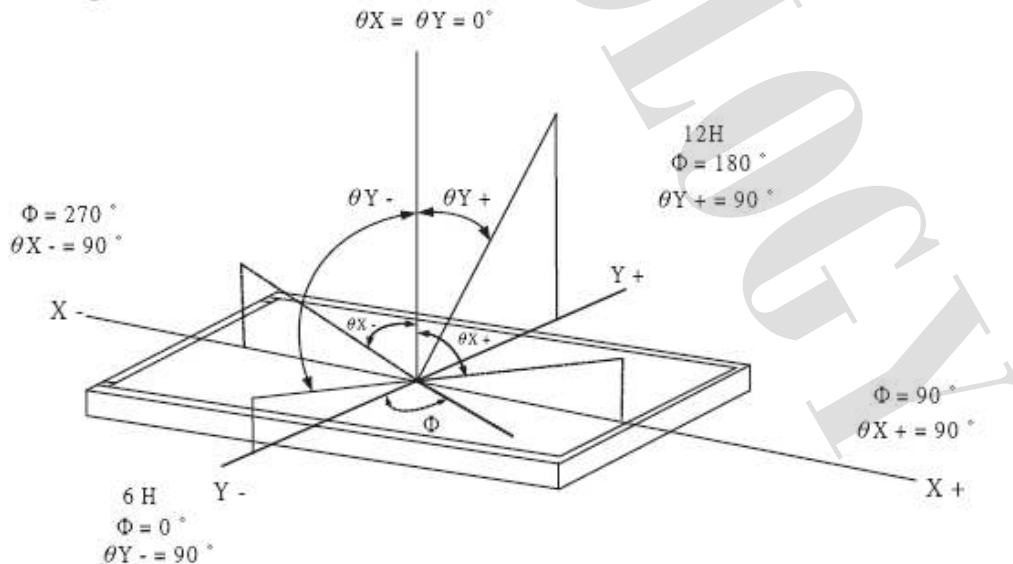



## 1.6 Backlight Characteristics

### Electrical / Optical Characteristics

Item	Symbol	Conditions	Min.	Typ.	Max.	Unit
Forward Voltage	VF	IF=40mA	5.6	6.0	6.6	V
Average Brightness (without LCD)	IV	IF=40mA	8000	10000	-	cd/m <sup>2</sup>
Color of CIE Coordinate (without LCD)	X		0.26	0.29	0.32	-
	Y		0.26	0.29	0.32	
Color	White					

\*1: This value will be changed while mass production.

\*2:  $\Delta B = B(\min)/B(\max) * 100\%$

B/L Internal Circuit Diagram







## 2. MODULE STRUCTURE

### 2.1 Block Diagram

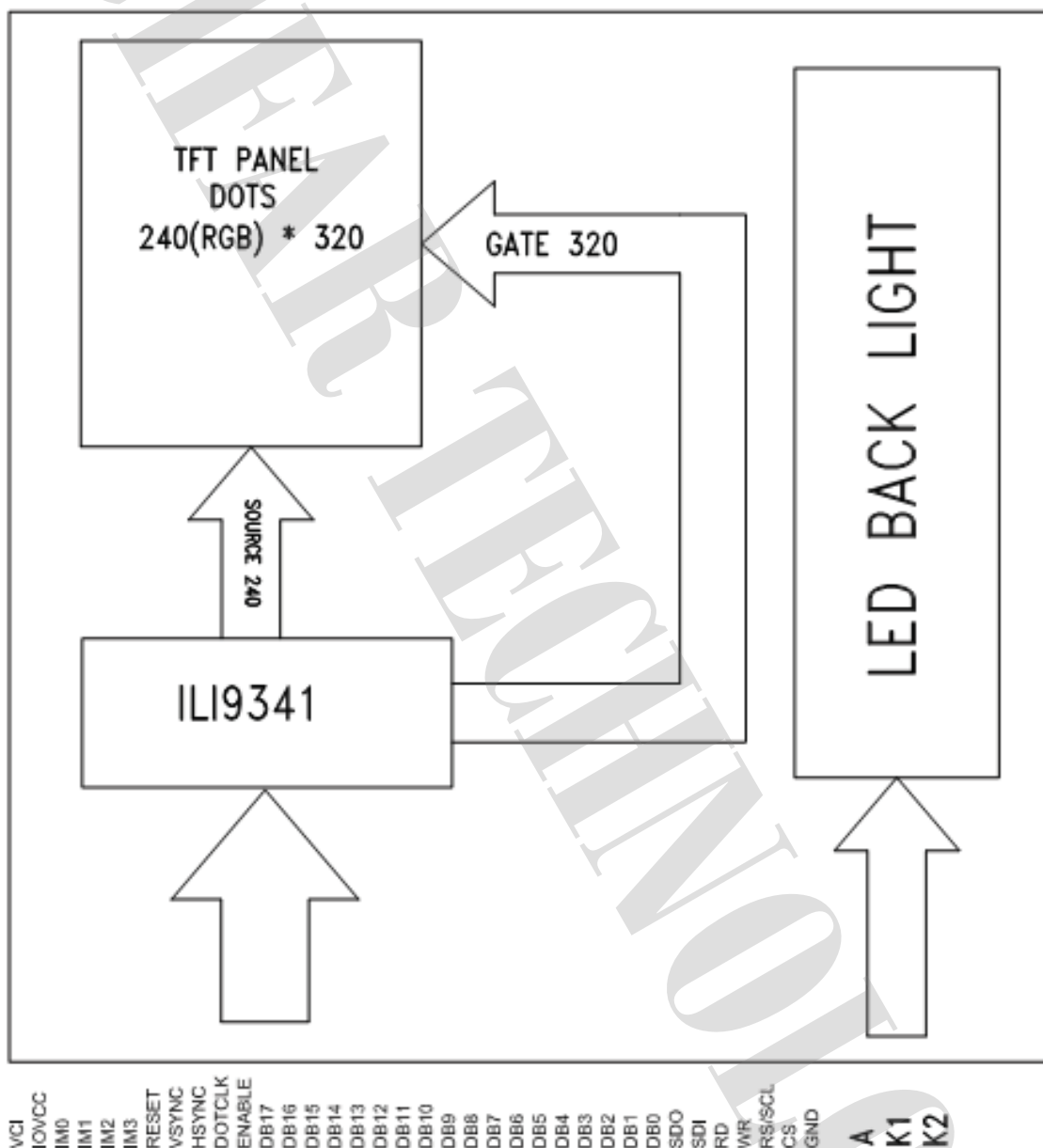



## 2.2 Interface Pin Description

Pin	Symbol	Function	Remark
1	VCI	Power Supply for Logic and Booster	-
2	IOVCC	I/O Interface Supply voltage	-
3	IM0	MCU Interface Select Pin	-
4	IM1	MCU Interface Select Pin	-
5	IM2	MCU Interface Select Pin	-
6	IM3	MCU Interface Select Pin	-
7	RESET	Hardware reset	-
8	VSYNC	Vertical synchronous signal Fix to the GND level when not in use.	-
9	HSYNC	Horizontal synchronous signal Fix to the GND level when not in use.	-
10	DOTCLK	Dot Clock Signal In RGB I/F Fix to the GND level when not in use	-
11	ENABLE	Data enable single in RGB I/F Low: Select (access enabled) High: Not select (access inhibited) Fix to either IOVcc or GND level when not in use.	-
12	DB17	Date Bit	-
13	DB16	Date Bit	-
14	DB15	Date Bit	-
15	DB14	Date Bit	-
16	DB13	Date Bit	-
17	DB12	Date Bit	-
18	DB11	Date Bit	-
19	DB10	Date Bit	-
20	DB9	Date Bit	-
21	DB8	Date Bit	-
22	DB7	Date Bit	-
23	DB6	Date Bit	-
24	DB5	Date Bit	-
25	DB4	Date Bit	-
26	DB3	Date Bit	-
27	DB2	Date Bit	-
28	DB1	Date Bit	-
29	DB0	Date Bit	-
30	SDO	Series data output pin Let SDO as floating when not used.	-
31	SDI	Series data input pin	-
32	RD	Read enable in 80-system interface mode Fix to either IOVcc or GND level when not in use	-
33	WR	Write Signal Fix to either IOVcc or GND level when not in use. SPI Mode: Synchronizing clock signal in SPI mode.	-
34	RS/SCL	Register Index or Register Command Select Fix to either IOVcc or GND level when not in use.	-
35	CS	Chip Select Pin Fix to the GND level when not in use.	-
36	GND	Ground	-
37	LED A	Anode for LED	-
38	LED K1	Cathode for LED	-
39	LED K2	Cathode for LED	-
40	DUMMY	NC	-
41	DUMMY	NC	-
42	DUMMY	NC	-
43	DUMMY	NC	-
44	DUMMY	NC	-
45	DUMMY	NC	-



### 2.2.1 Application Notes:

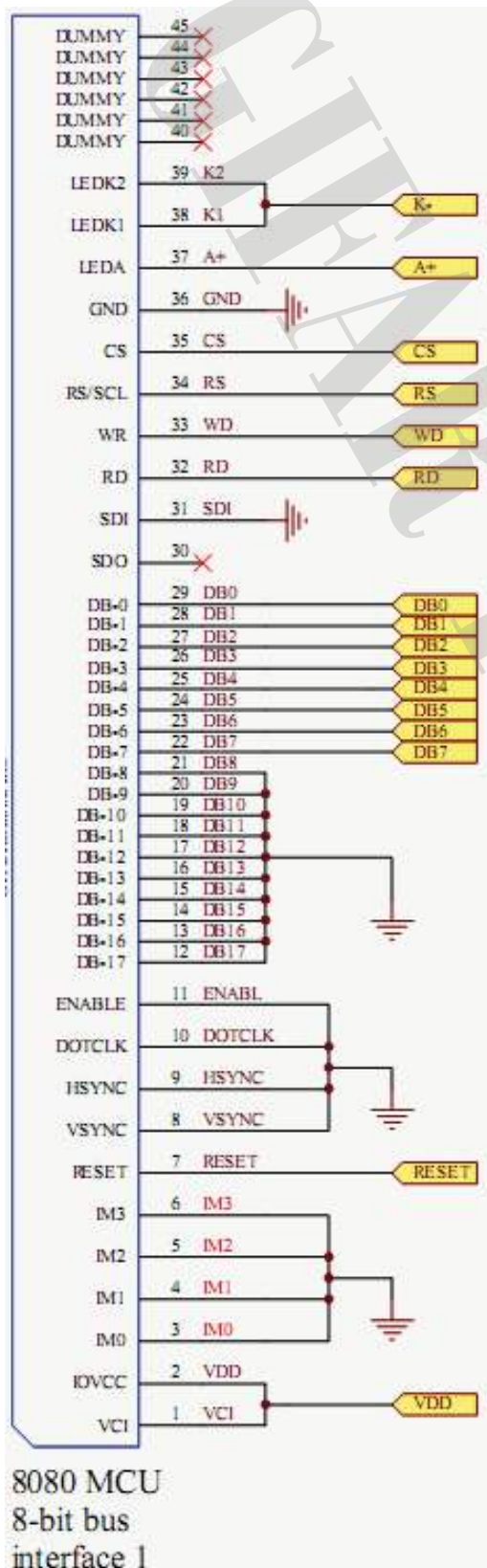



### 2.3 Refer Initial code:

```
//Initial-----  
void Initial_Main(void)           // For   ILI9341  
{  
    WriteCOM_Main(0xCF);  
    WriteDAT_Main(0x00);  
    WriteDAT_Main(0xD9);  
    WriteDAT_Main(0x30);  
  
    WriteCOM_Main(0xED);  
    WriteDAT_Main(0x64);  
    WriteDAT_Main(0x03);  
    WriteDAT_Main(0x12);  
    WriteDAT_Main(0x81);  
  
    WriteCOM_Main(0xE8);  
    WriteDAT_Main(0x85);  
    WriteDAT_Main(0x00);  
    WriteDAT_Main(0x78);  
  
    WriteCOM_Main(0xCB);  
    WriteDAT_Main(0x39);  
    WriteDAT_Main(0x2C);  
    WriteDAT_Main(0x00);  
    WriteDAT_Main(0x34);  
    WriteDAT_Main(0x02);  
  
    WriteCOM_Main(0xF7);  
    WriteDAT_Main(0x20);  
    WriteCOM_Main(0xEA);  
    WriteDAT_Main(0x00);  
    WriteDAT_Main(0x00);  
  
    WriteCOM_Main(0xC0);//Power control  
    WriteDAT_Main(0x21);//VRH[5:0] //0x1B  
  
    WriteCOM_Main(0xC1);//Power control  
    WriteDAT_Main(0x12);//SAP[2:0];BT[3:0]
```



```
WriteCOM_Main(0xC5); //VCOM Control
```

```
WriteDAT_Main(0x32);
```

```
WriteDAT_Main(0x3C);
```

```
WriteCOM_Main(0xC7); //VCOM Control2
```

```
WriteDAT_Main(0xa3); //0x9D
```

```
WriteCOM_Main(0x36); //Memory access Control
```

```
WriteDAT_Main(0x08);
```

```
WriteCOM_Main(0x3A); //Memory access Control
```

```
WriteDAT_Main(0x55);
```

```
WriteCOM_Main(0xB1);
```

```
WriteDAT_Main(0x00);
```

```
WriteDAT_Main(0x1B);
```

```
WriteCOM_Main(0xB6); //Display Function
```

```
WriteDAT_Main(0x0a);
```

```
WriteDAT_Main(0xa2);
```

```
WriteCOM_Main(0xF6);
```

```
WriteDAT_Main(0x01);
```

```
WriteDAT_Main(0x30);
```

```
WriteCOM_Main(0xF2); //3Gamma Function Disable
```

```
WriteDAT_Main(0x00);
```

```
WriteCOM_Main(0x26); //Gamma Curve select
```

```
WriteDAT_Main(0x01);
```

```
//-----set gamma-----
```

```
WriteCOM_Main(0xe0); //set gamma
```

```
WriteDAT_Main(0x0f);
```

```
WriteDAT_Main(0x1c);
```

```
WriteDAT_Main(0x19);
```

```
WriteDAT_Main(0x08);
```



```
WriteDAT_Main(0x0b);
WriteDAT_Main(0x04);
WriteDAT_Main(0x4b);
WriteDAT_Main(0x64);
WriteDAT_Main(0x3e);
WriteDAT_Main(0x09);
WriteDAT_Main(0x15);
WriteDAT_Main(0x08);
WriteDAT_Main(0x16);
WriteDAT_Main(0x0D);
WriteDAT_Main(0x04);

WriteCOM_Main(0xe1); //set gamma
WriteDAT_Main(0x00);
WriteDAT_Main(0x1a);
WriteDAT_Main(0x1e);
WriteDAT_Main(0x03);
WriteDAT_Main(0x0f);
WriteDAT_Main(0x03);
WriteDAT_Main(0x35);
WriteDAT_Main(0x23);
WriteDAT_Main(0x45);
WriteDAT_Main(0x04);
WriteDAT_Main(0x0c);
WriteDAT_Main(0x0b);
WriteDAT_Main(0x2b);
WriteDAT_Main(0x2e);
WriteDAT_Main(0x05);
WriteCOM_Main(0x11); //exit sleep
Delay(120);
WriteCOM_Main(0x29); //Display on
}
```









## 4-LINE SPI

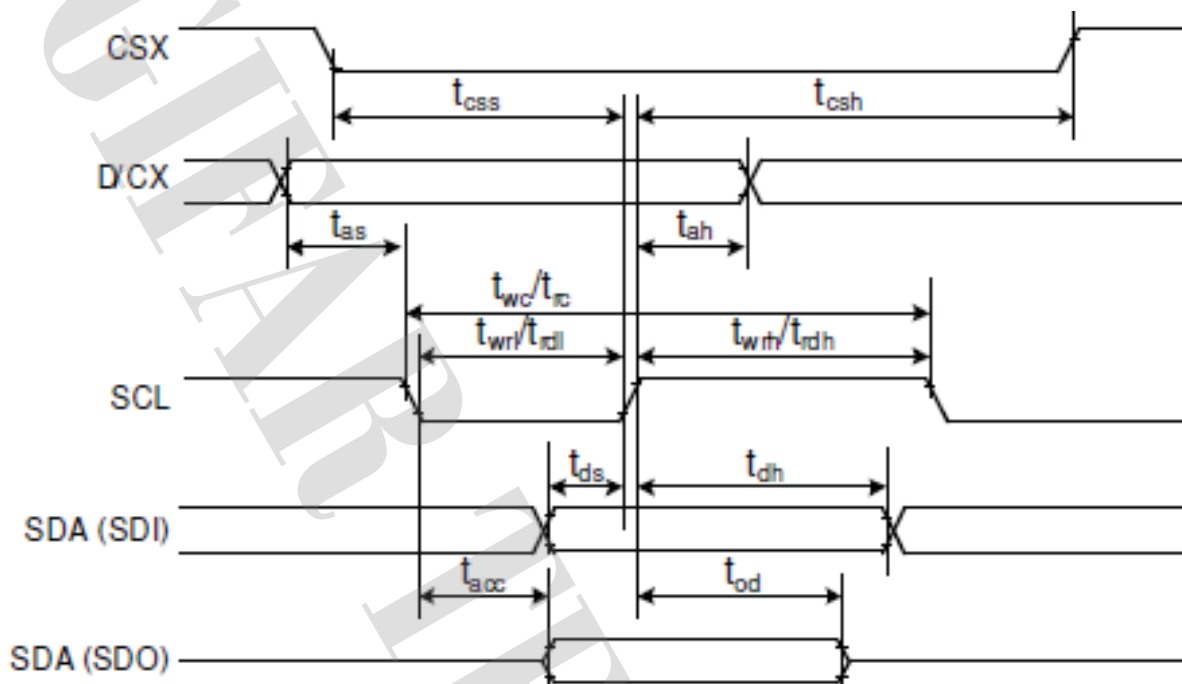

Signal	Symbol	Parameter	min	max	Unit	Description
CSX	$t_{css}$	Chip select time (Write)	40	-	ns	
	$t_{csh}$	Chip select hold time (Read)	40	-	ns	
SCL	$t_{wc}$	Serial clock cycle (Write)	100	-	ns	
	$t_{wrh}$	SCL "H" pulse width (Write)	40	-	ns	
	$t_{wrl}$	SCL "L" pulse width (Write)	40	-	ns	
	$t_{rc}$	Serial clock cycle (Read)	150	-	ns	
	$t_{rdh}$	SCL "H" pulse width (Read)	60	-	ns	
	$t_{rdl}$	SCL "L" pulse width (Read)	60	-	ns	
D/CX	$t_{as}$	D/CX setup time	10	-		
	$t_{ah}$	D/CX hold time (Write / Read)	10	-		
SDA / SDI (Input)	$t_{ds}$	Data setup time (Write)	30	-	ns	
	$t_{dh}$	Data hold time (Write)	30	-	ns	
SDA / SDO (Output)	$t_{acc}$	Access time (Read)	10	-	ns	For maximum CL=30pF
	$t_{od}$	Output disable time (Read)	10	50	ns	For minimum CL=8pF



## RGB INTERFACE

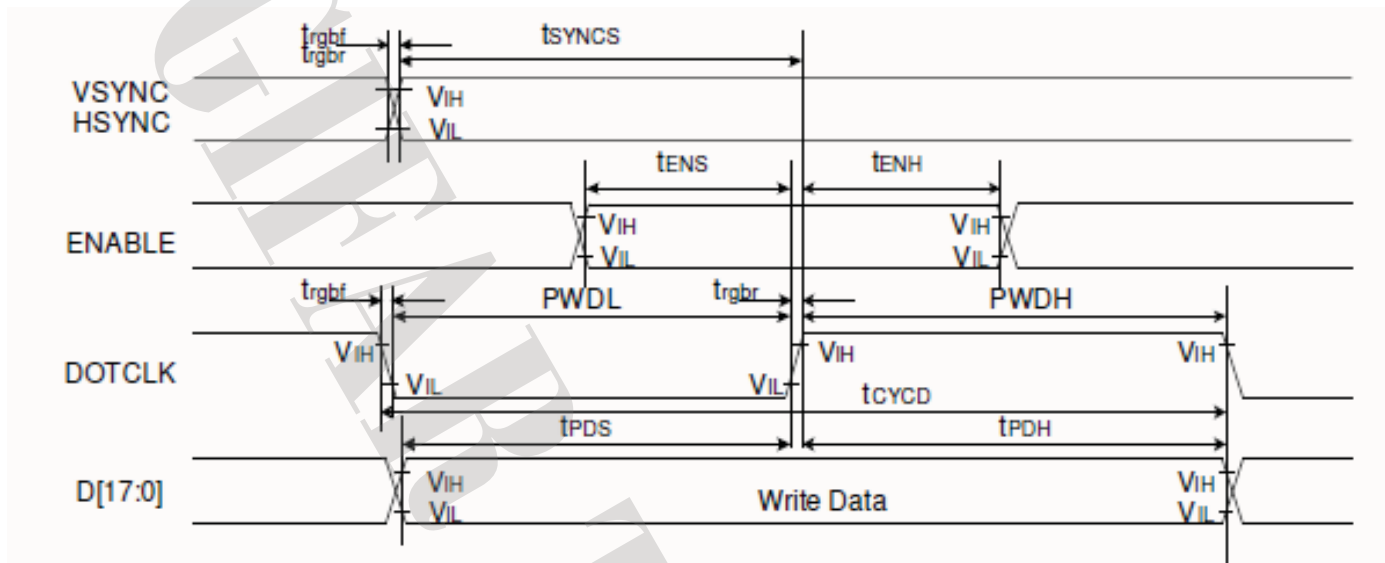

Signal	Symbol	Parameter	min	max	Unit	Description
VSYNC / HSYNC	$t_{SYNCS}$	VSYNC/HSYNC setup time	15	-	ns	18/16-bit bus RGB interface mode
	$t_{SYNCH}$	VSYNC/HSYNC hold time	15	-	ns	
DE	$t_{ENS}$	DE setup time	15	-	ns	
	$t_{ENH}$	DE hold time	15	-	ns	
D[17:0]	$t_{POS}$	Data setup time	15	-	ns	
	$t_{PDH}$	Data hold time	15	-	ns	
DOTCLK	$PWDH$	DOTCLK high-level period	15	-	ns	
	$PWDL$	DOTCLK low-level period	15	-	ns	
	$t_{CYCD}$	DOTCLK cycle time	100	-	ns	
	$t_{rgr}, t_{grb}$	DOTCLK, HSYNC, VSYNC rise/fall time	-	15	ns	
VSYNC / HSYNC	$t_{SYNCS}$	VSYNC/HSYNC setup time	15	-	ns	6-bit bus RGB interface mode
	$t_{SYNCH}$	VSYNC/HSYNC hold time	15	-	ns	
DE	$t_{ENS}$	DE setup time	15	-	ns	
	$t_{ENH}$	DE hold time	15	-	ns	
D[17:0]	$t_{POS}$	Data setup time	15	-	ns	
	$t_{PDH}$	Data hold time	15	-	ns	
DOTCLK	$PWDH$	DOTCLK high-level pulse period	15	-	ns	
	$PWDL$	DOTCLK low-level pulse period	15	-	ns	
	$t_{CYCD}$	DOTCLK cycle time	100	-	ns	
	$t_{rgr}, t_{grb}$	DOTCLK, HSYNC, VSYNC rise/fall time	-	15	ns	



### 3. QUALITY ASSURANCE SYSTEM

#### 3.1 Quality Assurance Flow Chart

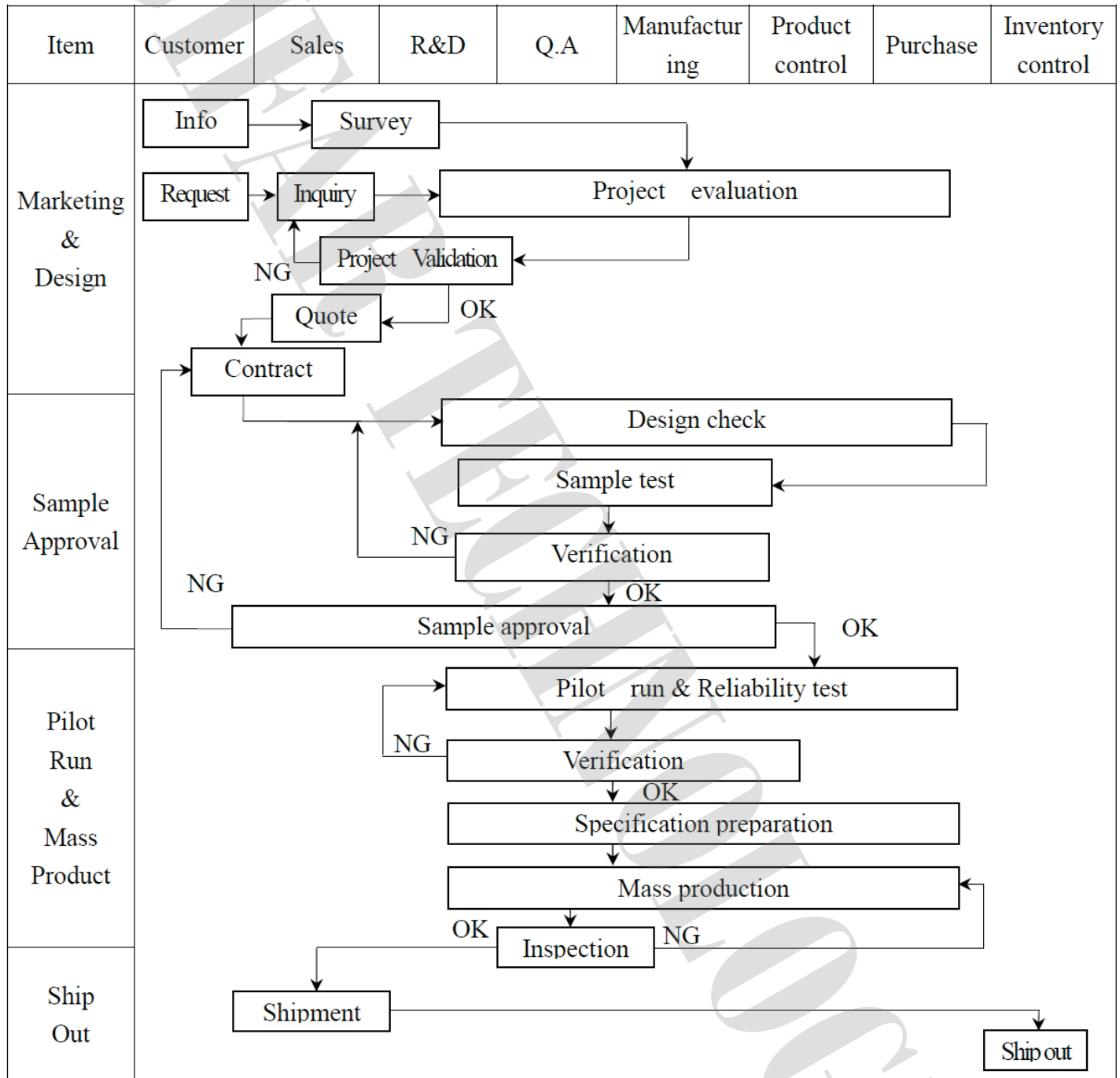



Item	Customer	Sales	R&D	Q.A	Manufacturing	Product control	Purchase	Inventory control
Sales Service	<pre> graph TD     Info[Info] --&gt; Claim[Claim]     Claim --&gt; Analysis[Failure analysis]     Claim --&gt; Report[Analysis report]     Analysis --&gt; Action[Corrective action]     Action --&gt; Tracking[Tracking]         </pre>							
Q.A Activity	1. ISO 9001 Maintenance Activities 3. Equipment calibration 5. Standardization Management				2. Process improvement proposal 4. Education And Training Activities			



### 3.2. Inspection Specification

- ◆Scope : The document shall be applied to TFT-LCD Module for less than 3.5"
- ◆Inspection Standard : MIL-STD-105E Table Normal Inspection Single Sampling Level II .
- ◆Equipment : Gauge 、 MIL-STD 、 Sample
- ◆Defect Level : Major Defect AQL : 0.4 ; Minor Defect AQL : 1.5
- ◆OUT Going Defect Level : Sampling.
- ◆Standard of the product appearance test :

#### a. Manner of appearance test :

- (1). The test best be under 20W×2 fluorescent light , and distance of view must be at 30 cm.
- (2). The test direction is base on about around 45° of vertical line.

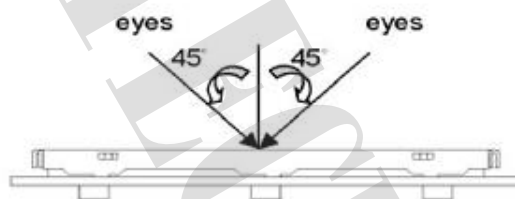

#### (3). Definition of area.

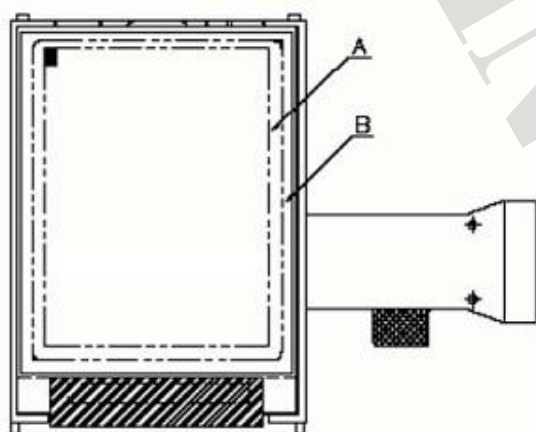

A area : viewing area

B area : Outside of viewing area

#### (4). Standard of inspection : (Unit : mm)



◆ Specification For TFT-LCD Module Less Than 3.5" :

NO	Item	Criterion	Level												
01	Product condition	1. 1 The part number is inconsistent with work order of production.	Major												
		1. 2 Mixed product types.	Major												
		1. 3 Assembled in inverse direction.	Major												
02	Quantity	2. 1 The quantity is inconsistent with work order of production.	Major												
03	Outline dimension	3. 1 Product dimension and structure must conform to structure diagram.	Major												
04	Electrical Testing	4. 1 Missing line character and icon.	Major												
		4. 2 No function or no display.	Major												
		4. 3 Display malfunction.	Major												
		4. 4 LCD viewing angle defect.	Major												
		4. 5 Current consumption exceeds product specifications.	Major												
05	<b>Dot defect</b>  (Bright dot 、 Dark dot)  On -display	<table border="1"> <thead> <tr> <th></th> <th>Item</th> <th>Acceptance (Q'ty)</th> </tr> </thead> <tbody> <tr> <td rowspan="4">Dot Defect</td> <td>Bright Dot</td> <td><math>\leq 2</math></td> </tr> <tr> <td>Dark Dot</td> <td><math>\leq 3</math></td> </tr> <tr> <td>Joint Dot</td> <td><math>\leq 2</math></td> </tr> <tr> <td>Total</td> <td><math>\leq 3</math></td> </tr> </tbody> </table>		Item	Acceptance (Q'ty)	Dot Defect	Bright Dot	$\leq 2$	Dark Dot	$\leq 3$	Joint Dot	$\leq 2$	Total	$\leq 3$	Minor
			Item	Acceptance (Q'ty)											
		Dot Defect	Bright Dot	$\leq 2$											
			Dark Dot	$\leq 3$											
			Joint Dot	$\leq 2$											
Total	$\leq 3$														
5. 1 Inspection pattern : full white , full black , Red , Green and blue screens.															
5. 2 It is defined as dot defect if defect area $> 1/2$ dot.															
5. 3 The distance between two dot defect $\geq 5$ mm.															

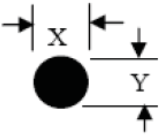
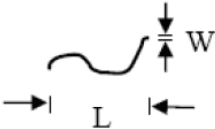

◆Specification For TFT-LCD Module Less Than 3.5" :

NO	Item	Criterion	Level																																								
06	<p>Black or white dot、scratch、contamination</p> <p>Round type</p>  <p><math>\Phi = (x + y) / 2</math></p> <p>Line type</p> 	<p>6.1 Round type ( Non-display or display ) :</p> <table border="1"> <thead> <tr> <th rowspan="2">Dimension (diameter : <math>\Phi</math>)</th> <th colspan="2">Acceptance (Q'ty)</th> </tr> <tr> <th>A area</th> <th>B area</th> </tr> </thead> <tbody> <tr> <td><math>\Phi \leq 0.15</math></td> <td colspan="2">Ignore</td> </tr> <tr> <td><math>0.15 &lt; \Phi \leq 0.20</math></td> <td>2</td> <td rowspan="3">Ignore</td> </tr> <tr> <td><math>0.20 &lt; \Phi \leq 0.30</math></td> <td>2</td> </tr> <tr> <td><math>\Phi &gt; 0.30</math></td> <td>0</td> </tr> <tr> <td><b>Total</b></td> <td colspan="2">3</td> </tr> </tbody> </table> <p>6.2 Line type( Non-display or display ) :</p> <table border="1"> <thead> <tr> <th colspan="2">Dimension</th> <th colspan="2">Acceptance (Q'ty)</th> </tr> <tr> <th>Length (L)</th> <th>Width (W)</th> <th>A area</th> <th>B area</th> </tr> </thead> <tbody> <tr> <td>---</td> <td><math>W \leq 0.03</math></td> <td>Ignore</td> <td rowspan="3">Ignore</td> </tr> <tr> <td><math>L \leq 5.0</math></td> <td><math>0.03 &lt; W \leq 0.05</math></td> <td>3</td> </tr> <tr> <td>---</td> <td><math>W &gt; 0.05</math></td> <td>As round type</td> </tr> <tr> <td colspan="2"><b>Total</b></td> <td colspan="2">3</td> </tr> </tbody> </table>	Dimension (diameter : $\Phi$ )	Acceptance (Q'ty)		A area	B area	$\Phi \leq 0.15$	Ignore		$0.15 < \Phi \leq 0.20$	2	Ignore	$0.20 < \Phi \leq 0.30$	2	$\Phi > 0.30$	0	<b>Total</b>	3		Dimension		Acceptance (Q'ty)		Length (L)	Width (W)	A area	B area	---	$W \leq 0.03$	Ignore	Ignore	$L \leq 5.0$	$0.03 < W \leq 0.05$	3	---	$W > 0.05$	As round type	<b>Total</b>		3		Minor
Dimension (diameter : $\Phi$ )	Acceptance (Q'ty)																																										
	A area	B area																																									
$\Phi \leq 0.15$	Ignore																																										
$0.15 < \Phi \leq 0.20$	2	Ignore																																									
$0.20 < \Phi \leq 0.30$	2																																										
$\Phi > 0.30$	0																																										
<b>Total</b>	3																																										
Dimension		Acceptance (Q'ty)																																									
Length (L)	Width (W)	A area	B area																																								
---	$W \leq 0.03$	Ignore	Ignore																																								
$L \leq 5.0$	$0.03 < W \leq 0.05$	3																																									
---	$W > 0.05$	As round type																																									
<b>Total</b>		3																																									
07	Polarizer Bubble	<table border="1"> <thead> <tr> <th rowspan="2">Dimension (diameter : <math>\Phi</math>)</th> <th colspan="2">Acceptance (Q'ty)</th> </tr> <tr> <th>A area</th> <th>B area</th> </tr> </thead> <tbody> <tr> <td><math>\Phi \leq 0.20</math></td> <td colspan="2">Ignore</td> </tr> <tr> <td><math>0.20 &lt; \Phi \leq 0.50</math></td> <td>3</td> <td rowspan="2">Ignore</td> </tr> <tr> <td><math>\Phi &gt; 0.50</math></td> <td>0</td> </tr> <tr> <td><b>Total</b></td> <td colspan="2">3</td> </tr> </tbody> </table>	Dimension (diameter : $\Phi$ )	Acceptance (Q'ty)		A area	B area	$\Phi \leq 0.20$	Ignore		$0.20 < \Phi \leq 0.50$	3	Ignore	$\Phi > 0.50$	0	<b>Total</b>	3		Minor																								
Dimension (diameter : $\Phi$ )	Acceptance (Q'ty)																																										
	A area	B area																																									
$\Phi \leq 0.20$	Ignore																																										
$0.20 < \Phi \leq 0.50$	3	Ignore																																									
$\Phi > 0.50$	0																																										
<b>Total</b>	3																																										

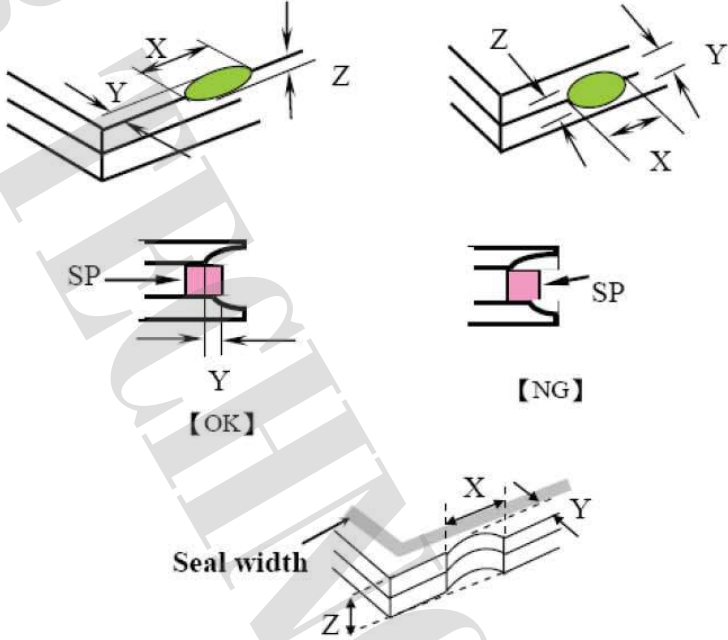

◆ Specification For TFT-LCD Module Less Than 3.5" :

NO	Item	Criterion	Level									
08	The crack of glass	<p>Symbols :</p> <p>X : The length of crack            Z : The thickness of crack            t : The thickness of glass</p> <p>Y : The width of crack.            W : terminal length            a : LCD side length</p> <hr/> <p>8.1 General glass chip :</p> <p>8.1.1 Chip on panel surface and crack between panels:</p>  <table border="1" data-bbox="557 1447 1334 1724"> <thead> <tr> <th>X</th> <th>Y</th> <th>Z</th> </tr> </thead> <tbody> <tr> <td><math>\leq a</math></td> <td>Crack can't enter viewing area</td> <td><math>\leq 1/2 t</math></td> </tr> <tr> <td><math>\leq a</math></td> <td>Crack can't exceed the half of SP width.</td> <td><math>1/2 t &lt; Z \leq 2 t</math></td> </tr> </tbody> </table>	X	Y	Z	$\leq a$	Crack can't enter viewing area	$\leq 1/2 t$	$\leq a$	Crack can't exceed the half of SP width.	$1/2 t < Z \leq 2 t$	Minor
X	Y	Z										
$\leq a$	Crack can't enter viewing area	$\leq 1/2 t$										
$\leq a$	Crack can't exceed the half of SP width.	$1/2 t < Z \leq 2 t$										



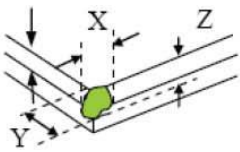
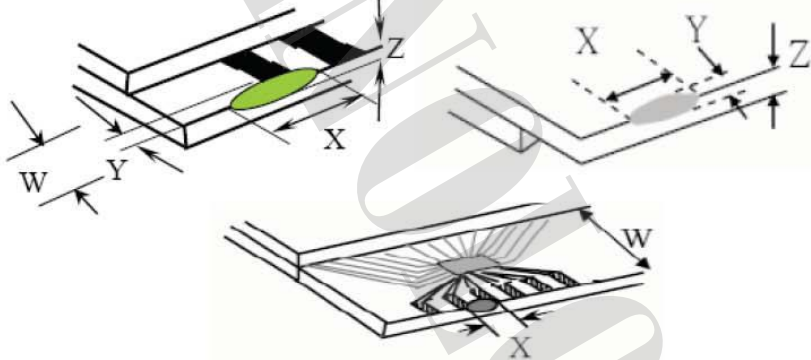

◆ Specification For TFT-LCD Module Less Than 3.5" :

NO	Item	Criterion	Level										
08	The crack of glass	<p>Symbols :</p> <p><b>X</b> : The length of crack  <b>Z</b> : The thickness of crack  <b>t</b> : The thickness of glass</p> <p><b>Y</b> : The width of crack.  <b>W</b> : terminal length  <b>a</b> : LCD side length</p> <hr/> <p>8.1.2 Corner crack :</p>  <table border="1" data-bbox="550 810 1332 1093"> <thead> <tr> <th>X</th> <th>Y</th> <th>Z</th> </tr> </thead> <tbody> <tr> <td><math>\leq 1/5 a</math></td> <td>Crack can't enter viewing area</td> <td><math>Z \leq 1/2 t</math></td> </tr> <tr> <td><math>\leq 1/5 a</math></td> <td>Crack can't exceed the half of SP width.</td> <td><math>1/2 t &lt; Z \leq 2 t</math></td> </tr> </tbody> </table>	X	Y	Z	$\leq 1/5 a$	Crack can't enter viewing area	$Z \leq 1/2 t$	$\leq 1/5 a$	Crack can't exceed the half of SP width.	$1/2 t < Z \leq 2 t$	Minor	
		X	Y	Z									
$\leq 1/5 a$	Crack can't enter viewing area	$Z \leq 1/2 t$											
$\leq 1/5 a$	Crack can't exceed the half of SP width.	$1/2 t < Z \leq 2 t$											
<p>8.2 Protrusion over terminal :</p> <p>8.2.1 Chip on electrode pad :</p>  <table border="1" data-bbox="582 1675 1340 1848"> <thead> <tr> <th></th> <th>X</th> <th>Y</th> <th>Z</th> </tr> </thead> <tbody> <tr> <td>Front</td> <td><math>\leq a</math></td> <td><math>\leq 1/2 W</math></td> <td><math>\leq t</math></td> </tr> <tr> <td>Back</td> <td><math>\leq a</math></td> <td><math>\leq W</math></td> <td><math>\leq 1/2 t</math></td> </tr> </tbody> </table>		X	Y	Z	Front	$\leq a$	$\leq 1/2 W$	$\leq t$	Back	$\leq a$	$\leq W$	$\leq 1/2 t$	
	X	Y	Z										
Front	$\leq a$	$\leq 1/2 W$	$\leq t$										
Back	$\leq a$	$\leq W$	$\leq 1/2 t$										





◆Specification For TFT-LCD Module Less Than 3.5" :

NO	Item	Criterion	Level
09	Backlight elements	9.1 Backlight can't work normally.	Major
		9.2 Backlight doesn't light or color is wrong.	Major
		9.3 Illumination source flickers when lit.	Major
10	General appearance	10.1 Pin type 、 quantity 、 dimension must match type in structure diagram.	Major
		10.2 No short circuits in components on PCB or FPC .	Major
		10.3 Parts on PCB or FPC must be the same as on the production characteristic chart .There should be no wrong parts , missing parts or excess parts.	Major
		10.4 Product packaging must the same as specified on packaging specification sheet.	Minor
		10.5 The folding and peeled off in polarizer are not acceptable.	Minor
		10.6 The PCB or FPC between B/L assembled distance(PCB or FPC ) is $\leq 1.5$ mm.	Minor





## 5. PRECAUTION RELATING PRODUCT HANDLING

### 5.1 SAFETY

5.1.1 If the LCD panel breaks , be careful not to get the liquid crystal to touch your skin.

5.1.2 If the liquid crystal touches your skin or clothes , please wash it off immediately by using soap and water.

### 5.2 HANDLING

5.2.1 Avoid any strong mechanical shock which can break the glass.

5.2.2 Avoid static electricity which can damage the CMOS LSI—When working with the module , be sure to ground your body and any electrical equipment you may be using.

5.2.3 Do not remove the panel or frame from the module.

5.2.4 The polarizing plate of the display is very fragile. So , please handle it very carefully, do not touch , push or rub the exposed polarizing with anything harder than an HB pencil lead (glass , tweezers , etc.)

5.2.5 Do not wipe the polarizing plate with a dry cloth , as it may easily scratch the surface of plate.

5.2.6 Do not touch the display area with bare hands , this will stain the display area.

5.2.7 Do not use ketonics solvent & aromatic solvent. Use with a soft cloth soaked with a cleaning naphtha solvent.

5.2.8 To control temperature and time of soldering is  $320 \pm 5^{\circ}\text{C}$  and 3-5 sec.

5.2.9 To avoid liquid (include organic solvent) stained on LCM

### 5.3 STORAGE

5.3.1 Store the panel or module in a dark place where the temperature is  $25^{\circ}\text{C} \pm 5^{\circ}\text{C}$  and the humidity is below 65% RH.

5.3.2 Do not place the module near organics solvents or corrosive gases.

5.3.3 Do not crush , shake , or jolt the module.

### 5.4 TERMS OF WARRANTY

5.4.1 Applicable warrant period

The period is within one year since the date of shipping out under normal using and storage conditions.

5.4.2 Unaccepted responsibility

This product has been manufactured to your company's specification as a part for use in your company's general electronic products. It is guaranteed to perform according to delivery specifications. For any other use apart from general electronic equipment, we cannot take responsibility if the product is used in nuclear power control equipment, aerospace equipment , fire and security systems or any other applications in which there is a direct risk to human life and where extremely high levels of reliability are required.



## 6. Appendix

### 6.1 LCM Drawing

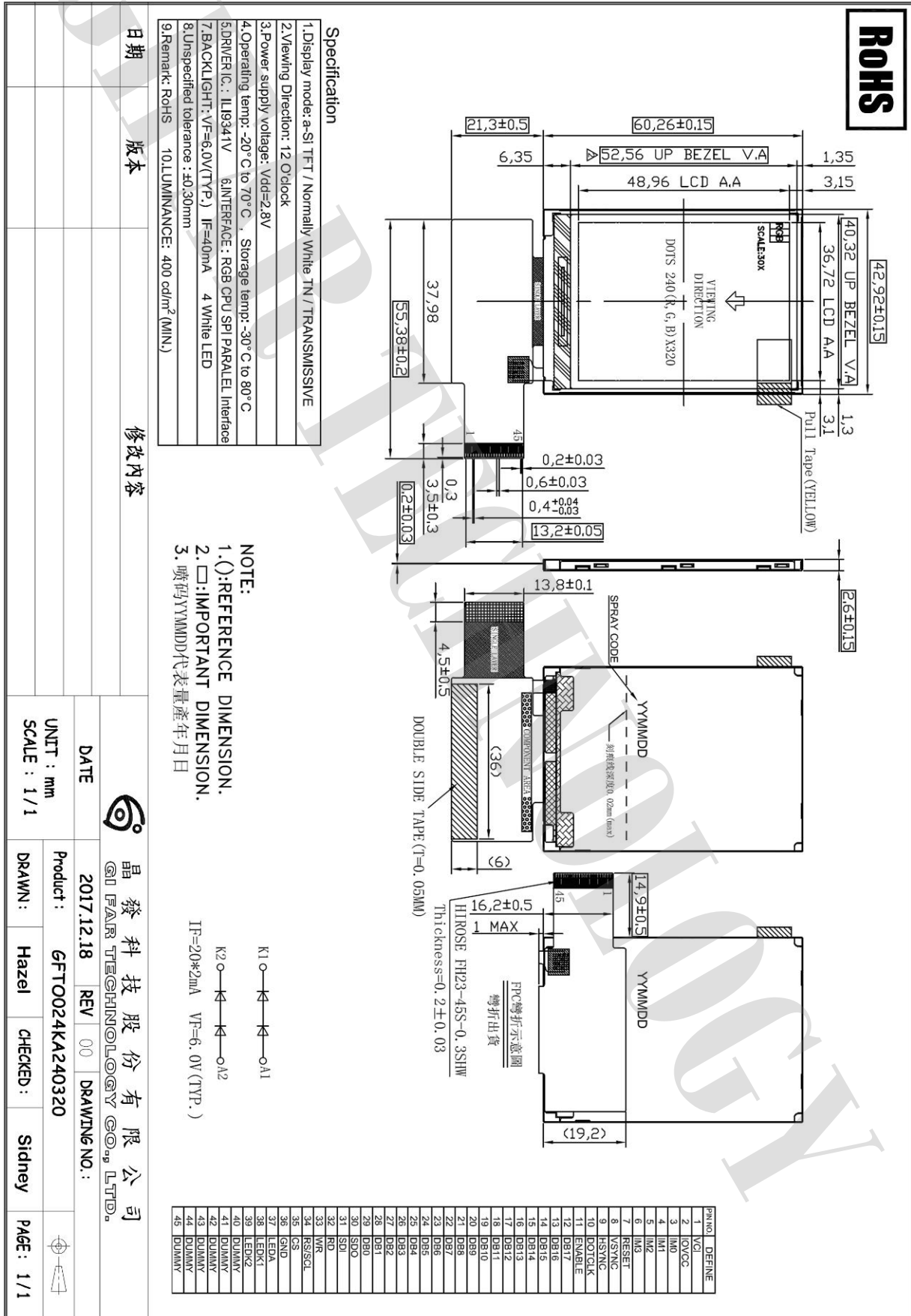



## 6.2 Package Drawing

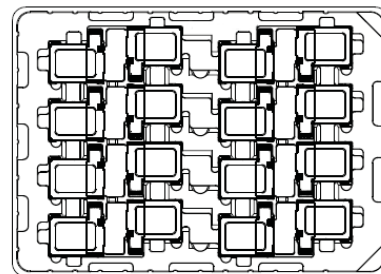
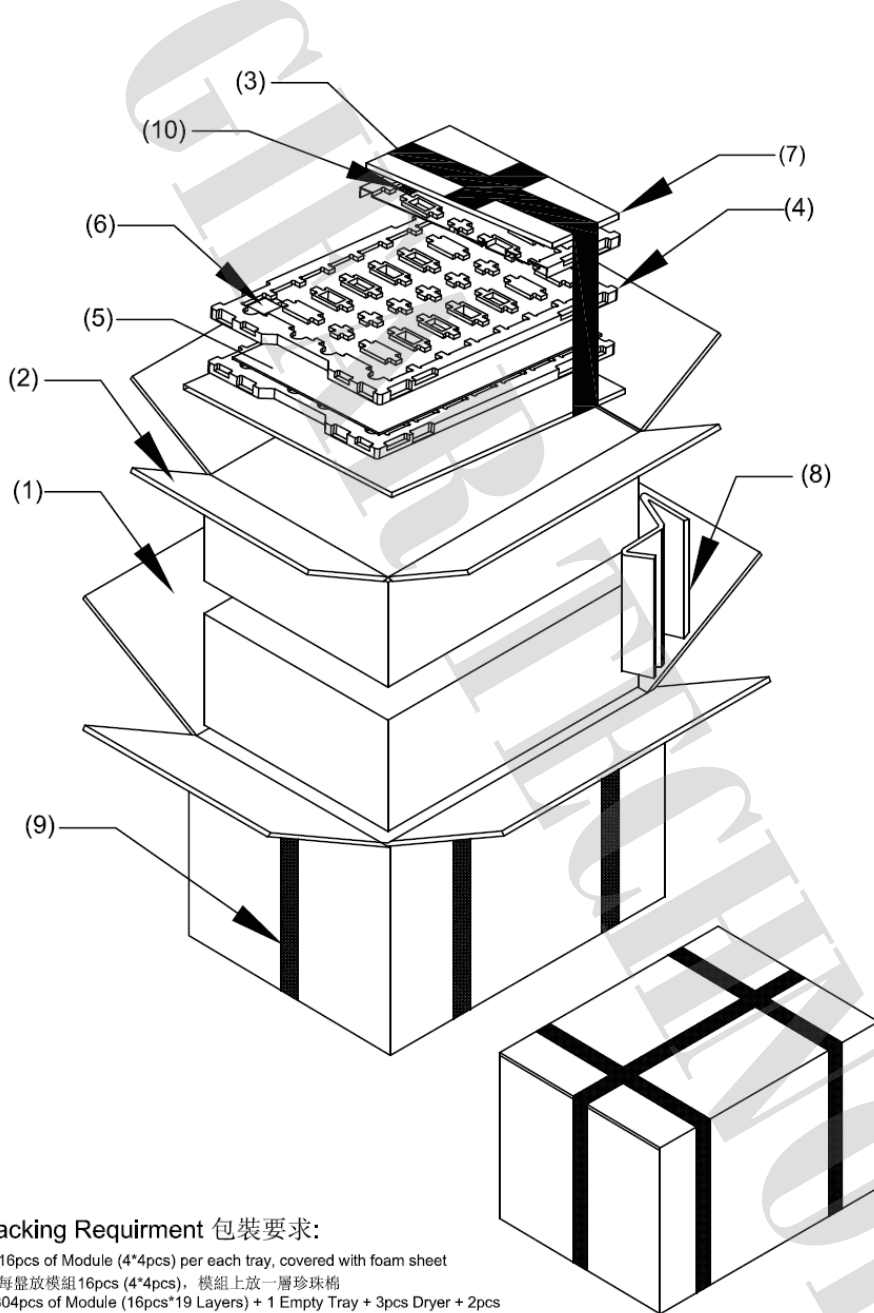

Tray+ LCM Module

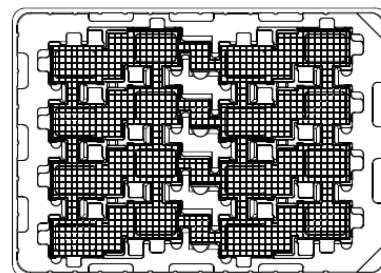

Tray+ LCM Module+Foam Sheet



Stack Drawing

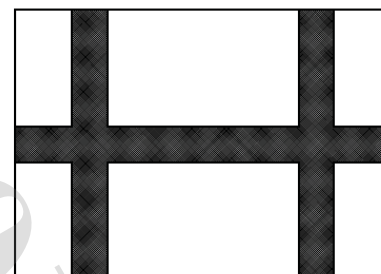

Tray+ LCM Module+Foam Sheet+Paper Board

### Packing Requirement 包裝要求:

- 16pcs of Module (4\*4pcs) per each tray, covered with foam sheet  
每盤放模組 16pcs (4\*4pcs), 模組上放一層珍珠棉
- 304pcs of Module (16pcs\*19 Layers) + 1 Empty Tray + 3pcs Dryer + 2pcs Paper Board + 1pcs PE bag vacuumize on top per Inner Box, sealed with adhesive tape, add product label  
每內箱放模組 304pcs (16pcs\*19層) + 頂部放一空盤 + 3包乾燥劑+2塊紙板+1個PE袋真空包裝, 膠紙封箱, 貼產品標籤
- Each layer of tray must be stacked in 180° cross position  
每層吸塑盤之間必須 180° 交錯堆疊
- 608pcs (2 Inner Boxes) per Outer Carton, sealed with adhesive tape and PP strip, add product label  
每外箱放產品 608pcs (2內箱), 膠紙封箱, 打PP帶, 貼標籤
- Each Inner Box 3pcs Dryer on top Empty Tray;  
每個內箱頂部的空吸塑盤上放3包乾燥劑:

#### IMPORTANT 重要:

- Each layer of tray must be stacked in 180° cross position;  
每層吸塑盤之間必須 180° 交錯堆疊
- Each layer on both sides of the product must be placed relatively;  
每層吸塑盤兩側產品必須相對放置

	NAME	UNIT	QTY PER	SPEC	MATERIAL	REMARK
1	Outer Carton	PCS	1	466*346*316	PAPER	"A"TPY
2	Inner Box	PCS	2	435*315*143	PAPER	"B"TPY
3	Adhesive Tape	m	6	1	PE	++ SHAPE
4	PET Tray	PCS	40	420*300*12.5	PET	ESD 10 <sup>6</sup> -10 <sup>11</sup>
5	Foam Sheet	PCS	38	334.38*233.82*1.0	EPE	ESD 10 <sup>6</sup> -10 <sup>11</sup>
6	Module	PCS	608	42.92*60.26*2.6		BE CAREFUL IN PUT
7	Paper Board	PCS	4	425*305*6.0	PAPER	"B"TPY
8	Paper Board	PCS	4	288*285*6.0	PAPER	"B"TPY
9	Packing Strip	m	6	4.5	PP	
10	PE BAG	PCS	2			
11	Dryer	PCS	6			