

REVISONS		DATE	BY	APPV
D	REV PER ECO-07-017102	20SEP07	PY	BW

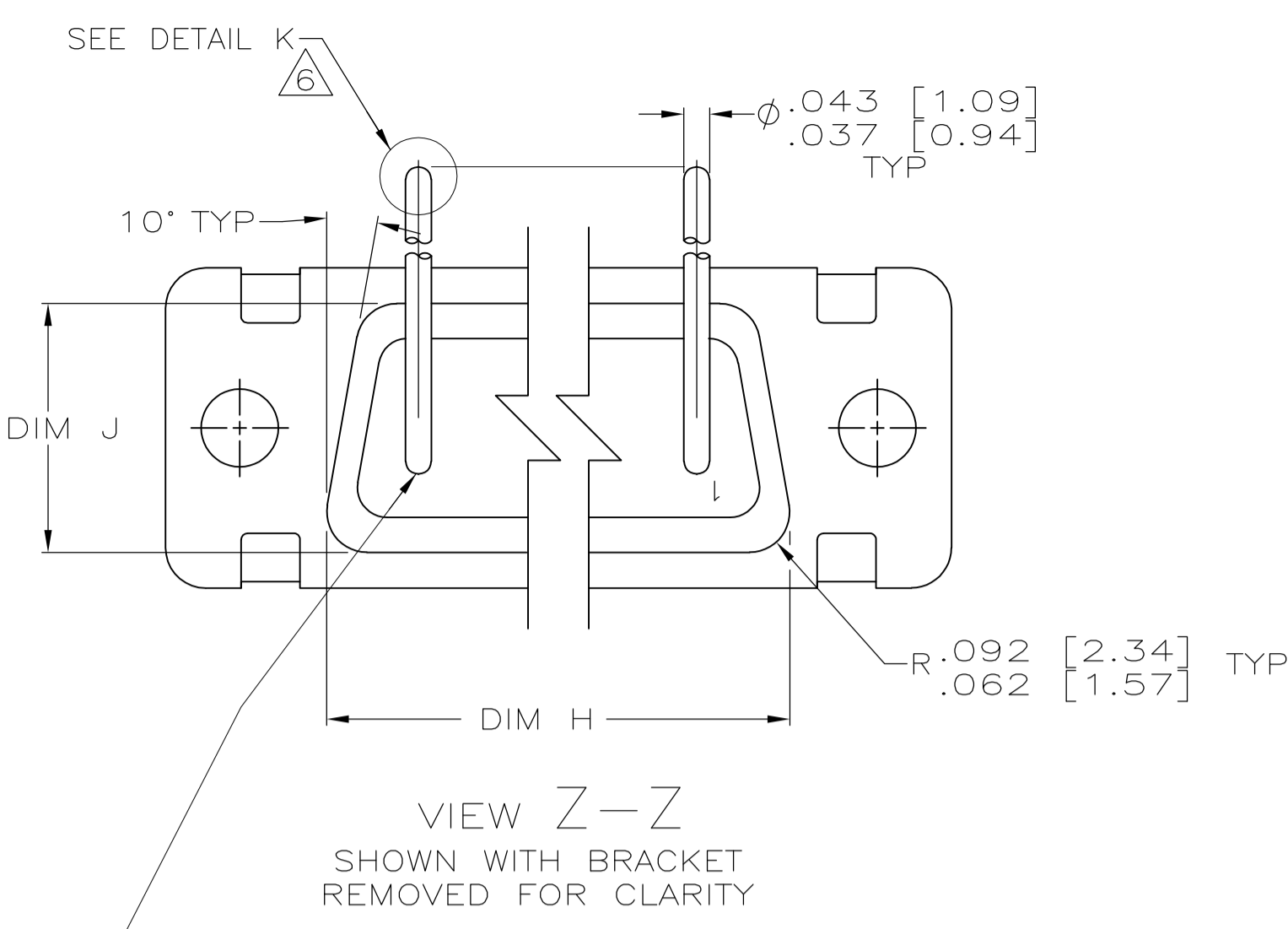

CONTACT (QTY = NO. OF POSN)
 MATL: BRASS PER ASTM-B-16, OR BERYLLIUM COPPER PER ASTM-B-194
 FINISH: GOLD PER MIL-G-45204, TYPE II, GRADE C, CLASS 1 IN CONTACT MATING AREA, .000010 [0.0003] MIN THK GOLD PER MIL-G-45204 OVER .000050 [0.0013] MIN THK NICKEL PER QQ-N-290 ON CONTACT BODY

- 1. SEE SHEET 2 FOR RECOMMENDED P.C. BOARD LAYOUT. TRUE POSITION TOLERANCE FOR P.C. BOARD LAYOUT IS .010 [0.25] AT MAX MATERIAL CONDITION. SUGGESTED BOARD THICKNESS IS .125 [3.18]
- 2. THE CONNECTORS DESCRIBED IN THIS DOCUMENT MEET THE REQUIREMENTS OF MIL-C-24308 AND MATE WITH ANY PLUG CONNECTOR WITH SAME INSERT ARRANGEMENT.
- 3. MARKED WITH .047 [1.19]-.062 [1.57] HIGH CHARACTERS. FAR SIDE REFERS TO THE WIDE SIDE OF THE KEYSTONE. NEAR SIDE REFERS TO THE NARROW SIDE OF THE KEYSTONE. IF THE REAR SHELL IS TOO SMALL FOR THE ENTIRE MILITARY PART NUMBER, MARKING SHALL BE LOCATED AS FOLLOWS:
 - A. "M24308" ON FRONT SHELL, FAR SIDE.
 - B. SLASH SHEET AND DASH NUMBER ON REAR SHELL, FAR SIDE.
 - C. "AMP" AND DATE CODE ON FRONT SHELL, NEAR SIDE.
 - D. AMP PART NUMBER ON REAR SHELL, NEAR SIDE.
- IF THE FRONT SHELL IS TOO SMALL FOR "AMP", AMP PART NUMBER AND DATE CODE, MARKING SHALL BE SPLIT AS FOLLOWS:
 - A. AMP PART NUMBER ON REAR SHELL, NEAR SIDE.
 - B. "AMP" AND DATE CODE ON FRONT SHELL, NEAR SIDE.
 - C. MILITARY PART NUMBER ON REAR SHELL, FAR SIDE.
- 4. POINT OF ELECTRICAL ENGAGEMENT - AS MEASURED WITH A .0390 [0.991]-.0393 [0.998] DIA SQUARE ENDED TEST PIN.
- 5. THIS DRAWING SHALL BE INTERPRETED IN ACCORDANCE WITH APPLICABLE STANDARDS LISTED IN MIL-STD-100.
- 6. SOLDER DIP PER MIL-STD-2000 COMPOSITION Sn63 CONFORMING TO QQ-S-571 IN THE ENTIRE AREA OF DIMENSION SHOWN. 1218435-6 THRU -10 ONLY.

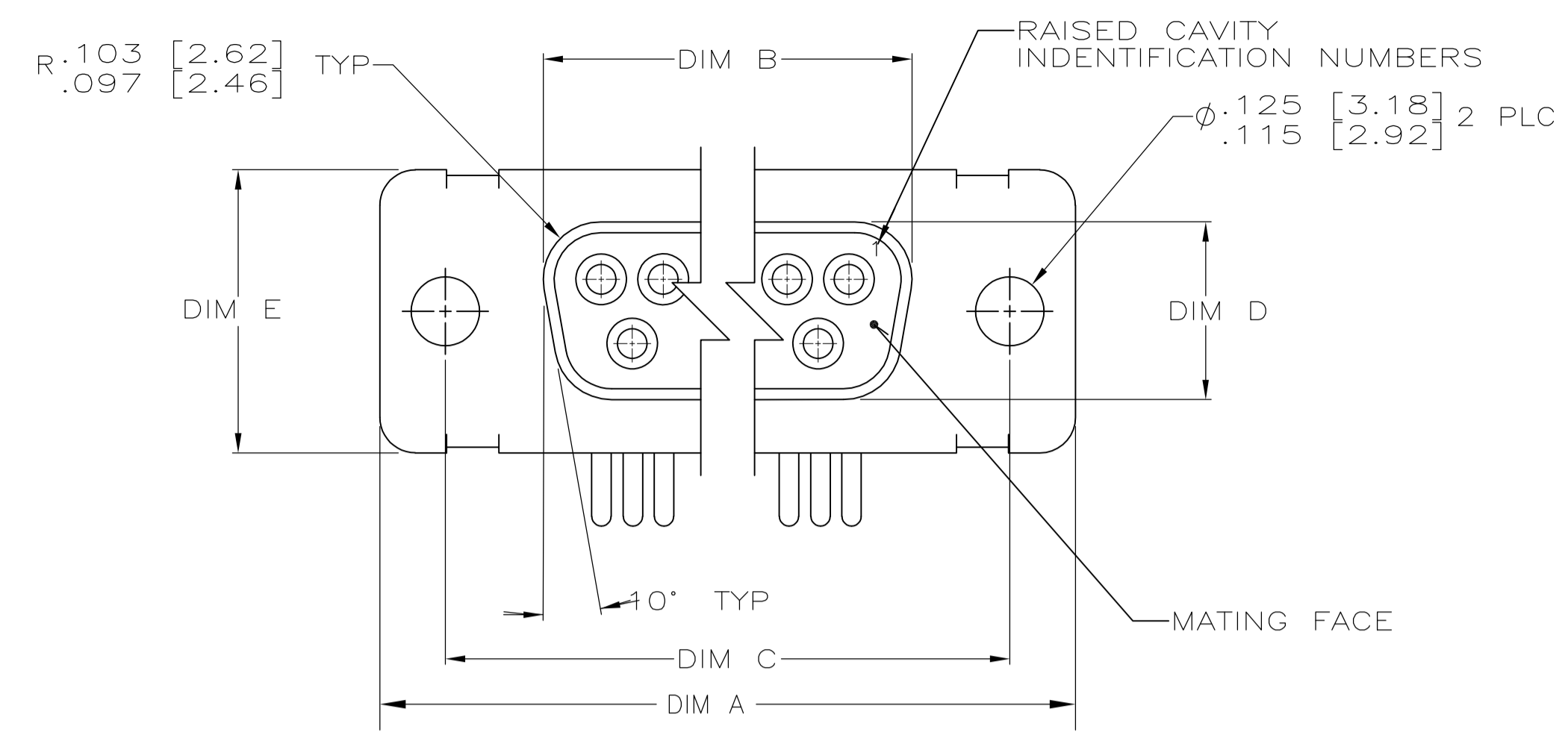
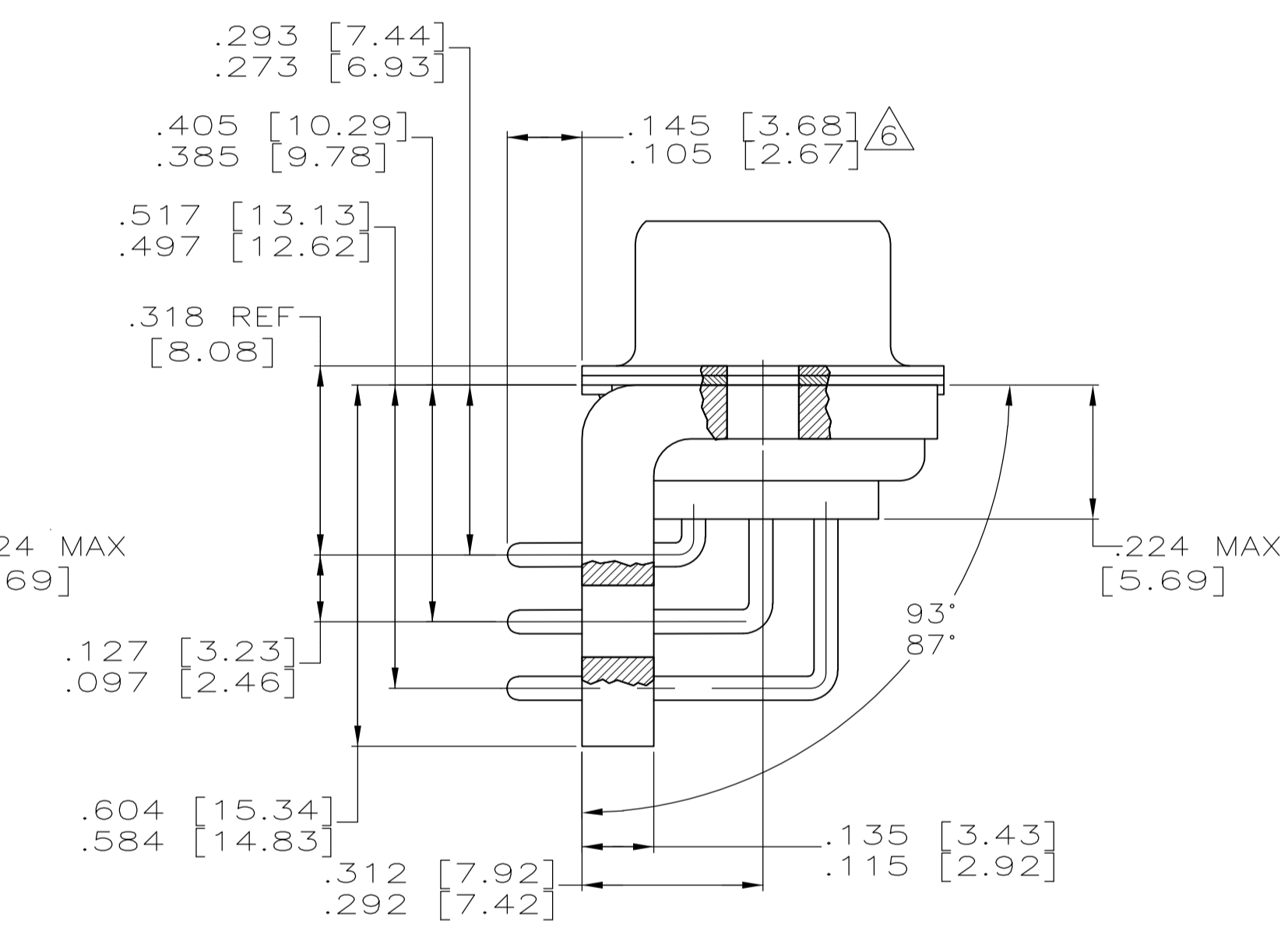
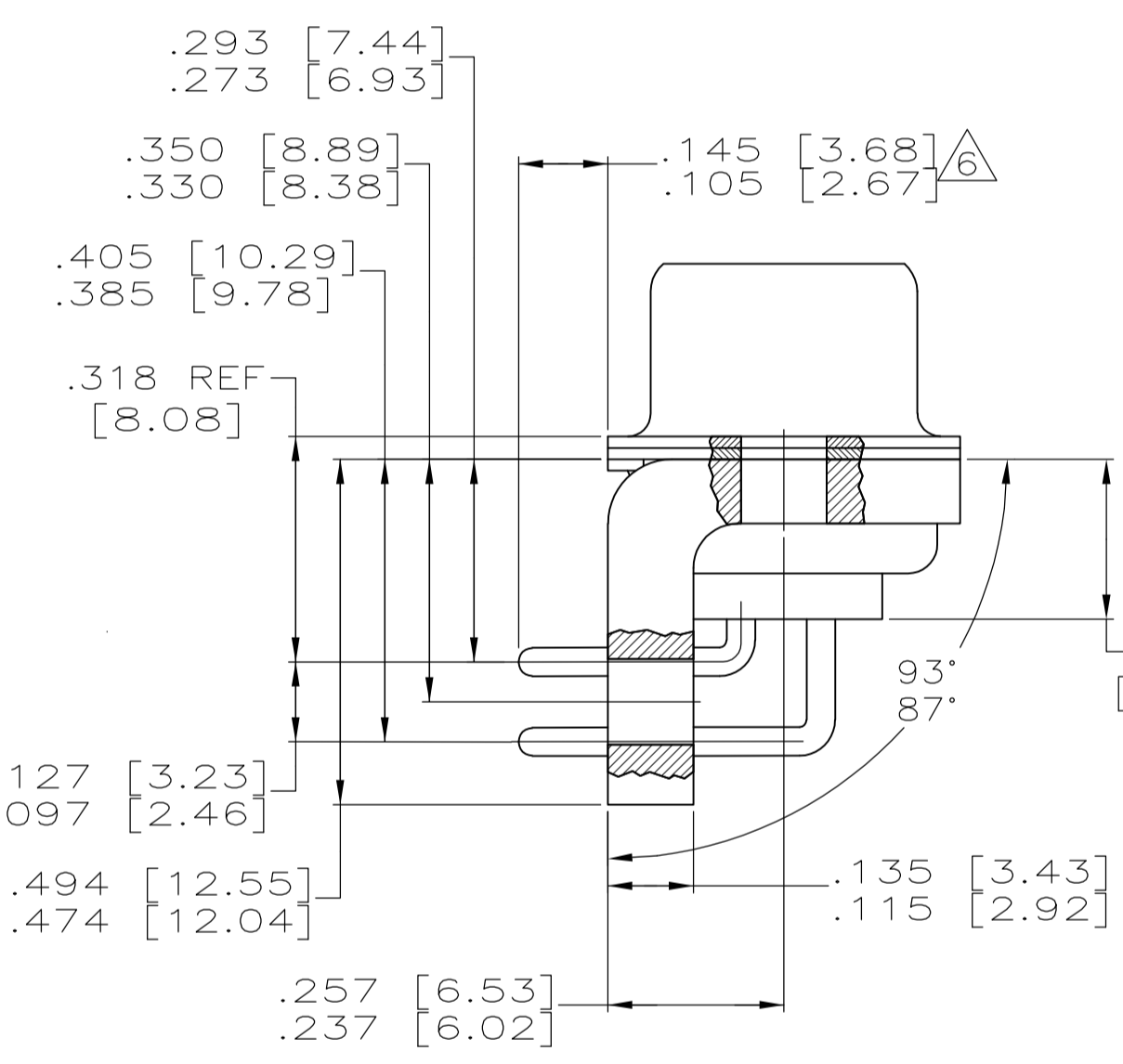
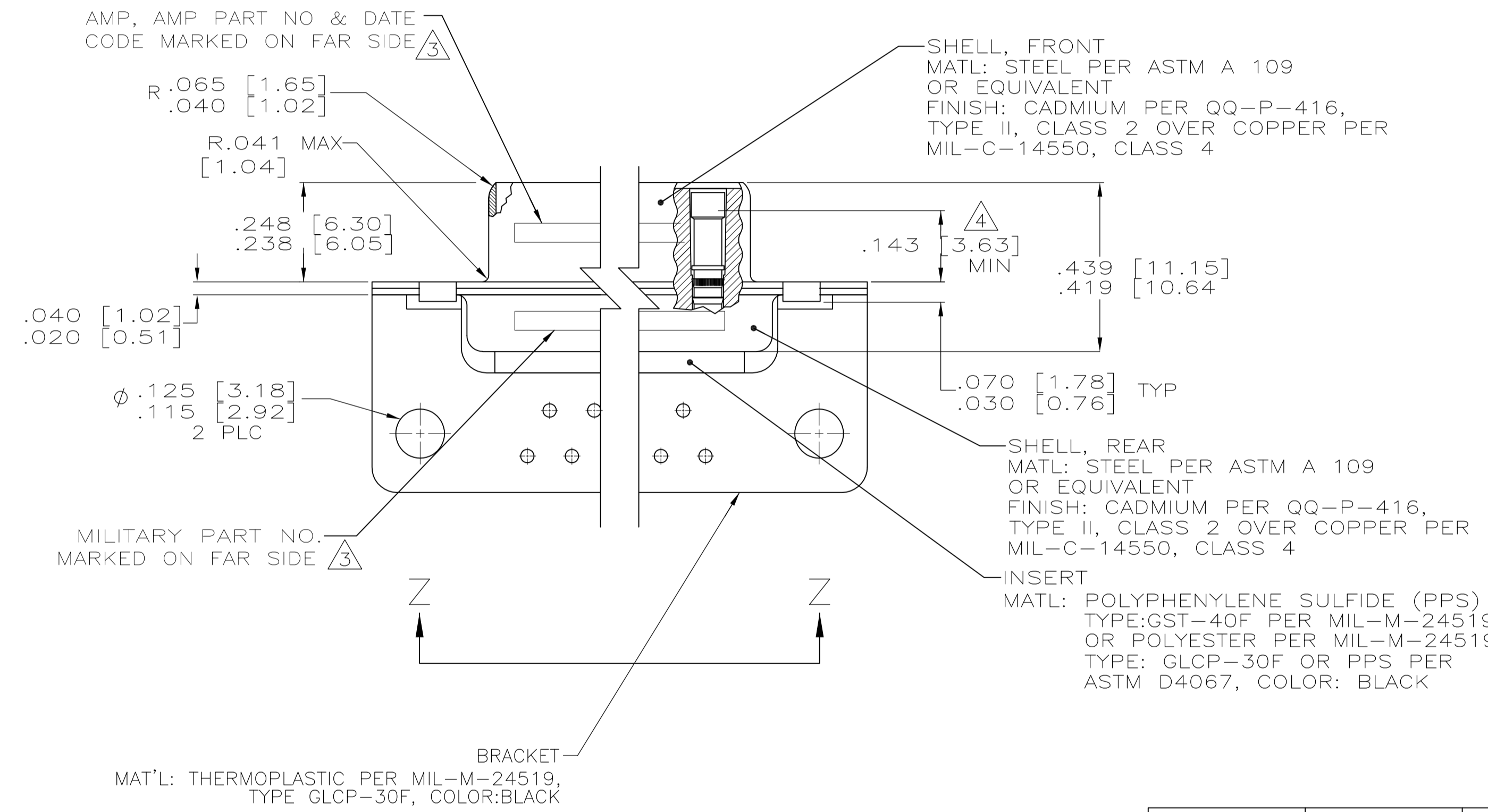

SHELL SIZES 1 THRU 4 CONTACT CONFIGURATION

SHELL SIZE 5 CONTACT CONFIGURATION

.544 [13.82]	2.188 [55.58]	.620 [15.75]	.428 [10.87]	2.411 [61.24]	2.069 [52.55]	2.650 [67.31]
.524 [13.31]	2.168 [55.07]	.590 [14.99]	.418 [10.62]	2.401 [60.99]	2.059 [52.30]	2.620 [66.55]
.432 [10.97]	2.282 [57.96]	.509 [12.93]	.316 [8.03]	2.505 [63.63]	2.164 [54.97]	2.744 [69.70]
.412 [10.46]	2.262 [57.45]	.479 [12.17]	.306 [7.77]	2.495 [63.37]	2.154 [54.71]	2.714 [68.94]
.432 [10.97]	1.635 [41.53]	.509 [12.93]	.316 [8.03]	1.857 [47.17]	1.516 [38.51]	2.103 [53.42]
.412 [10.46]	1.615 [41.02]	.479 [12.17]	.306 [7.77]	1.847 [46.91]	1.506 [38.25]	2.073 [52.65]
.432 [10.97]	1.093 [27.76]	.509 [12.93]	.316 [8.03]	1.317 [33.45]	.976 [24.79]	1.556 [39.52]
.412 [10.46]	1.073 [27.25]	.479 [12.17]	.306 [7.77]	1.307 [33.20]	.966 [24.54]	1.526 [38.76]
.432 [10.97]	.769 [19.53]	.509 [12.93]	.316 [8.03]	.989 [25.12]	.648 [16.46]	1.228 [31.19]
.412 [10.46]	.749 [19.02]	.479 [12.17]	.306 [7.77]	.979 [24.87]	.638 [16.21]	1.198 [30.43]
.544 [13.82]	2.188 [55.58]	.620 [15.75]	.428 [10.87]	2.411 [61.24]	2.069 [52.55]	2.650 [67.31]
.524 [13.31]	2.168 [55.07]	.590 [14.99]	.418 [10.62]	2.401 [60.99]	2.059 [52.30]	2.620 [66.55]
.432 [10.97]	2.282 [57.96]	.509 [12.93]	.316 [8.03]	2.505 [63.63]	2.164 [54.97]	2.744 [69.70]
.412 [10.46]	2.262 [57.45]	.479 [12.17]	.306 [7.77]	2.495 [63.37]	2.154 [54.71]	2.714 [68.94]
.432 [10.97]	1.635 [41.53]	.509 [12.93]	.316 [8.03]	1.857 [47.17]	1.516 [38.51]	2.103 [53.42]
.412 [10.46]	1.615 [41.02]	.479 [12.17]	.306 [7.77]	1.847 [46.91]	1.506 [38.25]	2.073 [52.65]
.432 [10.97]	1.093 [27.76]	.509 [12.93]	.316 [8.03]	1.317 [33.45]	.976 [24.79]	1.556 [39.52]
.412 [10.46]	1.073 [27.25]	.479 [12.17]	.306 [7.77]	1.307 [33.20]	.966 [24.54]	1.526 [38.76]
.432 [10.97]	.769 [19.53]	.509 [12.93]	.316 [8.03]	.989 [25.12]	.648 [16.46]	1.228 [31.19]
.412 [10.46]	.749 [19.02]	.479 [12.17]	.306 [7.77]	.979 [24.87]	.638 [16.21]	1.198 [30.43]

DIM J	DIM H	DIM E	DIM D	DIM C	DIM B	DIM A	INSERT ARRANGEMENT	NO OF POS	SHELL SIZE	MILITARY P/N ON CONNECTOR	AMP P/N MARKED ON CONNECTOR	AMP PART NO.
.544 [13.82]	2.188 [55.58]	.620 [15.75]	.428 [10.87]	2.411 [61.24]	2.069 [52.55]	2.650 [67.31]	MS18277-1	50	5	M24308/23-41F	1218435-5	1-1218435-0
.432 [10.97]	2.282 [57.96]	.509 [12.93]	.316 [8.03]	2.505 [63.63]	2.164 [54.97]	2.744 [69.70]	MS18276-1	37	4	M24308/23-40F	1218435-4	1218435-9
.432 [10.97]	1.635 [41.53]	.509 [12.93]	.316 [8.03]	1.857 [47.17]	1.516 [38.51]	2.103 [53.42]	MS18275-1	25	3	M24308/23-39F	1218435-3	1218435-8
.432 [10.97]	1.093 [27.76]	.509 [12.93]	.316 [8.03]	1.317 [33.45]	.976 [24.79]	1.556 [39.52]	MS18274-1	15	2	M24308/23-38F	1218435-2	1218435-7
.432 [10.97]	.769 [19.53]	.509 [12.93]	.316 [8.03]	.989 [25.12]	.648 [16.46]	1.228 [31.19]	MS18273-1	9	1	M24308/23-37F	1218435-1	1218435-6
.544 [13.82]	2.188 [55.58]	.620 [15.75]	.428 [10.87]	2.411 [61.24]	2.069 [52.55]	2.650 [67.31]	MS18277-1	50	5	M24308/23-41F	1218435-5	1218435-5
.432 [10.97]	2.282 [57.96]	.509 [12.93]	.316 [8.03]	2.505 [63.63]	2.164 [54.97]	2.744 [69.70]	MS18276-1	37	4	M24308/23-40F	1218435-4	1218435-4
.432 [10.97]	1.635 [41.53]	.509 [12.93]	.316 [8.03]	1.857 [47.17]	1.516 [38.51]	2.103 [53.42]	MS18275-1	25	3	M24308/23-39F	1218435-3	1218435-3
.432 [10.97]	1.093 [27.76]	.509 [12.93]	.316 [8.03]	1.317 [33.45]	.976 [24.79]	1.556 [39.52]	MS18274-1	15	2	M24308/23-38F	1218435-2	1218435-2
.432 [10.97]	.769 [19.53]	.509 [12.93]	.316 [8.03]	.989 [25.12]	.648 [16.46]	1.228 [31.19]	MS18273-1	9	1	M24308/23-37F	1218435-1	1218435-1

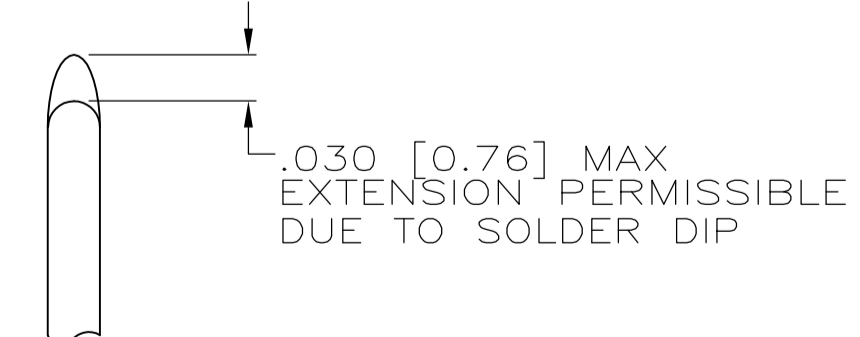

DETAIL K SCALE 8:1 FOR 1218435-6 THRU -10 ONLY

THIS DRAWING IS A CONTROLLED DOCUMENT.

DIMENSIONS: INCHES
 TOLERANCES UNLESS OTHERWISE SPECIFIED:
 0 PLC ± .005
 1 PLC ± .005
 2 PLC ± .005
 3 PLC ± .010 [0.25]
 4 PLC ± .010 [0.25]
 ANGLES ± 1°

MATERIAL: SEE CALLOUTS
 FINISH: SEE CALLOUTS

WEIGHT: —
 CUSTOMER DRAWING

DWG: C.C. THOMAS 12-3-99
 CHK: CHAD BAKER 12-15-99
 APPV: CHAD BAKER 12-15-99

Tyco Electronics Corporation
 Harrisburg, PA 17105-3608

NAME: RECEPTACLE ASSY, AMPLIMITE RIGHT ANGLE, SERIES 109 SIZES 1 THRU 5

SIZE: A1
 CASE CODE: 00779
 DRAWING NO: 1218435

RESTRICTED TO: —
 SCALE: 4:1
 SHEET: 1 OF 2
 REV: D

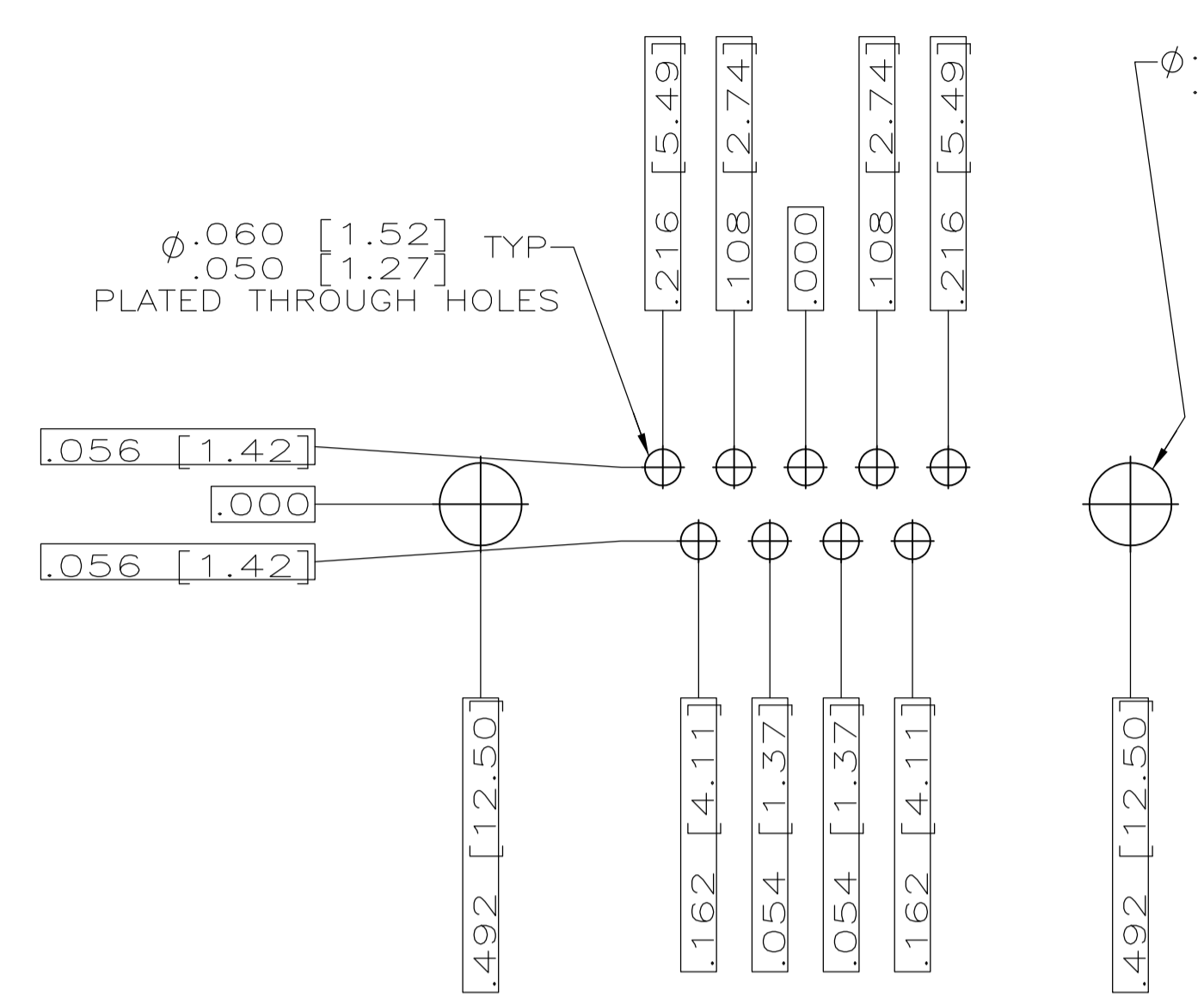

RECOMMENDED P.C. BOARD LAYOUT
SHELL SIZE 1 (9 POSITION)

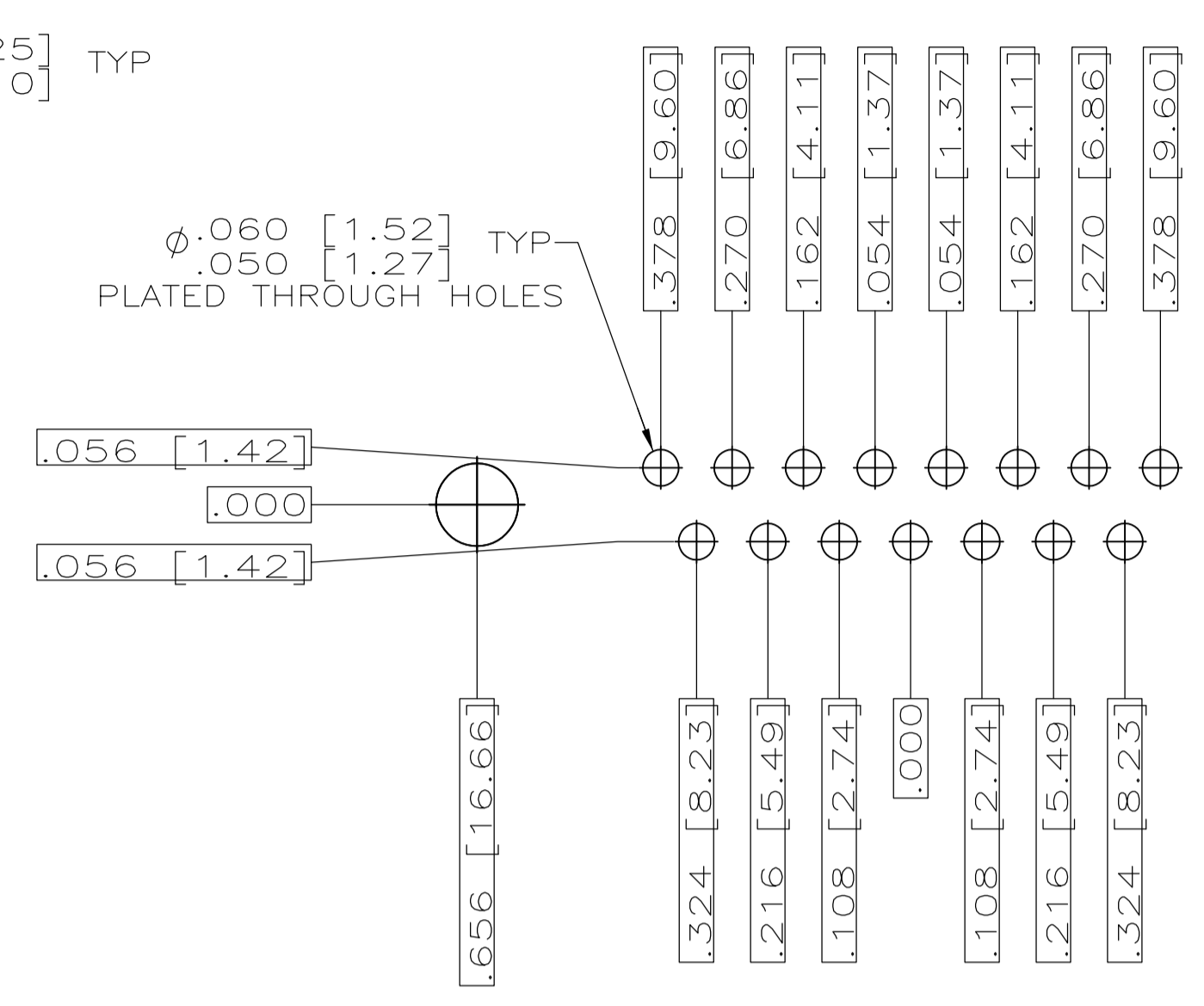

RECOMMENDED P.C. BOARD LAYOUT
SHELL SIZE 2 (15 POSITION)

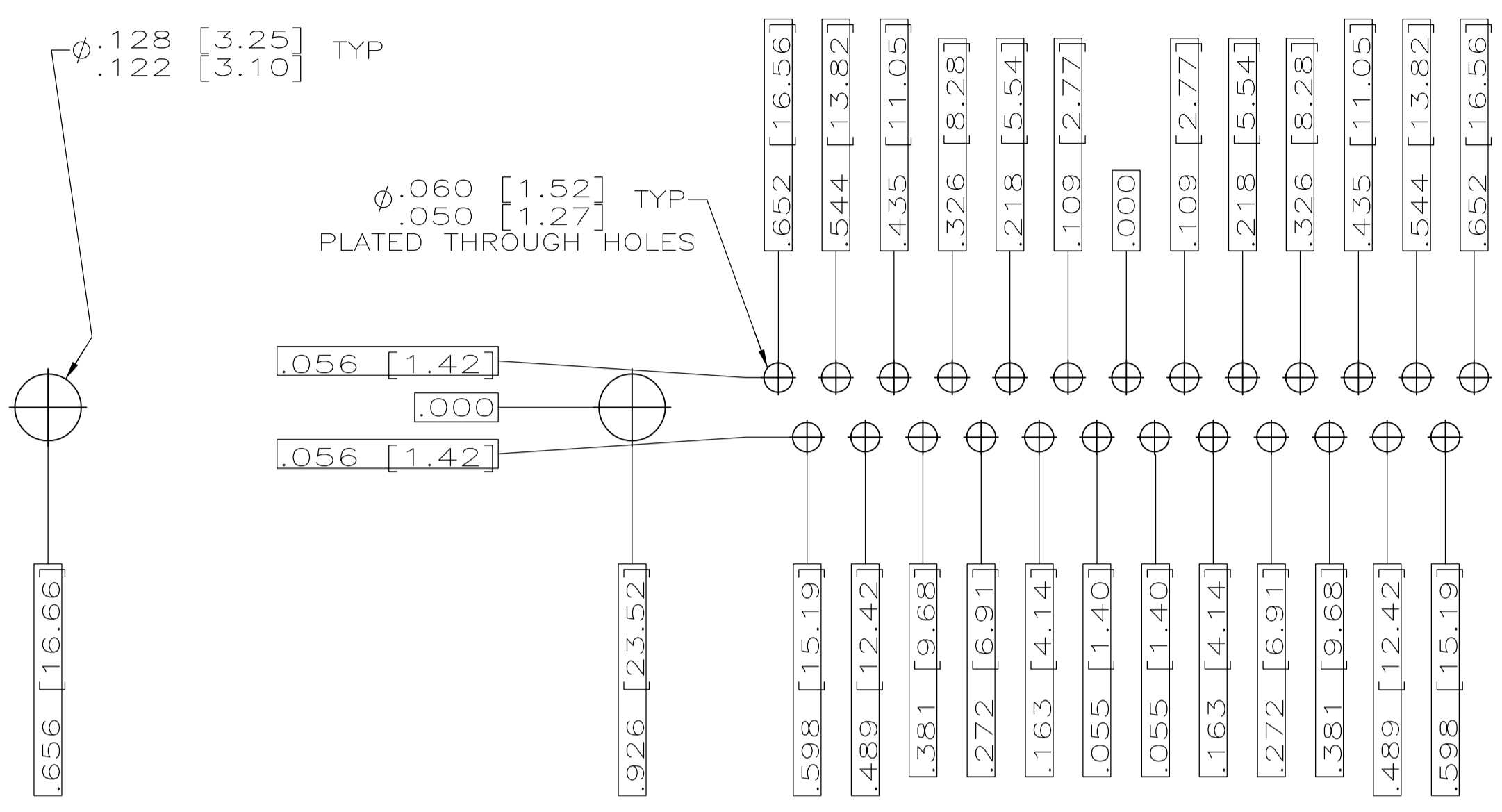

RECOMMENDED P.C. BOARD LAYOUT
SHELL SIZE 3 (25 POSITION)

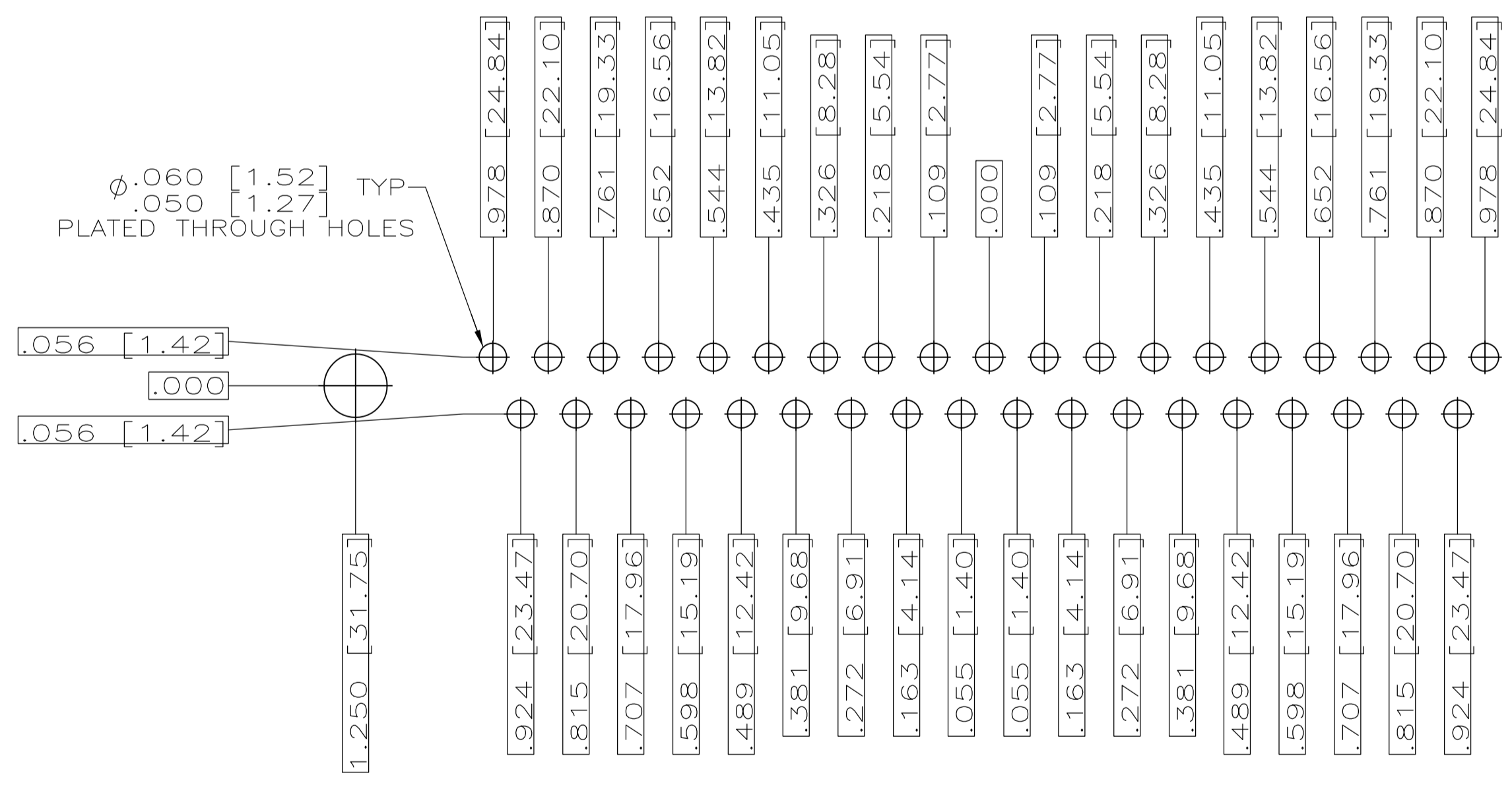

RECOMMENDED P.C. BOARD LAYOUT
SHELL SIZE 4 (37 POSITION)

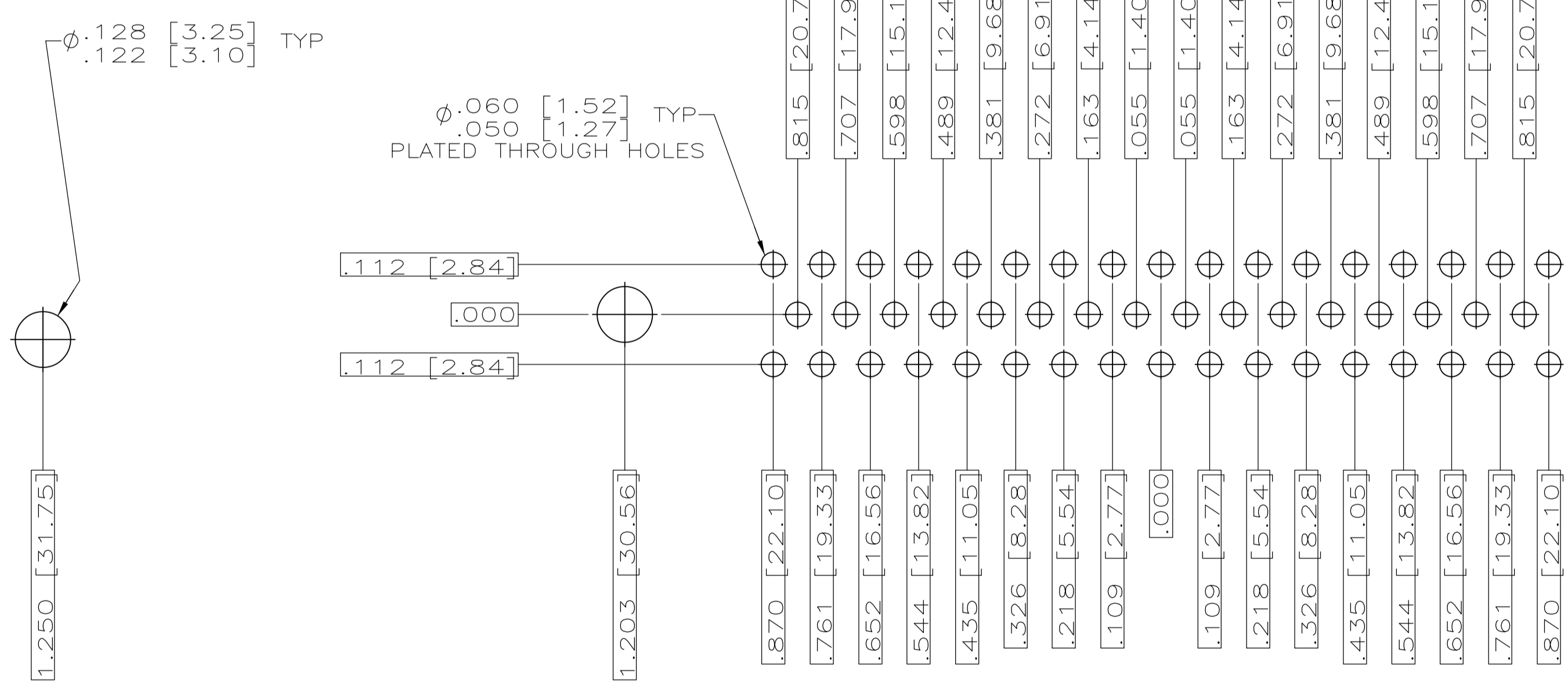

RECOMMENDED P.C. BOARD LAYOUT
SHELL SIZE 5 (50 POSITION)

THIS DRAWING IS A CONTROLLED DOCUMENT.		DN C.C.THOMAS 12-6-99	Tyco Electronics Corporation Harrisburg, PA 17105-3608	
DIMENSIONS: INCHES		CHK CHAD BAKER 12-15-99	NAME RECEPTACLE ASSY,AMPLITE RIGHT ANGLE,SERIES 109,SIZE 1 THRU 5	
TOLERANCES UNLESS OTHERWISE SPECIFIED: 0 PLC ± .005 1 PLC ± .005 2 PLC ± .005 3 PLC ± .010 (0.25) 4 PLC ± .010 (0.25) ANGLES ± .4°		APVD CHAD BAKER 12-15-99	RESTRICTED TO	
MATERIAL SEE CALLOUTS		FINISH SEE CALLOUTS	WEIGHT -	SIZE A1
CUSTOMER DRAWING		SCALE 4:1	SHEET 2 OF 2	REV D