

THESE DRAWINGS ARE THE PROPERTY OF QUALTEK ELECTRONICS AND NOT TO BE REPRODUCED FOR OR COMMUNICATED TO A THIRD PARTY WITHOUT THE EXPRESS WRITTEN PERMISSION OF AN OFFICER OF QUALTEK ELECTRONICS.

REVISION			
REV.	DESCRIPTION	DATE	APPROVED

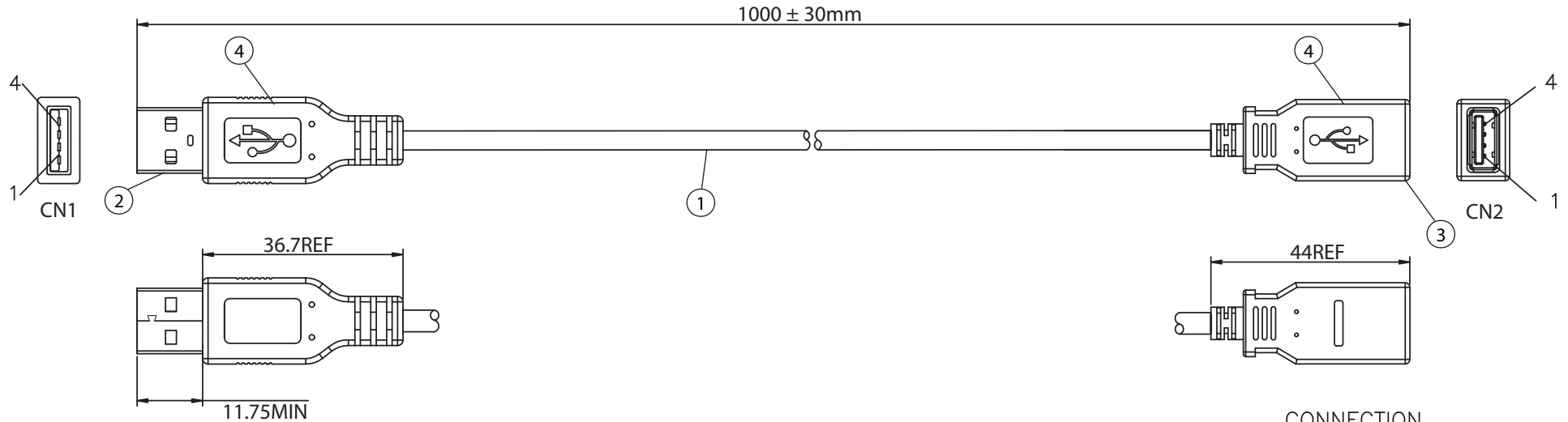

CONNECTION

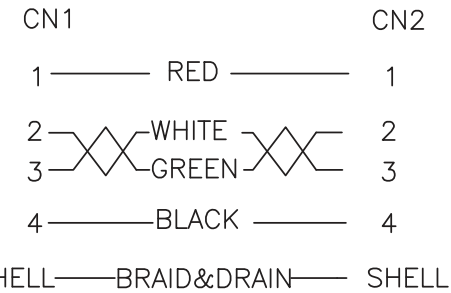

NOTES:

1. CABLE: UL2725  
28AWGx1PR+24AWGx2C+ AEB(AL) 65%  
OUTER JACKET: BLACK, OD: 4.5 ± 0.2mm
2. CONNECTOR: USB 2.0 A TYPE MALE  
INSULATOR: WHITE PBT  
PIN G/F  
NICKEL PLATED SHELL
3. CONNECTOR: USB 2.0 A TYPE FEMALE  
INSULATOR: WHITE PBT  
PIN G/F  
NICKEL PLATED SHELL
4. PVC MOLDED: COLOR 45P BLACK
5. ELECTRICAL TEST:  
  - <1>.100% OPEN SHORT & MISS WIRE TEST
  - <2>.INSULATION RESISTANCE: DC300V 10M ohm MIN.
  - <3>.CONDUCTOR RESISTANCE: 2 ohm MAX.
6. PACKING: 1PC/POLYBAG W/ LABEL

**CONTROLLED**

Dim range (mm)	Tolerance +/- (mm)	<b>Qualtek Electronics Corp.</b>		
		<b>WCI DIVISION</b>		
		Part Number: <b>3021056-01M</b>		<b>RoHS Compliant</b>
0-1	0.15	Description: <b>USB 4P(A)/M - USB 4P(A)/F</b>		
1-6	0.20		UNIT: mm	
6-18	0.30			
18-50	0.50			
50-120	0.70	Drawn / Date	Checked / Date	Approved / Date
120-250	0.90	R. Nuti 09-25-17	09-25-17	LY / 09-25-17
250-500	1.20			