

MATERIAL		
COMPONENT NAME	BASE MATERIAL	FINISH
CASE	LCP, BLACK, UL94 V-0	
TERMINAL, WIRE LUG (GOLD)	BRASS	GOLD OVER NICKEL
TERMINAL, PC & RA (GOLD)	BRASS	GOLD OVER NICKEL IN CONTACT AREA, TIN OVER NICKEL IN SOLDER AREA
TERMINAL, VRA (GOLD)	BRASS	GOLD OVER NICKEL IN CONTACT AREA, TIN OVER NICKEL IN SOLDER AREA
TERMINAL, WIRE LUG (SILVER)	SILVER CLAD COPPER	SILVER OVER NICKEL
TERMINAL, PC (SILVER)	SILVER CLAD COPPER	SILVER OVER NICKEL
CONTACT (GOLD)	COPPER ALLOY OR BRASS	GOLD OVER NICKEL
CONTACT (SILVER)	SILVER CLAD COPPER OR COPPER	SILVER OVER NICKEL
FRAME	STEEL	TIN OVER COPPER
SPRING	MUSIC WIRE	
PLUNGER BUTTON	NYLON 6/6, BLACK, RED OR BLUE, UL94 HB (EXTENDED) OR UL94V-2 (FLUSH)	
SUPPORT BRACKET (RA*ES VERSIONS ONLY)	BRASS	TIN OVER COPPER
SUPPORT BRACKET, VRA (B&C BUSHINGS ONLY)	STEEL	TIN OVER COPPER
BUSHING	BRASS	NICKEL OVER COPPER
MOUNTING NUT	BRASS	NICKEL
LOCKWASHER	STEEL	NICKEL
ES HOUSING	NYLON 6/6, NATURAL, UL94 V-2	
ES BOOT	VINYL PLASTISOL, BLACK	

PART NUMBER MATRIX									
MODEL	ACTUATOR	POLES	RATING	FUNCTION	PLATING	TERMINATIONS	PROCESS SEAL	BUTTON COLOR	04
TPC	BLANK=EXTENDED	1	1=GOLD .4VA	C=SPST MOMENTARY	G=GOLD	BLANK=WIRE LUG	ES=PROCESS SEALED ²	0=BLACK	
		2	3=SILVER 1 AMP ¹	F=SPDT MOMENTARY	BLANK=SILVER ¹	PC=PRINTED CIRCUIT		2=RED	
				M=DPST MOMENTARY		RA=RIGHT ANGLE ²		6=BLUE	
				R=DPDT MOMENTARY		VRA=VERTICAL RIGHT ANGLE ³			

NOTES:
 1. SILVER ONLY AVAILABLE IN WIRE LUG AND PC TERMINATIONS
 2. RAES AVAILABLE WITH B AND C BUSHINGS ONLY
 3. VRA ONLY AVAILABLE IN SINGLE POLE

SPECIFICATIONS	
RATING	GOLD: .4VA MAX. @ 20VDC OR PEAK AC RESISTIVE SILVER: 1A @ 125VAC OR 28 VDC RESISTIVE
INITIAL TERMINATION RESISTANCE	20 MILLIOHMS MAX.
INSULATION RESISTANCE	1,000 MEGOHMS MIN @ 500 VDC
DIELECTRIC STRENGTH	1,000 VOLTS RMS AT SEA LEVEL
TIMING	BREAK BEFORE MAKE
PLUNGER TRAVEL	.030
ACTUATION FORCE	50 TO 400 GRAMS
LIFE EXPECTANCY	.4 VA, 1 POLE: 100,000 .4 VA, 2 POLES: 80,000 1 A, 1 POLE: 60,000 1 A, 2 POLES: 50,000
OPERATING TEMPERATURE	-30°C TO +65°C
STORAGE TEMPERATURE	-30°C TO +65°C
TERMINAL SEAL	SINGLE POLE: EPOXY DOUBLE POLE: EPOXY OPTIONAL

- TERMINAL NUMBERS ARE FOR REFERENCE ONLY AND DO NOT APPEAR ON SWITCHES.
 - ALL MATERIALS AND FINISHES COMPLY WITH EU DIRECTIVE 2002/95/EC OF 27JAN2003 (ROHS).
 - DISPOSABLE BOOT SUPPLIED WITH ES VERSIONS. BOOT TO BE PLACED OVER BUSHING BEFORE SOLDER WASHING.
- 4 CENTER TERMINAL PRESENT ON DOUBLE THROW SWITCHES ONLY.
 5 OBSOLETE.

TE P/N	ALCO P/N	POLES	THROWS	PLATING	TERMINALS	PROCESS SEALED	BUTTON COLOR	FUNCTION				CONNECTED TERMINALS	
								OFF	MOM	ON	OFF	1-2	2-3
1825100-1	TPF11CGPC004	1	1	GOLD	PC	NO	BLACK	OFF	MOM	OFF	OFF	1-3	
1825100-2	TPF11CGPC204	1	1	GOLD	PC	NO	RED	OFF	MOM	OFF	OFF	1-3	
1825100-3	TPF11CGPCES004	1	1	GOLD	PC	YES	BLACK	OFF	MOM	OFF	OFF	1-3	
1825100-4	TPF11CGRA004	1	1	GOLD	RIGHT ANGLE	NO	BLACK	OFF	MOM	OFF	OFF	1-3	
1825100-5	TPF11CGRA204	1	1	GOLD	RIGHT ANGLE	NO	RED	OFF	MOM	OFF	OFF	1-3	
1825100-6	TPF11CGRA604	1	1	GOLD	RIGHT ANGLE	NO	BLUE	OFF	MOM	OFF	OFF	1-3	
1825100-7	TPF11FGPC004	1	2	GOLD	PC	NO	BLACK	ON	MOM	OFF	OFF	1-2, 2-3	
1825100-8	TPF11FGPC204	1	2	GOLD	PC	NO	RED	ON	MOM	OFF	OFF	1-2, 2-3	
1825100-9	TPF11FGPC604	1	2	GOLD	PC	NO	BLUE	ON	MOM	OFF	OFF	1-2, 2-3	
1825100-0	TPF11FGPCES004	1	2	GOLD	PC	YES	BLACK	ON	MOM	OFF	OFF	1-2, 2-3	
1825100-1	TPF11FGRA004	1	2	GOLD	RIGHT ANGLE	NO	BLACK	ON	MOM	OFF	OFF	1-2, 2-3	
1825100-2	TPF13C004	1	1	SILVER	WIRE LUG	NO	BLACK	OFF	MOM	OFF	OFF	1-3	
1825100-3	TPF13C204	1	1	SILVER	WIRE LUG	NO	RED	OFF	MOM	OFF	OFF	1-3	
1825100-4	TPF13F204	1	2	SILVER	WIRE LUG	NO	RED	ON	MOM	OFF	OFF	1-2, 2-3	
1825100-5	TPF13F604	1	2	SILVER	WIRE LUG	NO	BLUE	ON	MOM	OFF	OFF	1-2, 2-3	
1825100-6	TPF21MGPC004	2	1	GOLD	PC	NO	BLACK	OFF	MOM	OFF	OFF	1-3, 4-6	
1825100-7	TPF21RGRA004	2	2	GOLD	RIGHT ANGLE	NO	BLACK	ON	MOM	OFF	OFF	1-2, 4-5, 2-3, 5-6	
1825100-8	TPF23M004	2	1	SILVER	WIRE LUG	NO	BLACK	OFF	MOM	OFF	OFF	1-3, 4-6	

THIS DRAWING IS A CONTROLLED DOCUMENT. DIMENSIONS: INCHES. TOLERANCES UNLESS OTHERWISE SPECIFIED: 0 PLC ± .010, 1 PLC ± .010, 2 PLC ± .010, 3 PLC ± .010, 4 PLC ± .010. ANGLES ± .5°.

STE TE Connectivity
 PUSHBUTTON SWITCH, TPF SERIES

SIZE: A1, CAGE CODE: 00779, DRAWING NO: 1825100, WEIGHT: 1.0g, RESTRICTED TO: CUSTOMER DRAWING, SCALE: 4:1, SHEET: 1 OF 5, REV: B

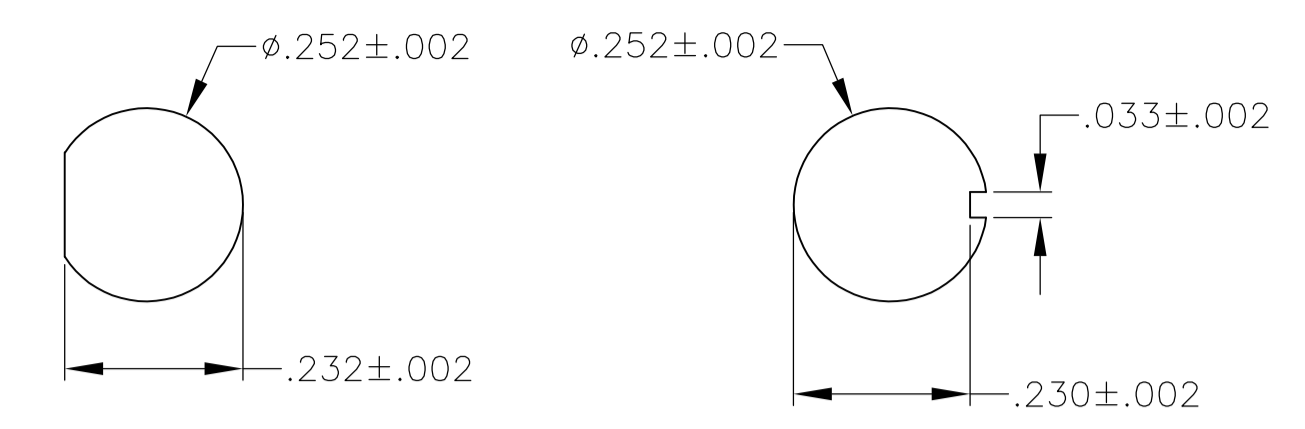
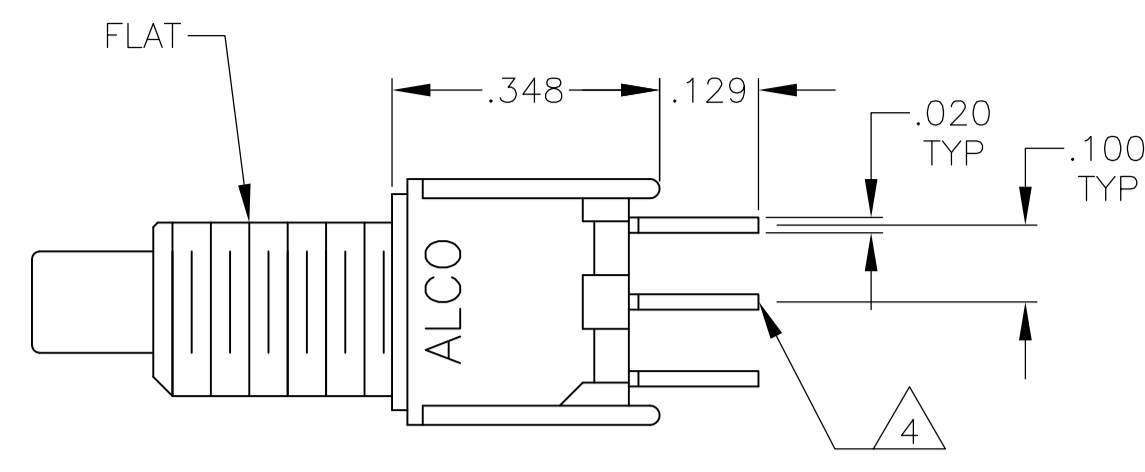

RECOMMENDED PANEL LAYOUTS

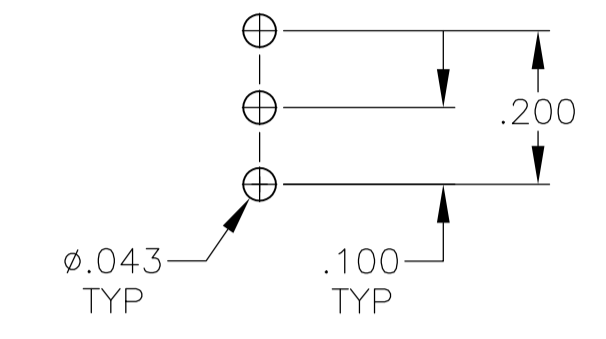
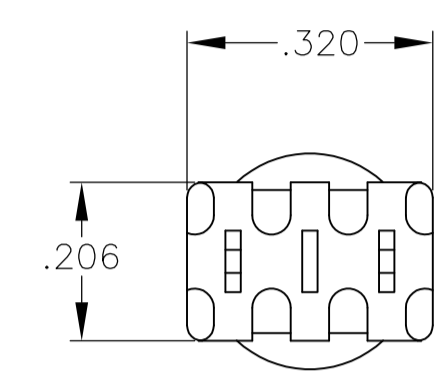
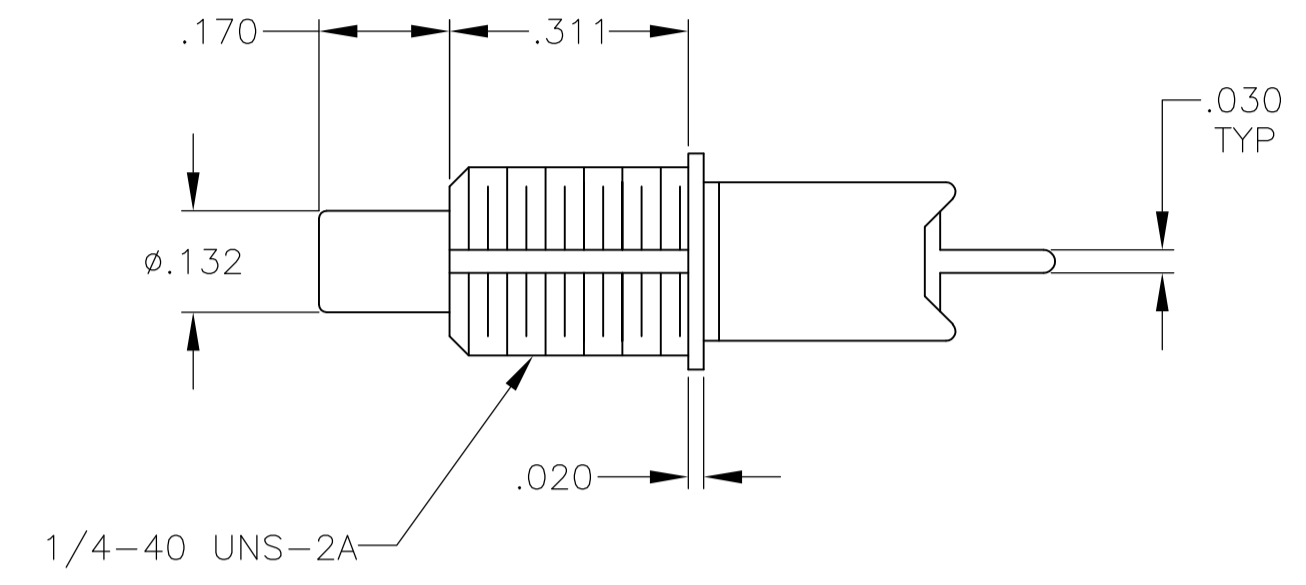
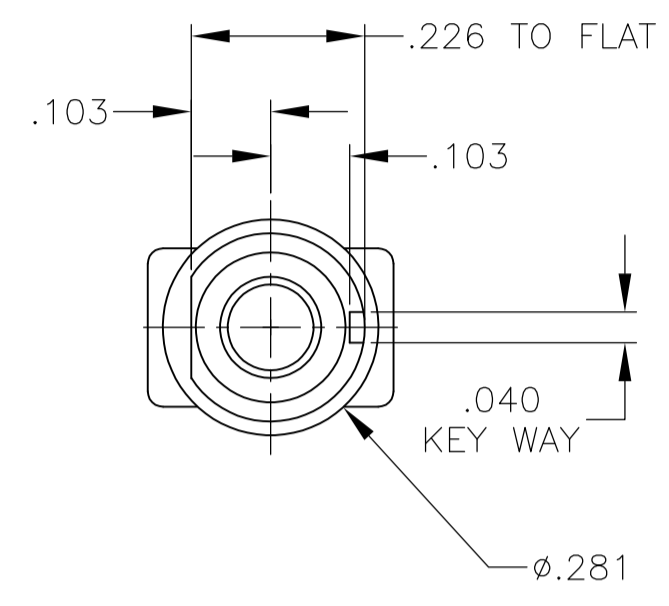

RECOMMENDED PCB LAYOUT
TOLERANCES +/- .002

TPF11CGPC, TPF11FGPC

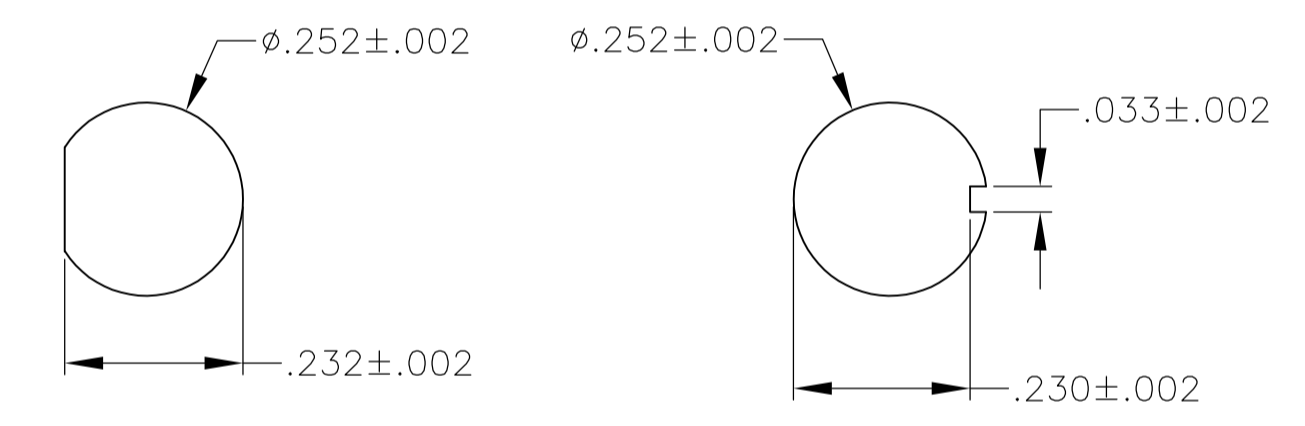
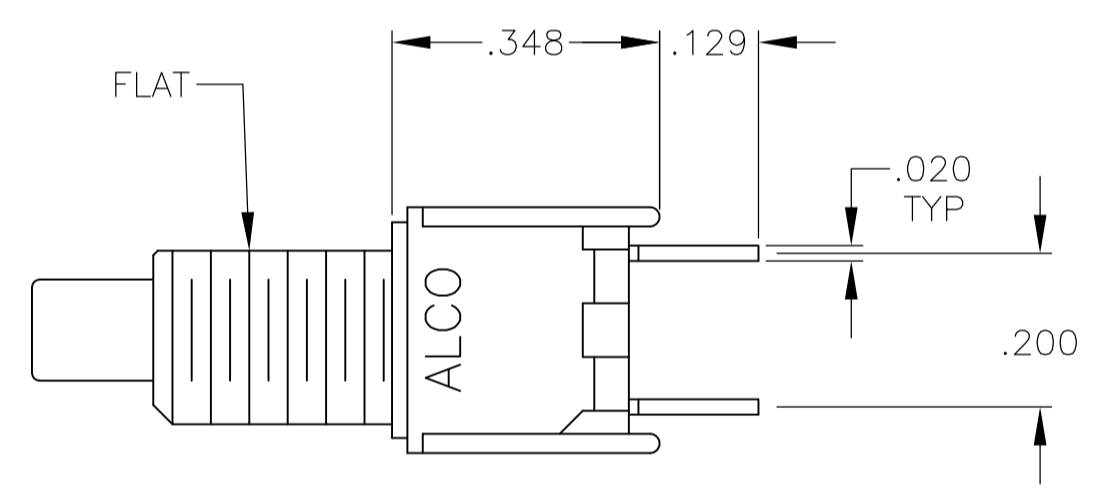

RECOMMENDED PANEL LAYOUTS

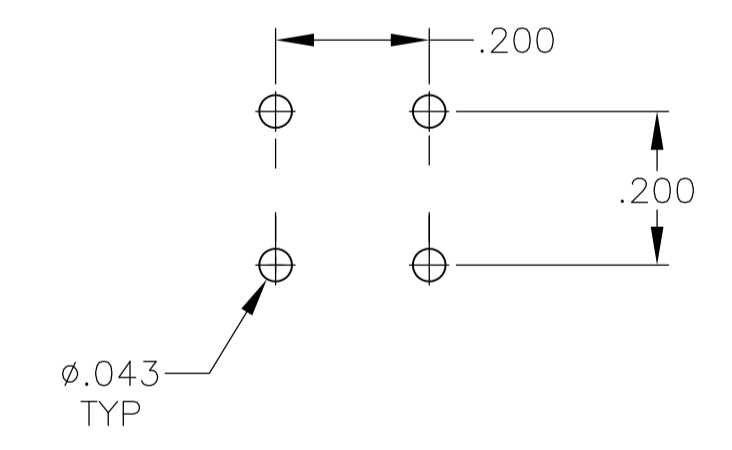
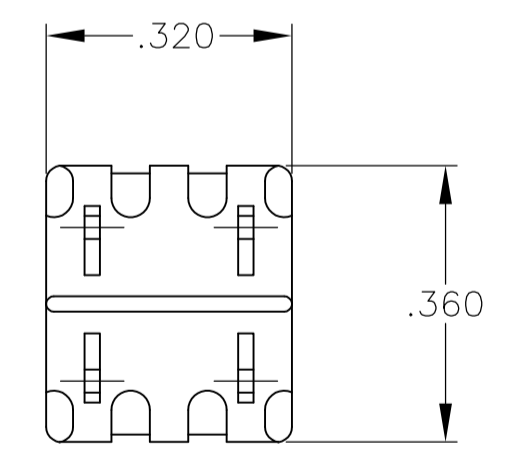
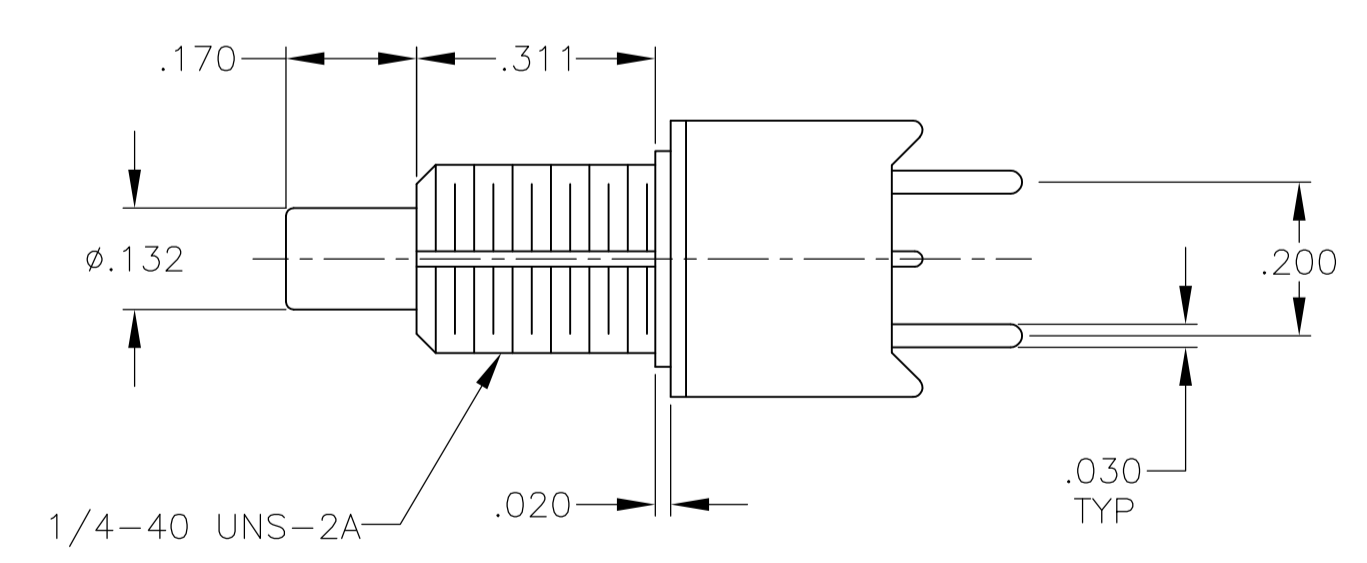
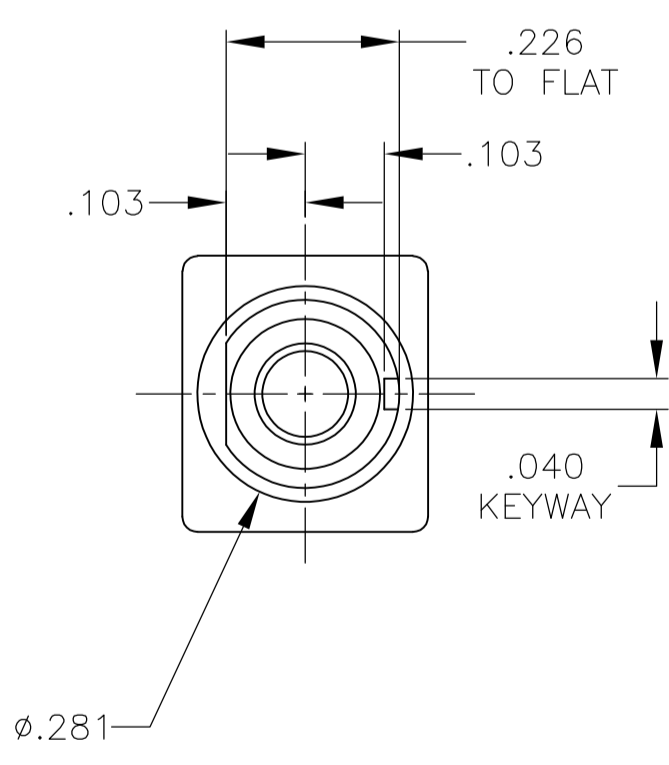

RECOMMENDED PCB LAYOUT
TOLERANCES +/- .002

TPF21RGPC

THIS DRAWING IS A CONTROLLED DOCUMENT.		BIN RAGHU 12-7-05		TE Connectivity	
DIMENSIONS: INCHES		TOLERANCES UNLESS OTHERWISE SPECIFIED:			
0. PLC ± - 1. PLC ± - 2. PLC ± - 3. PLC ± .010 4. PLC ± - ANGLES ± °		APVD - PRODUCT SPEC - APPLICATION SPEC -		SIZE A1 CAGE CODE 00779 DRAWING NO. 1825100	
MATERIAL -		FINISH -		WEIGHT - CUSTOMER DRAWING	
				RESTRICTED TO - SCALE 4:1 SHEET 2 OF 5 REV B	

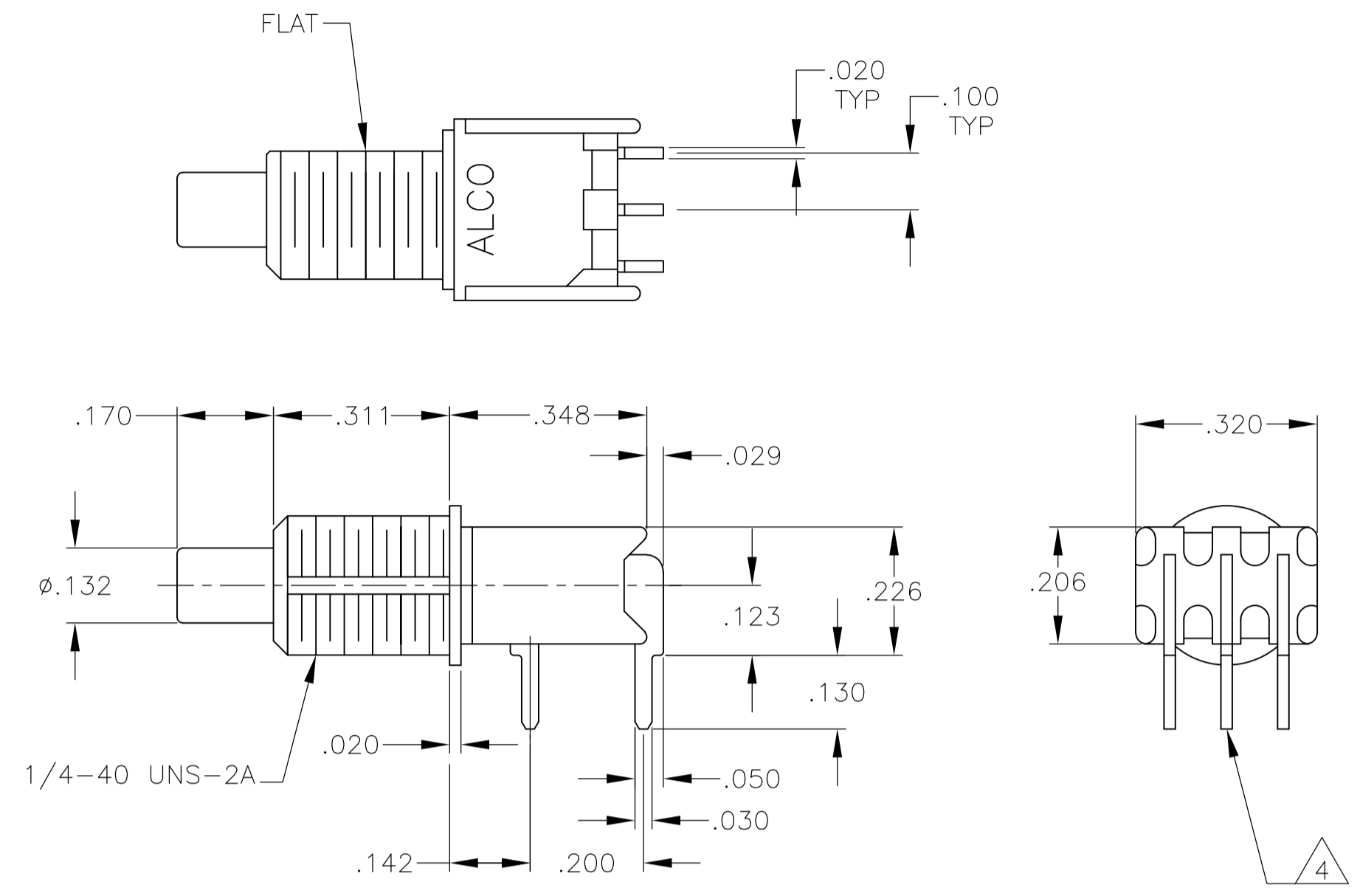
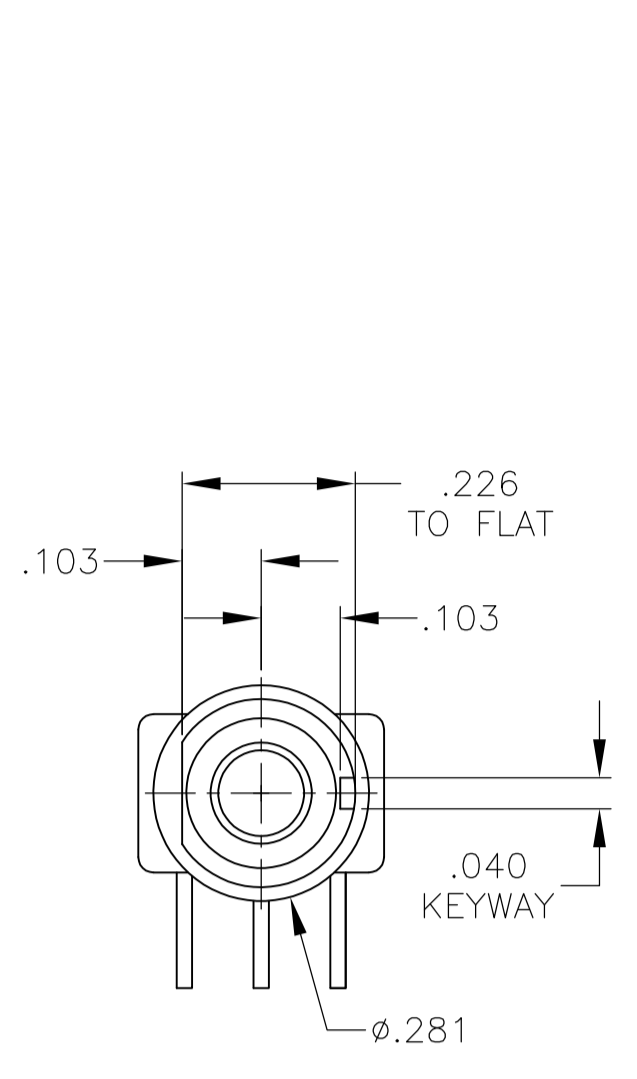

TPF11CGRA, TPF11FGRA

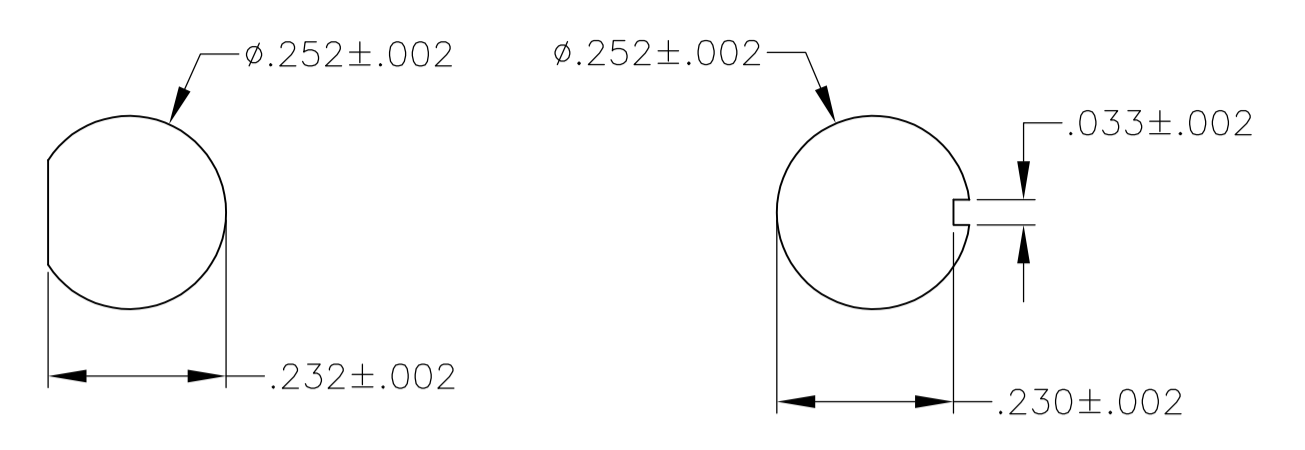

RECOMMENDED PANEL LAYOUTS

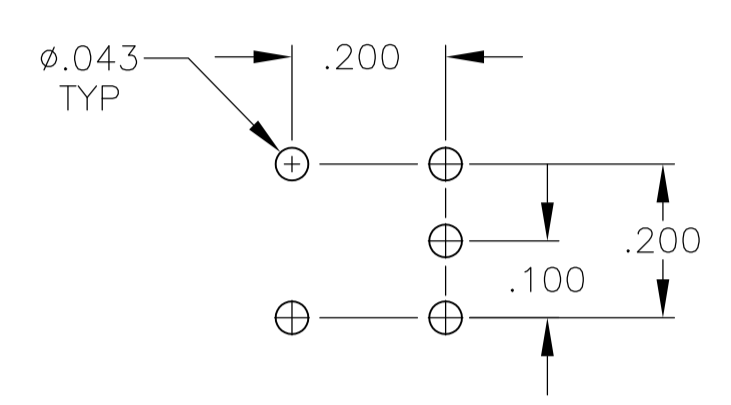

RECOMMENDED PCB LAYOUT
TOLERANCES +/- .002

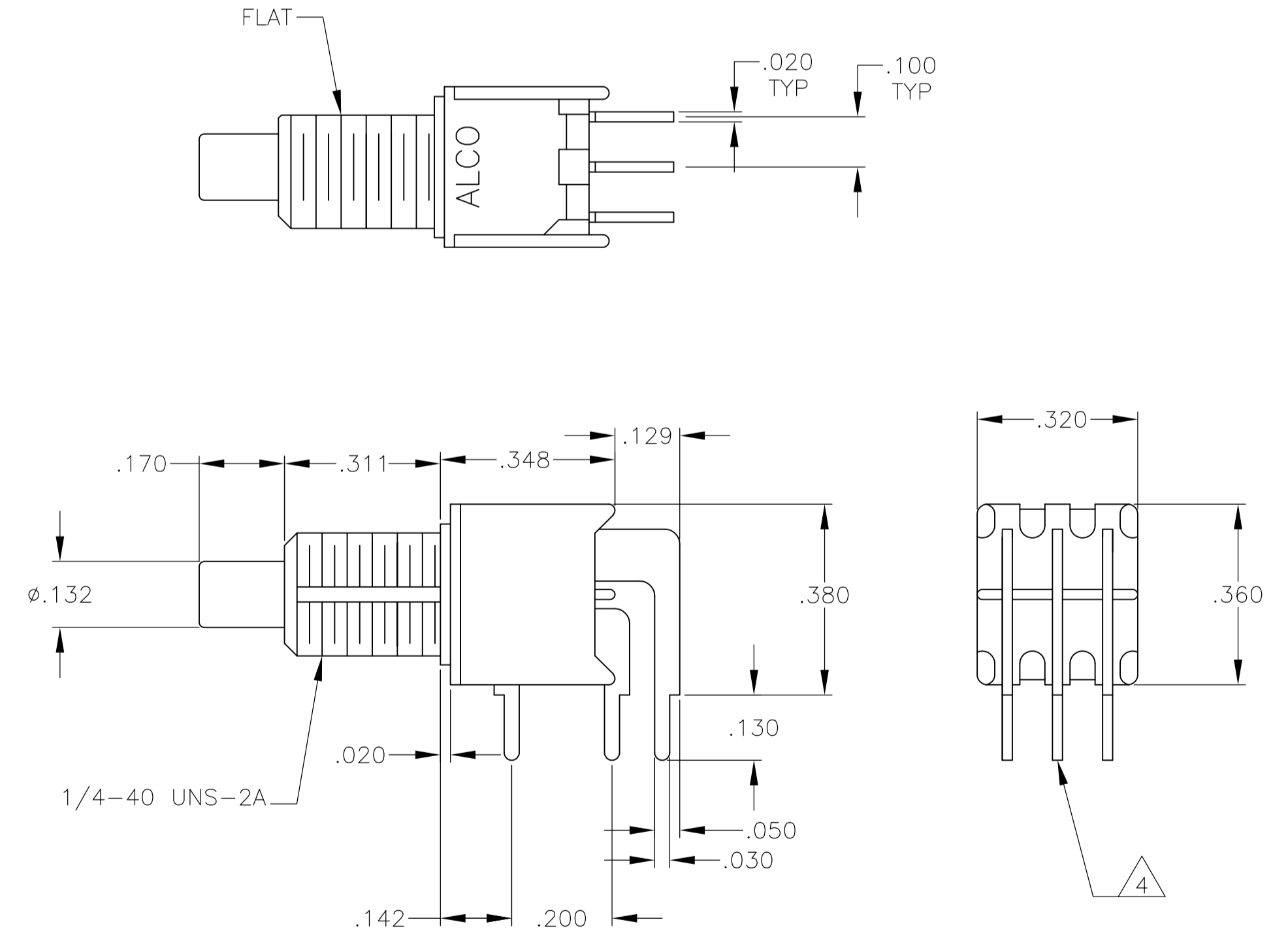
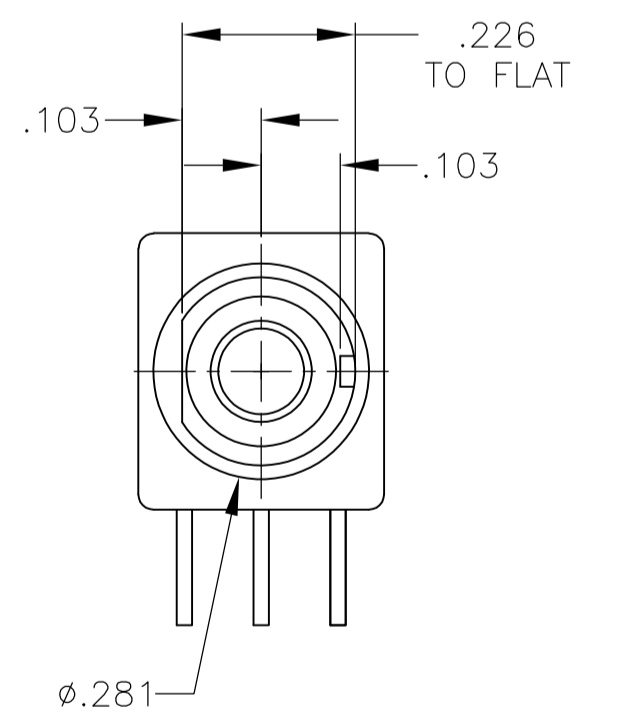

TPF21RGRA

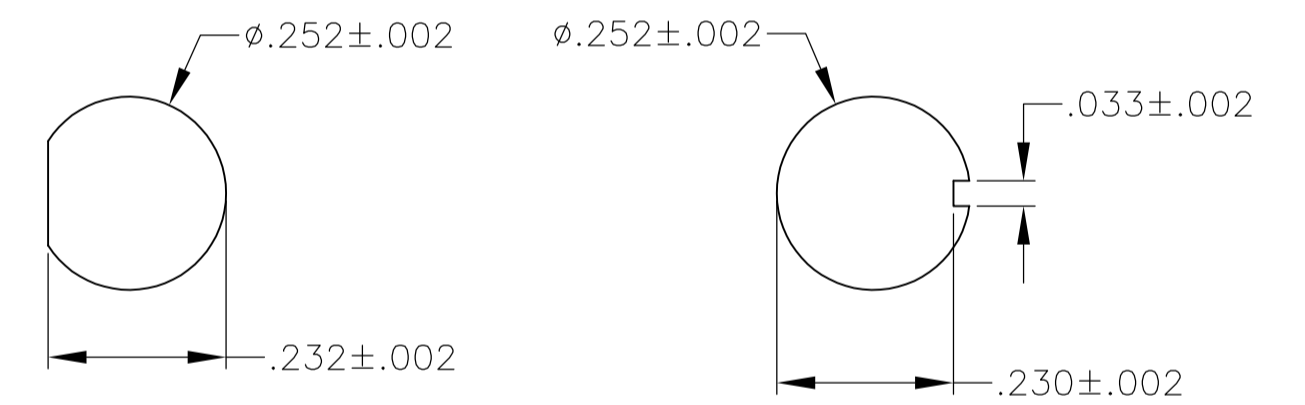

RECOMMENDED PANEL LAYOUTS

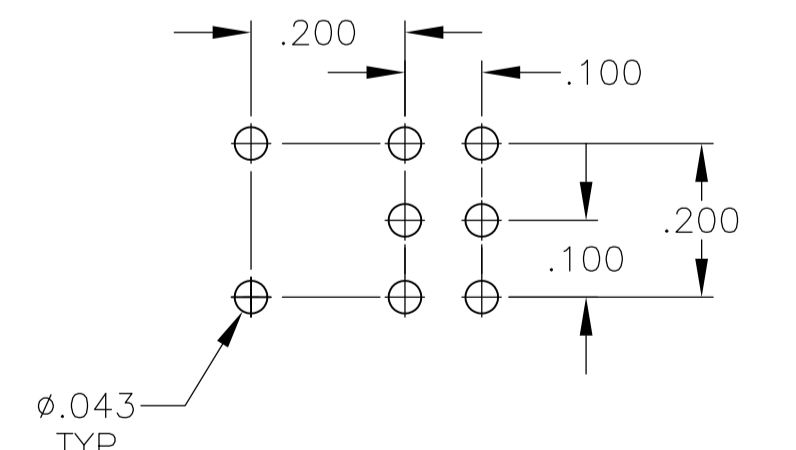

RECOMMENDED PCB LAYOUT
TOLERANCES +/- .002

THIS DRAWING IS A CONTROLLED DOCUMENT.		DIN RAGHU 12-7-05	TE Connectivity	
DIMENSIONS: INCHES		TOLERANCES UNLESS OTHERWISE SPECIFIED:	APVD	NAME
		0. PLC ± -	---	PRODUCT SPEC
		1. PLC ± -	---	APPLICATION SPEC
		2. PLC ± -	---	SIZE
		3. PLC ± .010	---	CAGE CODE
		4. PLC ± -	---	DRAWING NO
		ANGLES ± °	---	RESTRICTED TO
MATERIAL	FINISH	WEIGHT	A1 00779	1825100
CUSTOMER DRAWING		SCALE	4:1	SHEET 3 OF 5

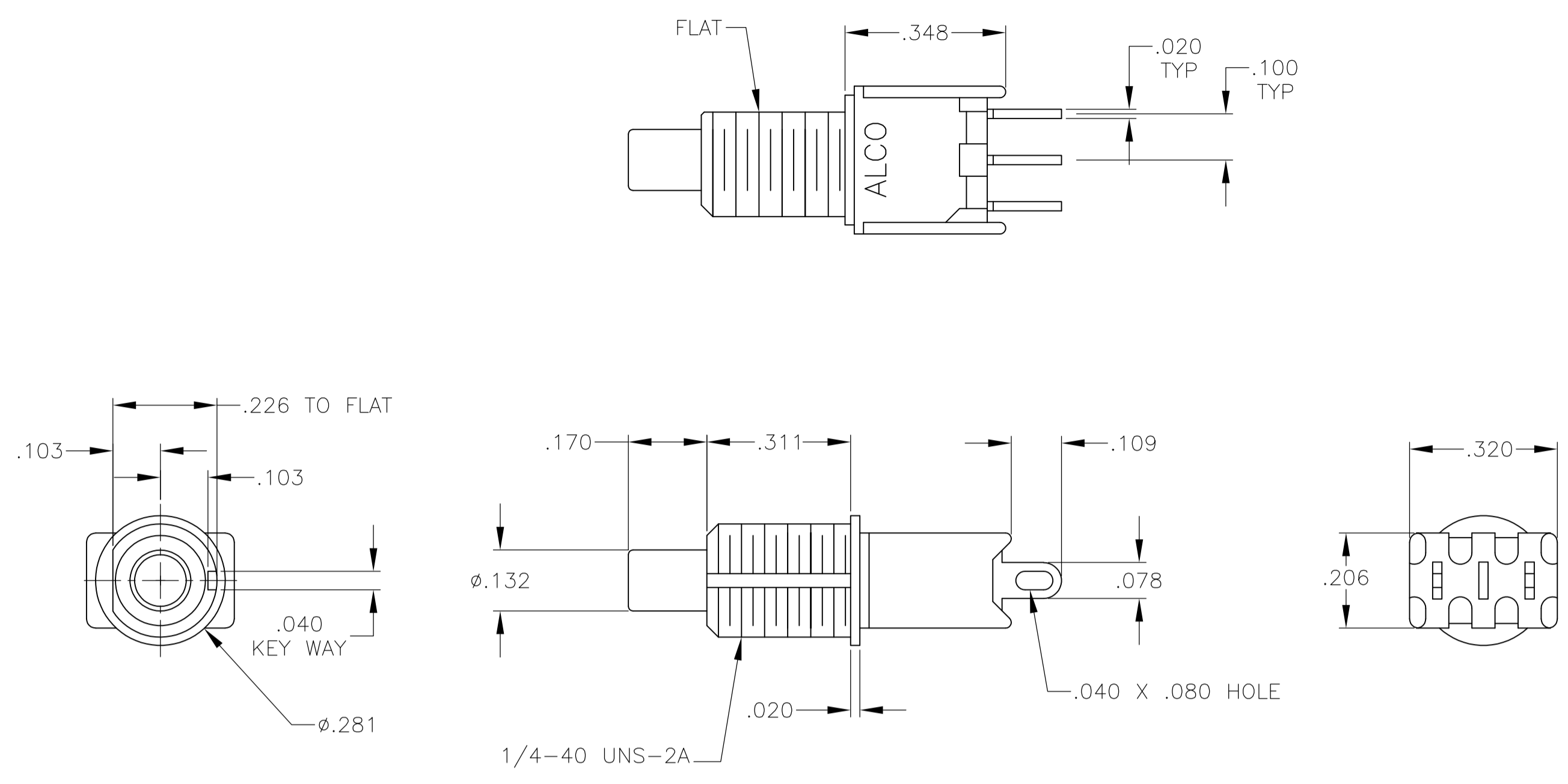

TPF13C, TPF13F

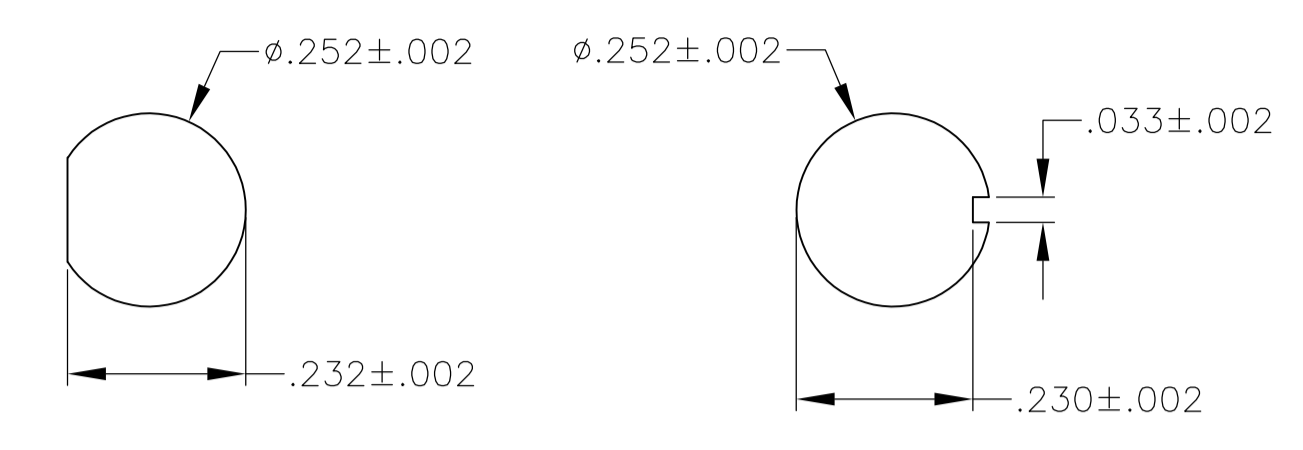

RECOMMENDED PANEL LAYOUTS

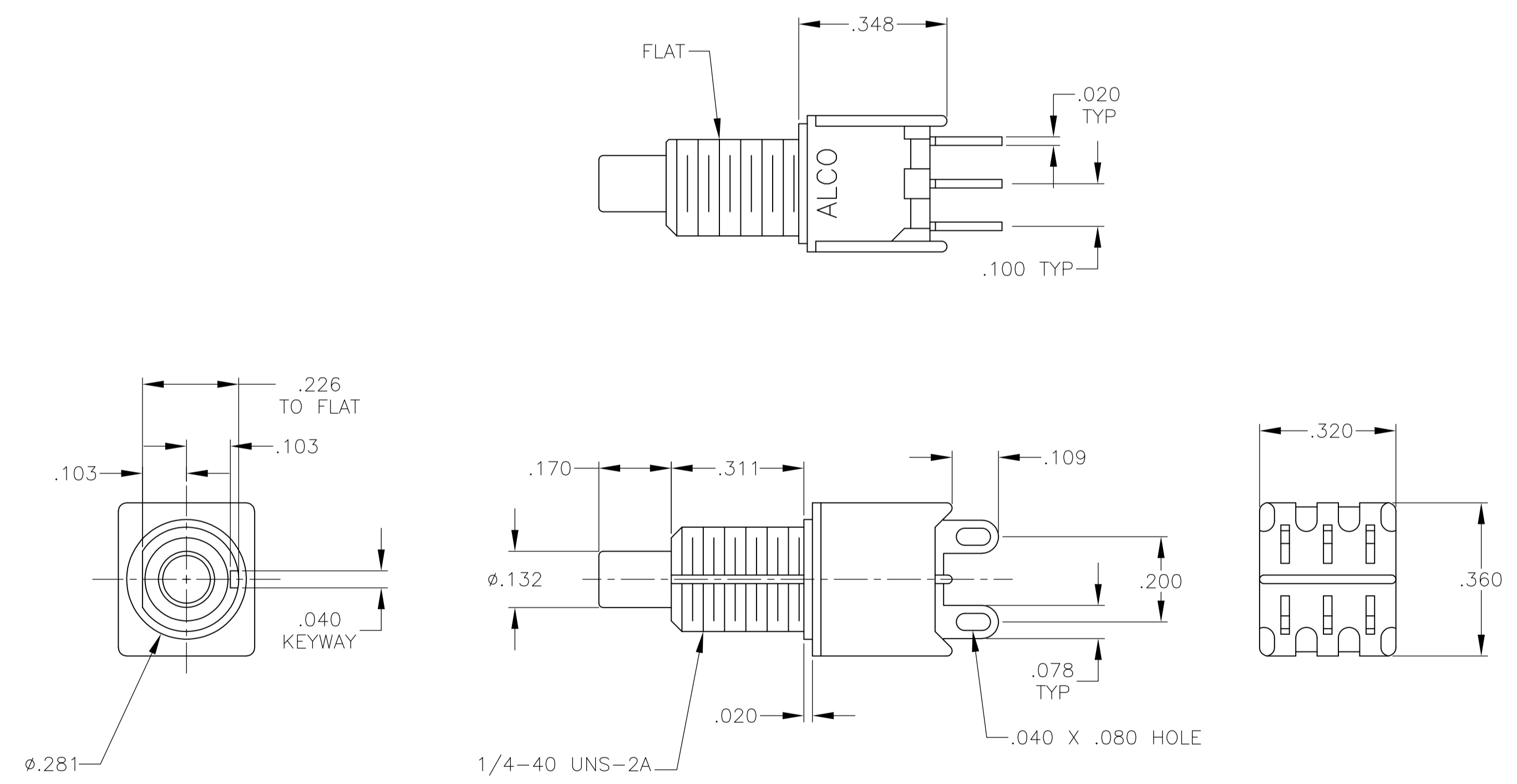

TPF23M

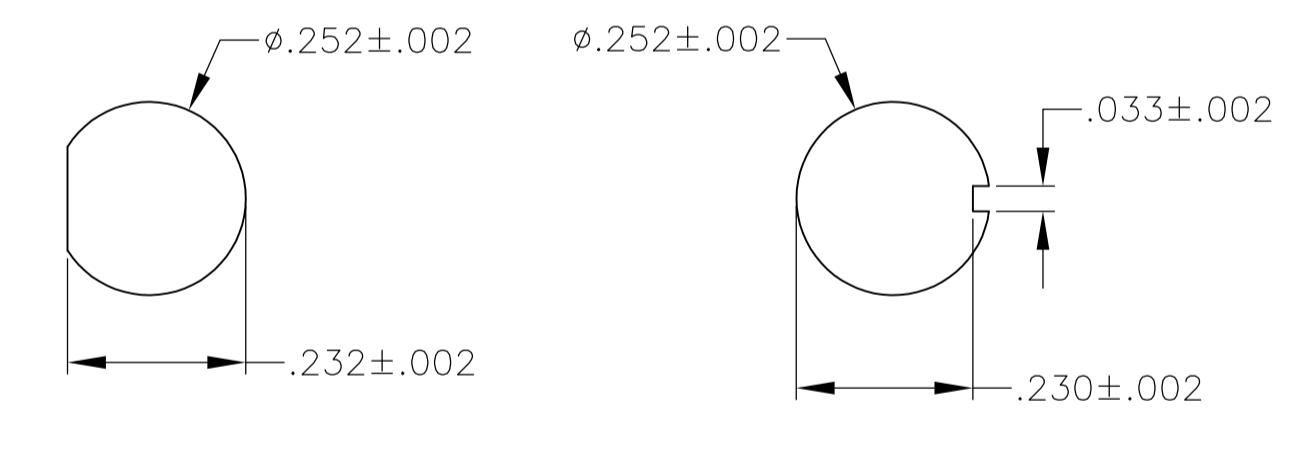

RECOMMENDED PANEL LAYOUTS

THIS DRAWING IS A CONTROLLED DOCUMENT.		DWG: RAGHU	12-7-05	TE Connectivity NAME: PUSHBUTTON SWITCH, TPF SERIES	
DIMENSIONS: INCHES		CHK: -	APVD: -		
TOLERANCES UNLESS OTHERWISE SPECIFIED: 0. PLC ± - 1. PLC ± - 2. PLC ± - 3. PLC ± .010 4. PLC ANGLES ± °		APPLICATION SPEC: -		RESTRICTED TO: -	
MATERIAL: -		WEIGHT: -		SIZE: A1	CAGE CODE: 00779
FINISH: -		CUSTOMER DRAWING		SCALE: 4:1	SHEET 4 OF 5

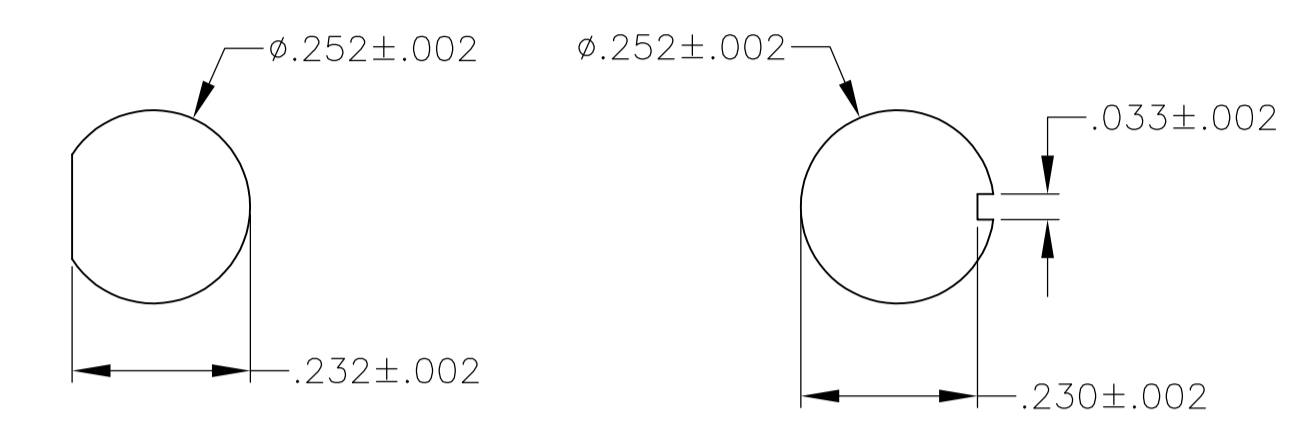
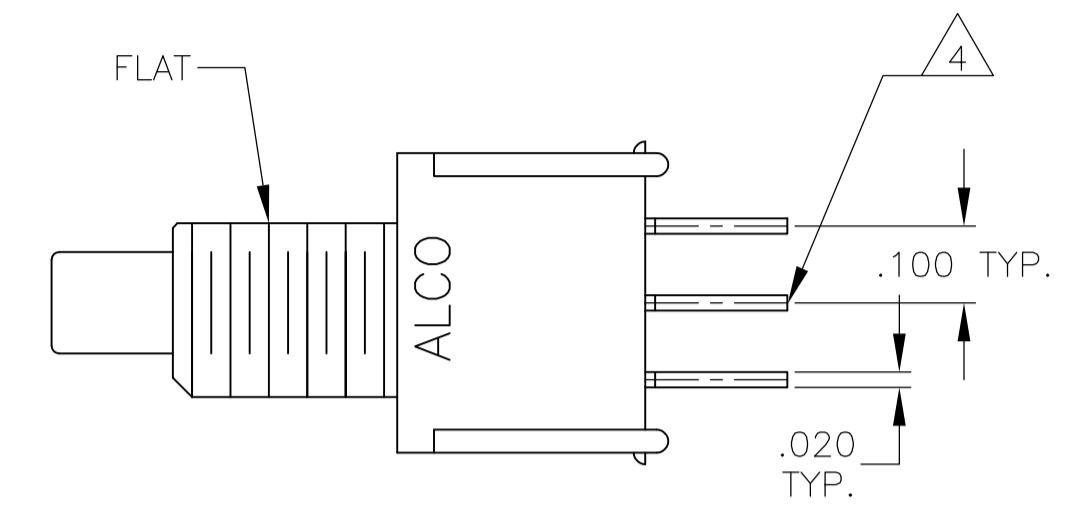

RECOMMENDED PANEL LAYOUTS

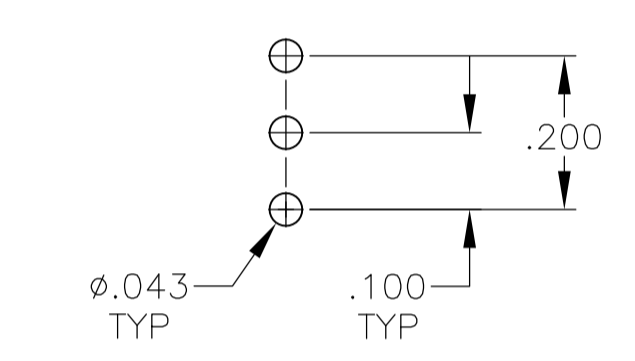
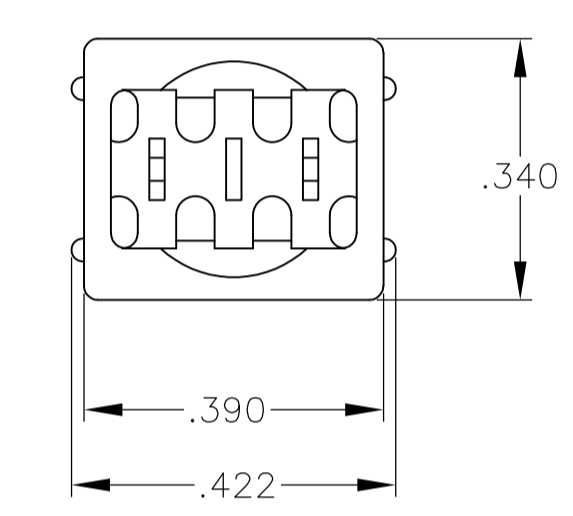
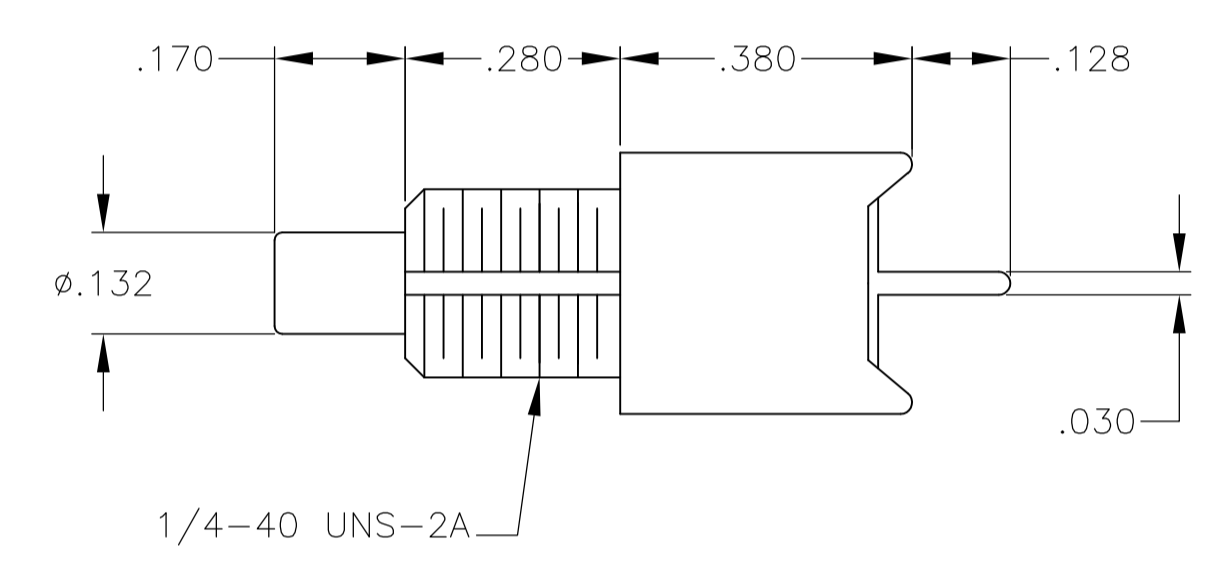
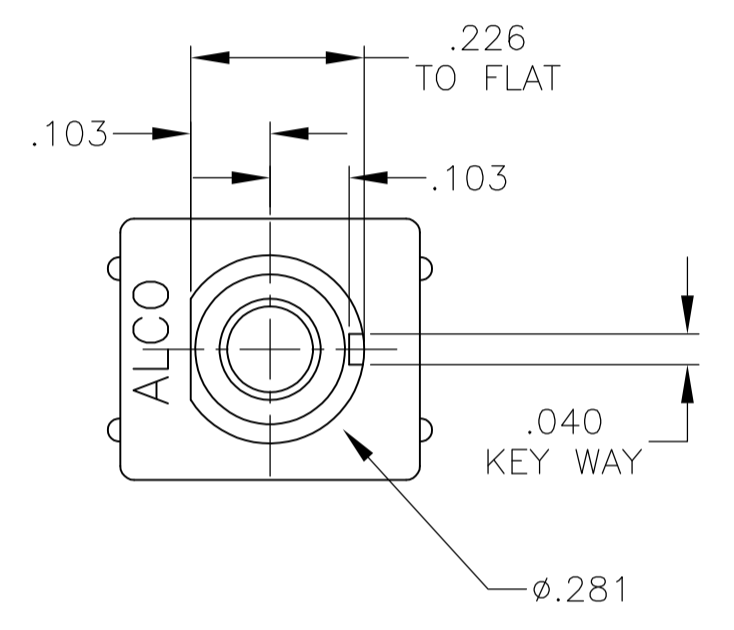

RECOMMENDED PCB LAYOUT
TOLERANCES +/- .002

TPF11CGPCES, TPF11FGPCES

THIS DRAWING IS A CONTROLLED DOCUMENT.		DIN	12-7-05	RAGHU	
DIMENSIONS: INCHES		CHK		APVD	
TOLERANCES UNLESS OTHERWISE SPECIFIED:		NAME			
0 PL	± .005	PRODUCT SPEC			
1 PL	± .005	APPLICATION SPEC			
2 PL	± .005	SIZE			
3 PL	± .010	CAGE CODE			
4 PL	± .010	DRAWING NO			
ANGLES	± .5°	RESTRICTED TO			
MATERIAL	FINISH	WEIGHT	A1 00779		1825100
CUSTOMER DRAWING		SCALE	4:1	SHEET	5 OF 5