

TMDS171 RGZ EVM

This document describes how to use and configure the TMDS171 RGZ EVM and provides recommendations for system hardware implementation. These recommendations are only guidelines and it is the designer's responsibility to consider all system characteristics and requirements. Engineers should refer to the TMDS171 datasheet ([SLLSEN7](#)) for technical details such as device operation, terminal description, and so forth.

Contents

1	Overview	2
	1.1 What is the TMDS171?	2
	1.2 What is the TMDS171 EVM?.....	2
	1.3 What is Included in the TMDS171 EVM?.....	2
	1.4 What Does This EVM Look Like?	3
2	Hardware Description	4
	2.1 Video Connectors for TMDS171 Ports.....	4
	2.2 Local I ² C Access	4
	2.3 Enable/Reset	5
	2.4 Power.....	5
	2.5 Jumper Configuration	6
	2.6 Component Population Configuration	7
	2.7 USB Interface via TUSB3410	8
3	Quick Start Guide	11
4	References	11
5	EVM Bill of Materials.....	12
6	EVM Schematics	14
7	EVM Layout	21
8	Total Phase Aardvark I2C Host Adapter Scripts	24

List of Figures

1	TMDS171 RGZ EVM	3
2	TMDS171 RGZ EVM REV B.....	3
3	TMDS171 RGZ EVM Block Diagram.....	4
4	Eye Scan Opening Tab	8
5	Register Status/Control Tab	9
6	TMDS171 Device with TMDS Clock Ratio set to 1/10	10
7	TMDS171 Device with TMDS Clock Ratio set to 1/40	11
8	HDMI Input Connector.....	14
9	TMDS171 RGZ Schematic (48-Pin QFN)	15
10	HDMI TX Connector	16
11	TMDS171 Select Options	17
12	RESET Circuit	18
13	Power Schematics (1.1-V and 3.3-V Regulators)	19
14	TUSB3410 Schematic	20
15	Layer 1 (Top)	21

HDMI is a registered trademark of HDMI Licensing, LLC.
Total Phase, Aardvark I2C/SPI are trademarks of Total Phase, Inc..

16	Layer 2 (GND)	21
17	Layer 3 (Power)	22
18	Layer 4 (Power)	22
19	Layer 5 (GND)	23
20	Layer 6 (Bottom).....	23

List of Tables

1	Aardvark I2C (J5) Pin-out.....	4
2	TMDS171 Target I ² C Address	5
3	SW1 DIP Switch Setting	6
4	EVM Bill of Materials.....	12

1 Overview

1.1 What is the TMDS171?

The TMDS171 is a digital video interface (DVI) or high-definition multimedia interface (HDMI®) retimer. The TMDS171 supports four TMDS channels, audio return channel (SPDIF_IN/ARC_OUT), and digital display control (DDC) interfaces. The TMDS171 supports signaling rates up to 6Gbps to allow for the highest resolutions of 4k/2k/60p 24-bits per pixel and up to WUXGA 16-bit color depth or 1080p with higher refresh rates. The TMDS171 can be configured to support the HDMI standard. The TMDS171 will automatically configure itself as a re-driver at low data rate (< 1.0Gbps) or as a re-timer above this data rate by default, or it can be set to re-driver-only or re-timer-only modes.

1.2 What is the TMDS171 EVM?

The TMDS171 EVM is a printed-circuit board (PCB) created to help customers evaluate the TMDS171 device for video applications with HDMI interfaces. This EVM can also be used as a hardware reference design for implementation of the TMDS171 in the RGZ package. PCB design and layout files can be provided upon request to provide PCB design illustrations of the routing and placement rules with a TMDS171 or DP159 RGZ component.

Note that the EVM design supports the TMDS171, DP159, and DP159 thru HDMI applications, so it contains many components that would not be needed by a typical TMDS171 application. A separate reference design specific to TMDS171 and DP159 are available for customers.

1.3 What is Included in the TMDS171 EVM?

The major components of the EVM are as below:

- TMDS171RGZ
- Standard HDMI source connector (receptacle)
- Standard HDMI sink connector (receptacle)
- DC power regulators
- I²C programming interface for external I²C host connection
- USB interface (utility available)

1.4 What Does This EVM Look Like?

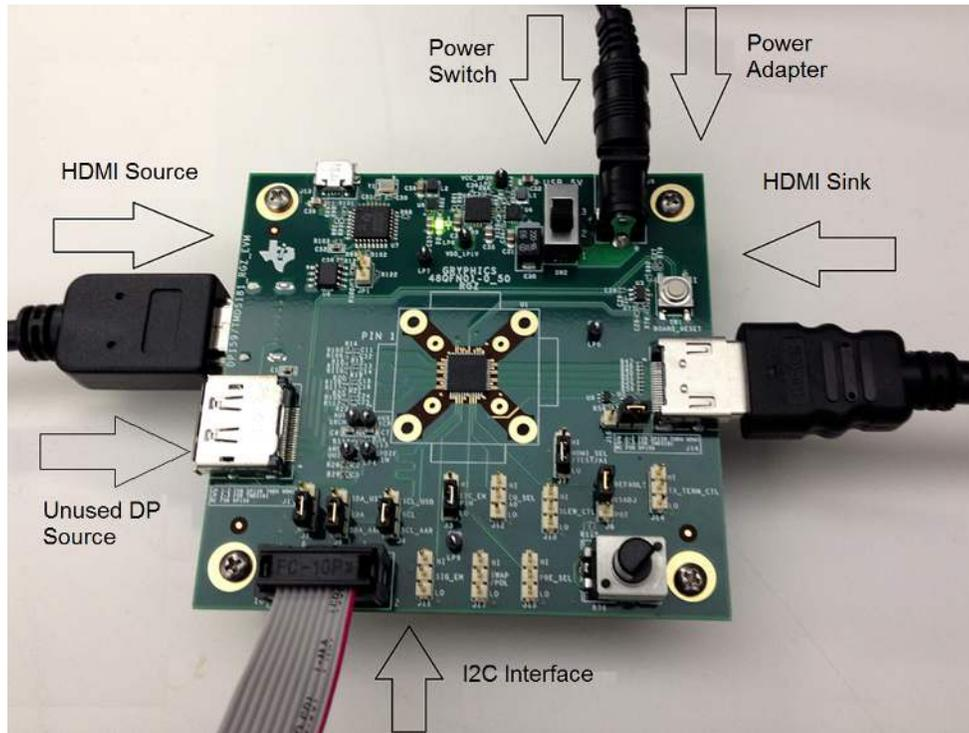

Figure 1. TMS171 RGZ EVM

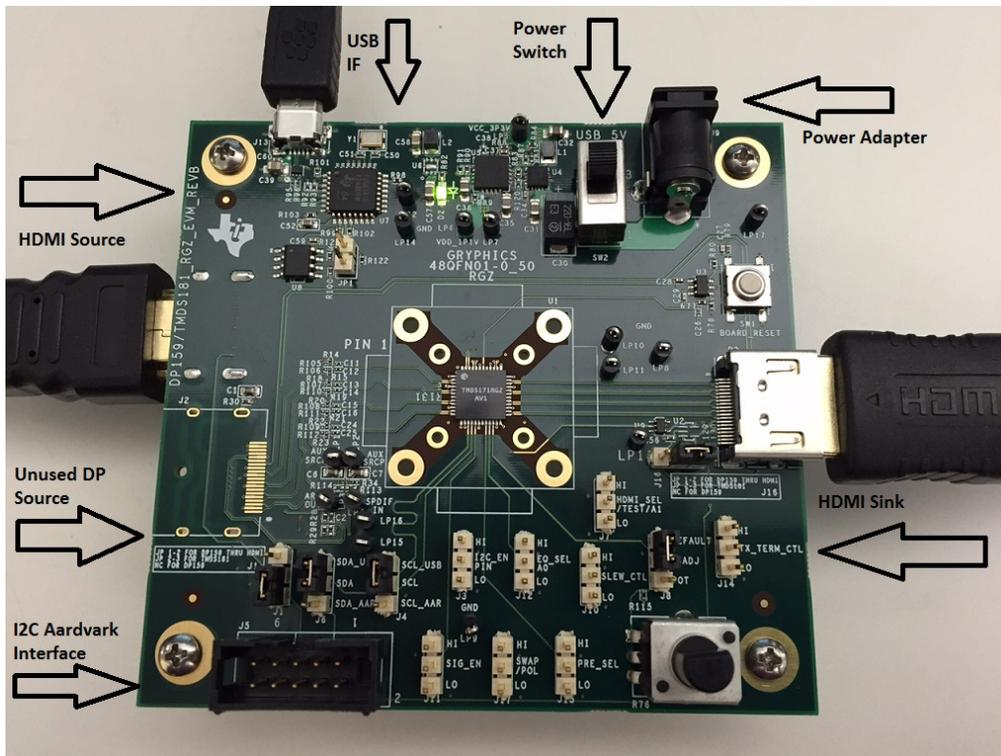

Figure 2. TMS171 RGZ EVM REV B

2 Hardware Description

Figure 3 illustrates the EVM block diagram.

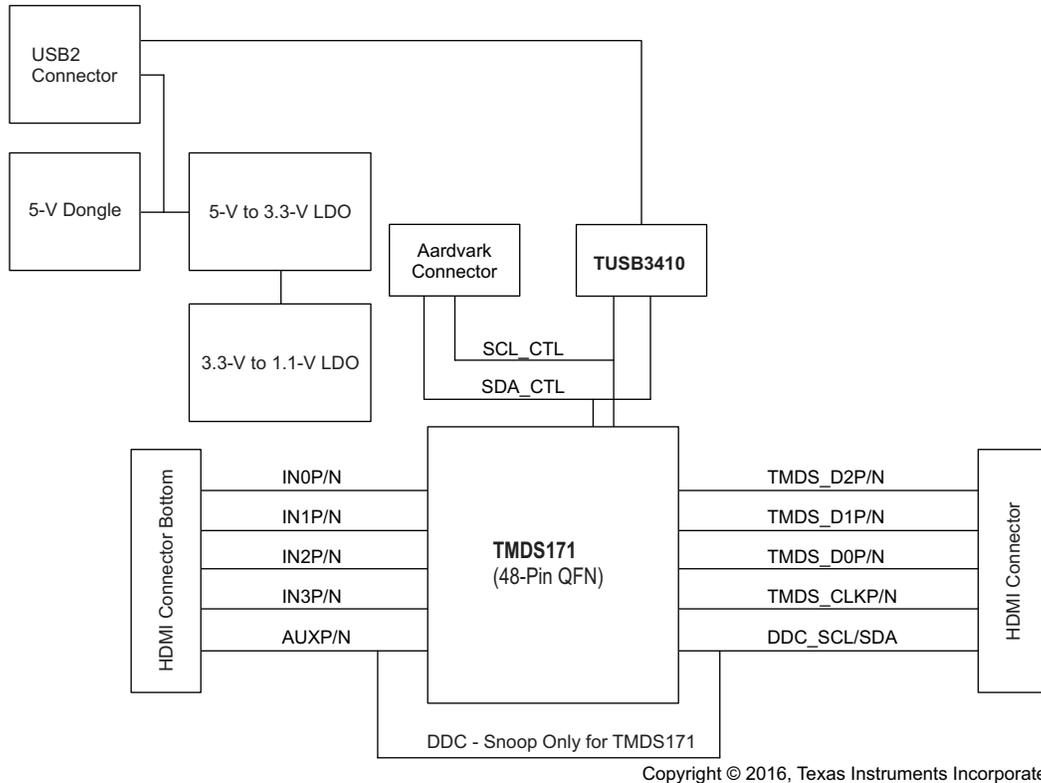

Figure 3. TMDS171 RGZ EVM Block Diagram

2.1 Video Connectors for TMDS171 Ports

The EVM has two HDMI connections for video. P1 and P2 are standard HDMI connectors (Molex 4715-10001). There is a third video connection on the board for DisplayPort (J2), this function is not supported on the TMDS171RGZ EVM.

2.2 Local I²C Access

The J5 input connector provides access to the local I²C signal of the TMDS171. Note that I²C signal levels should be at 3.3 V when the I²C interface is accessed through the connector.

A standalone external I²C host can be connected via J5 for debug and control purposes. An example of an external I²C Host controller is the Total Phase™ Aardvark I2C/SPI™ Host Adapter (Total Phase Part#: [TP240141](#)). Sample scripts for this I²C host controller are provided by request.

Table 1. Aardvark I2C (J5) Pin-out

J5 Pin #	Description	J5 Pin #	Description
1	SCL_CTL	2	GND
3	SDA_CTL	4	NC
5	NC	6	NC
7	NC	8	NC
9	NC	10	GND

Table 2. TMDS171 Target I²C Address

TMDS171 I ² C ⁽¹⁾ Target Address							
Bit 7 (MSB)	Bit 6	Bit 5	Bit 4	Bit 3	Bit 2	Bit 1	Bit 0 (W/R)
A6	A5	A4	A3	A2	A1	A0	
1	0	1	1	1	1	0	0/1
7 Bit Address = 5Eh							

⁽¹⁾ The target I²C address for TMDS171 can be modified by the EVM jumper settings.

2.3 Enable/Reset

There are three device enable or reset options to use with the EVM.

1. Supervisor circuitry option

This is the default configuration on the TMDS171 EVM. The enable (EN) signal is held low until the power good (PG) from the 3.3-V voltage regulator reaches a stable high voltage level and then is released high.

2. RC timing option

C26 external capacitor and internal resistor are used to control the EN ramp time after the device is powered on. C26 is DNI (Do Not Install option), by default. C26 must be installed and R77 must be uninstalled to enable this option.

3. External control option

A push button (SW1) is provided for manual control of the TMDS171 EN/OE input.

2.4 Power

A DC Power Jack (J9) to accept a 5-V wall power adapter is provided on the EVM. The DC Power Jack (CUI Inc. PJ-202AH) has an inner diameter of 2.1 mm and an outer diameter of 5.5 mm. The tip of the 5-V power supply must be positive. A 5-V power supply of at least 1.0 A that meets the above requirements can be used to power the TMDS171 RGZ EVM. Power is provided to the EVM when SW2 is set to position 1.

CAUTION

Do not plug in any power source higher than the configured voltage (5 V).

Alternately, it is possible to power the EVM by connecting a USB Micro cable to a host and setting SW2 to position 3. Using the EVM in this manner may exceed USB compliance requirements for power consumption.

Note that to prevent any back-driving of 5 V in the system, most TMDS171 EVMs have been modified to receive 5 V from the HDMI source connection to drive the Board_5V. This has been done by removing U6 and installing R104 on the EVMs.

2.5 Jumper Configuration

Jumpers are provided to operate the device and EVM in different configurations.

Table 3. SW1 DIP Switch Setting

DIP SW No	Signal Name	Description	Default Config
J1	HPD_SRC	JP 1–2 for DP159 thru HDMI JP 2–3 for TMDS171 NC for DP159	JP 2–3 Allows for 3.3 V to 5 V transition of HPD_SRC signal
J3	I2C_EN_PIN	JP 1–2 for I2C ENABLE JP 2–3 for PIN STRAP NC – N/A	JP 2–3 Enables device configuration from I ² C or pin straps
J4	SCL	JP 1–2 for USB IF to I2C JP 2–3 for EXT IF to I2C NC – N/A	JP 1–2 USB I ² C Interface
J6	SDA	JP 1–2 for USB IF to I2C JP 2–3 for EXT IF to I2C NC – N/A	JP 1–2 USB I ² C Interface
J7	HDMI_SEL_TEST_A1	JP 1–2 for: <ul style="list-style-type: none"> I2C Addr bit A1 = 1, when I2C_EN = H Test mode, when I2C_EN = L JP 2–3 for: <ul style="list-style-type: none"> I2C Addr bit A1 = 0, when I2C_EN = H Normal mode, when I2C_EN = L NC for weak internal pulldown (Normal mode)	JP 2–3
J8	VSADJ	JP 1–2 for 7 k JP 2–3 for adjustable resistance NC – N/A	JP 1–2 <i>The default value is 4.64 kΩ early EVMs (prior to revision B)</i>
J10	SLEW_CTL	JP 1–2 for fastest data rate JP 2–3 for 20 ps slow NC for 40 ps slow	NC
J11	SIG_EN	JP 1–2 for Signal Detect Enabled JP 2–3 for Signal Detect Disabled NC for internal pulldown (Signal Detect Disabled)	NC
J12	EQ_SEL_A0	JP 1–2 for: <ul style="list-style-type: none"> I2C Addr bit A0 = 1, when I2C_EN = H Fixed EQ at 14 dB at 3G, when I2C_EN = L JP 2–3 for: <ul style="list-style-type: none"> I2C Addr bit A0 = 0, when I2C_EN = H Fixed EQ at 7.5 dB at 3G, when I2C_EN = L NC for Adaptive EQ	NC
J14	TX_TERM_CTL	JP 1–2 for no transmit term JP 2–3 for transmit term in 150–300 ohm NC for auto select of term	NC
J15	PRE_SEL	JP 1–2 for –5 dB JP 2–3 for –2.5 dB NC for 0 dB	NC
J16	CEC_CTL	JP 1–2 for DP159 thru HDMI JP 2–3 for TMDS171 NC for DP159	JP 2–3 Shorts HDMI_CEC_SRC to HDMI_CEC_SINK
J17	SWAP_POL	JP 1–2 for RX Polarity Swap (Retimer Mode Only) JP 2–3 for RX Lane Swap NC for normal	NC

2.6 Component Population Configuration

To allow the TMDS171 EVM to support both the TMDS171 RGZ device and the DP159 RGZ device, there are many components that must be removed, placed, or modified, depending on the board configuration. Here is a summary of the component configuration for the TMDS171. In addition, the unused source receptacle can be depopulated.

Function	Reference Designator	TMDS171
DIFFERENTIAL PAIR - IN	C11, C12, C13, C14, C15, C16, C24, C25	populated with 0 Ω
DIFFERENTIAL PAIR - HDMI IN	R14, R15, R18, R19, R20, R21, R22, R23	populated with 0 Ω
SDA / SCL - HDMI	R24, R25	populated with 0 Ω
DIFFERENTIAL PAIR - DP IN	R112, R109, R111, R108, R110, R107, R106, R105	not populated
SDA / SCL / HPD - DP	R33, R31, R32	not populated
ARC / SPDIF to DP	C2, C3	not populated
ARC / SPDIF to HDMI	C4, C5, C6, C7, R34	populated with 1 μ F / 0 Ω
ARC / SPDIF SHORT	R113, R114	not populated
PULL UP DIFFERENTIAL PAIR HDMI OUT (not on revision B)	R37, R38, R39, R40, R41, R42, R43, R44	not populated
DIFFERENTIAL PAIR - HDMI OUT (not on revision B)	R47, R48, R49, R50, R51, R52, R53, R54	populated with 0 Ω
PULL UP DIFFERENTIAL PAIR HDMI IN	R1, R2, R3, R4, R6, R7, R8, R9	not populated

2.6.1 HPD Snoop Option – not available prior to Revision B EVM

To accommodate systems that do not properly resend DDC commands after HPD goes low, TI has implemented an HPD snoop mode on the TMDS171RGZ revision B EVM. This mode allows the HPD line to be routed around the TMDS171, but remain connected to the TMDS171 on the sink side to allow the TMDS171 to snoop its state. This snoop mode is disabled by default on the TMDS171RGZ revision B EVMs.

- Pop R131, no pop R129, R130 for HPD on
- No pop R131, pop R129, R130 for HPD snoop only

2.6.2 DDC Snoop Option – not available prior to Revision B EVM

To accommodate systems that do not properly support clock stretching on the DDC lines, TI implemented a snoop mode on the TMDS171RGZ revision B EVM. This mode allows the DDC lines to be routed around the TMDS171, but remain connected to the TMDS171 on the sink side to allow the TMDS171 to snoop the DDC traffic. This snoop mode is enabled by default on the TMDS171RGZ revision B EVMs.

- Pop R16, R17, R24, R25. No pop R123, R124, R125, R126 - TMDS171, DDC on
- No pop R16, R17, R24, R25. Pop R123, R124, R125, R126 - TMDS171, DDC snoop only

2.7 USB Interface via TUSB3410

- Install the Eye Scan software from TI
- J6 must be set to SDA – SDA_USB
- J4 must be set to SCL – SCL_USB
- Attached the USB micro cable to J13 and to the host computer
- Start the Eye Scan software

Figure 4 illustrates the *Eye Scan* opening tab.

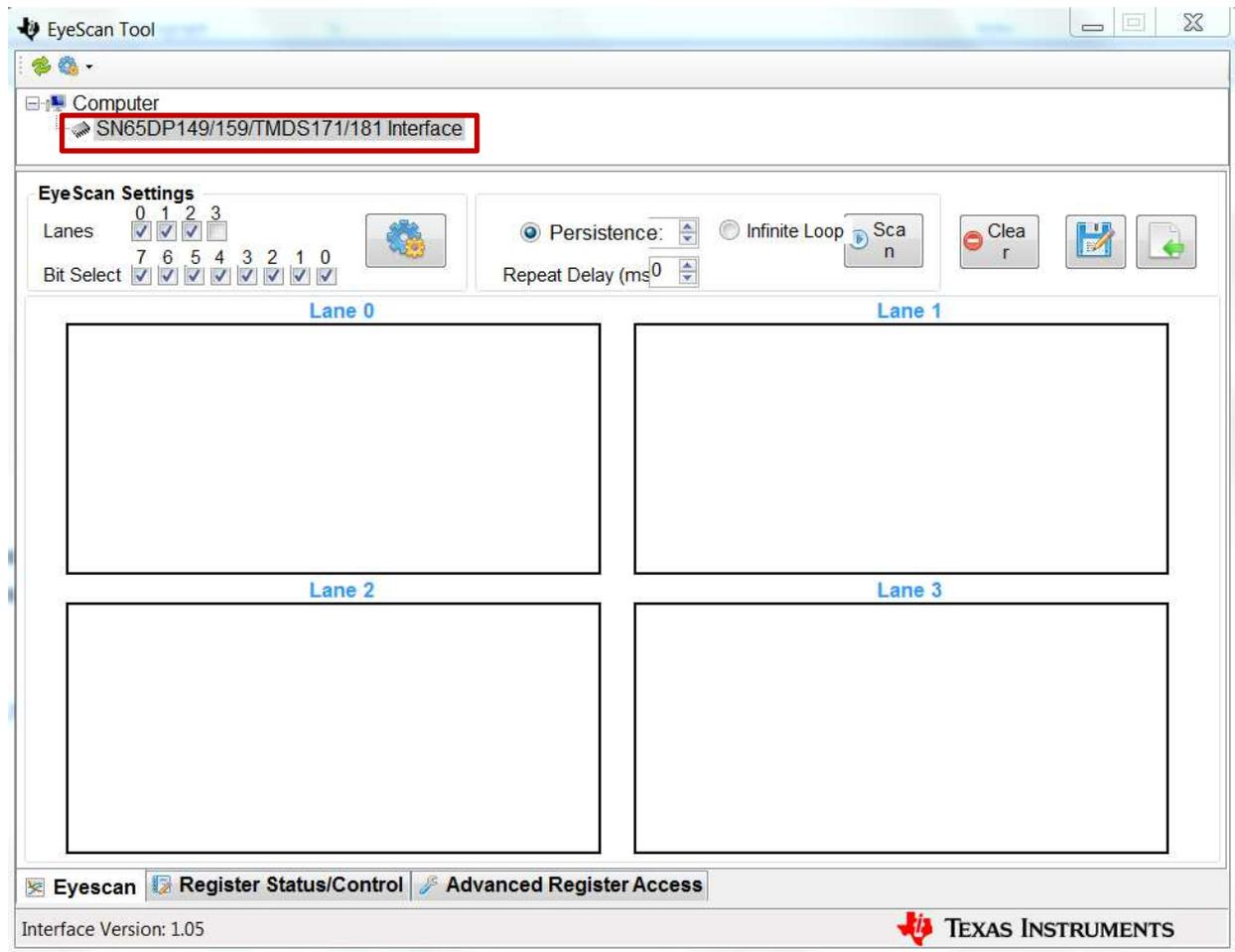

Figure 4. Eye Scan Opening Tab

Confirm that the SN65DP149/159/TMDS171/171 interface is present and selected. If it is not, check the USB connection and confirm that the driver is loaded in *Device Manager*.

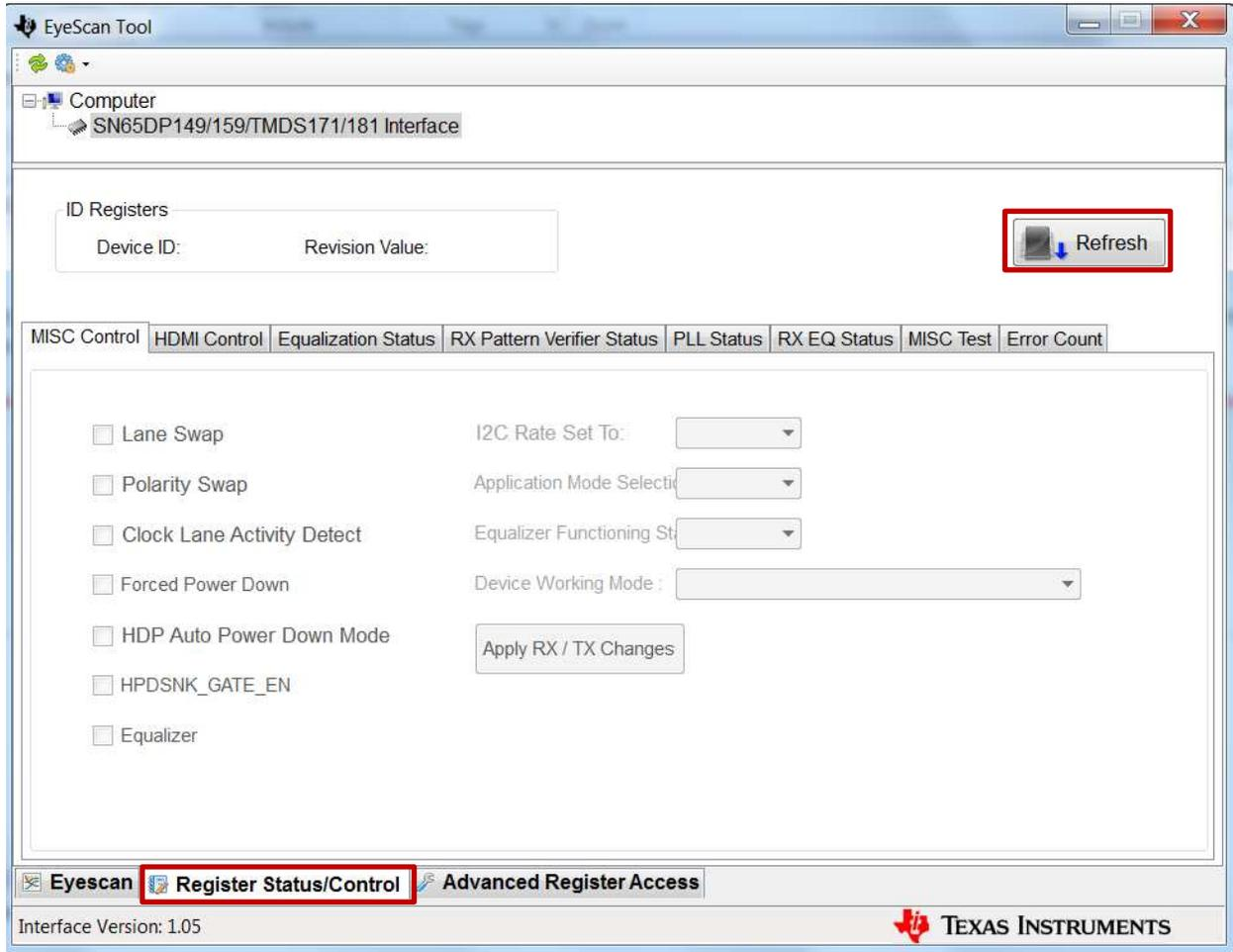

Figure 5. Register Status/Control Tab

Select the *Register Status/Control* tab and click *Refresh*.

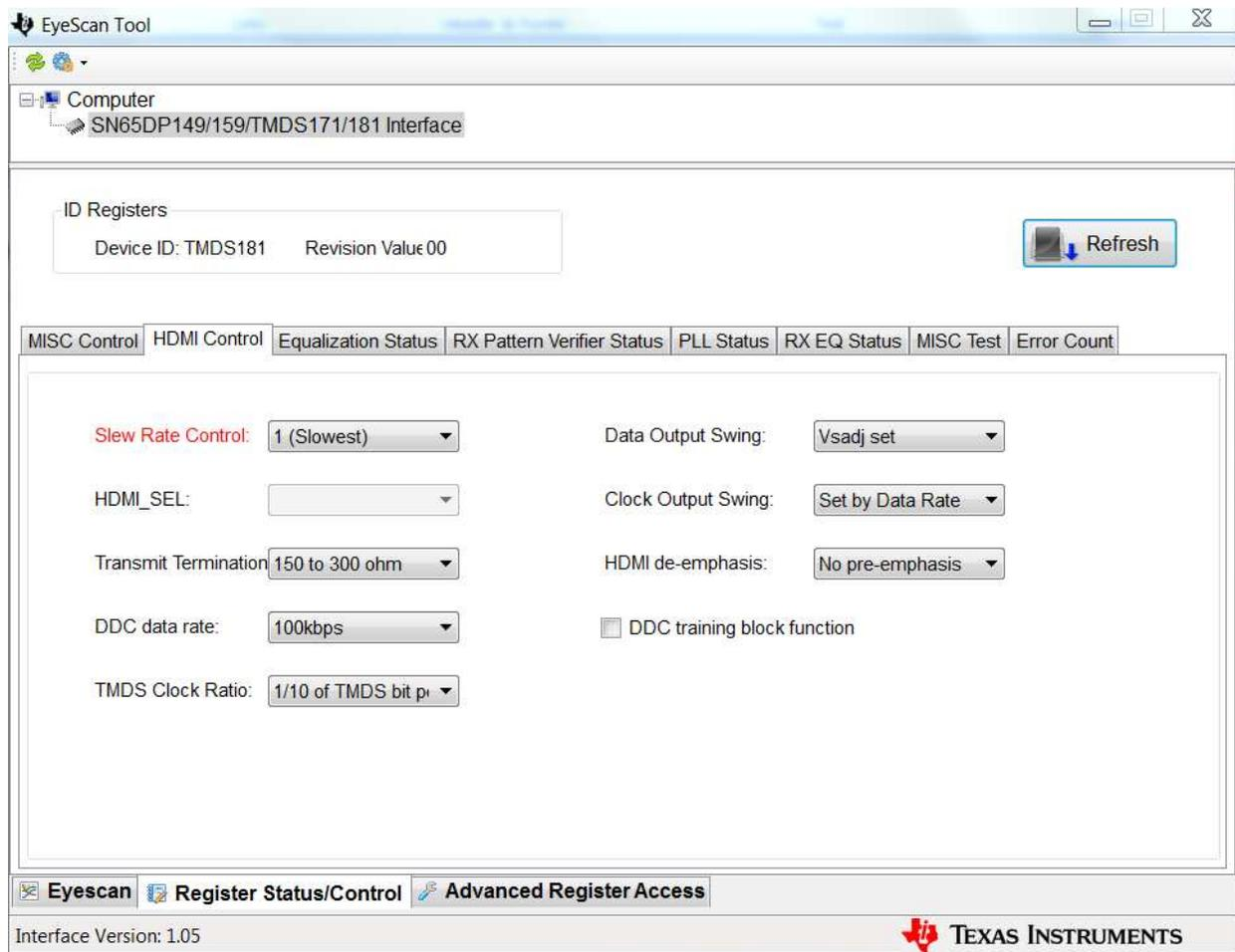

Figure 6. TMDS171 Device with TMDS Clock Ratio set to 1/10

If using a generator or source that does not support DDC clock stretching per the I²C specification, when running at HDMI speeds it may be necessary to force the *TMDS Clock Ratio Bit*. Select the *HDMI Control* tab and check the *DDC clock training block function*, change the *TMDS Clock Ratio*: to 1/40.

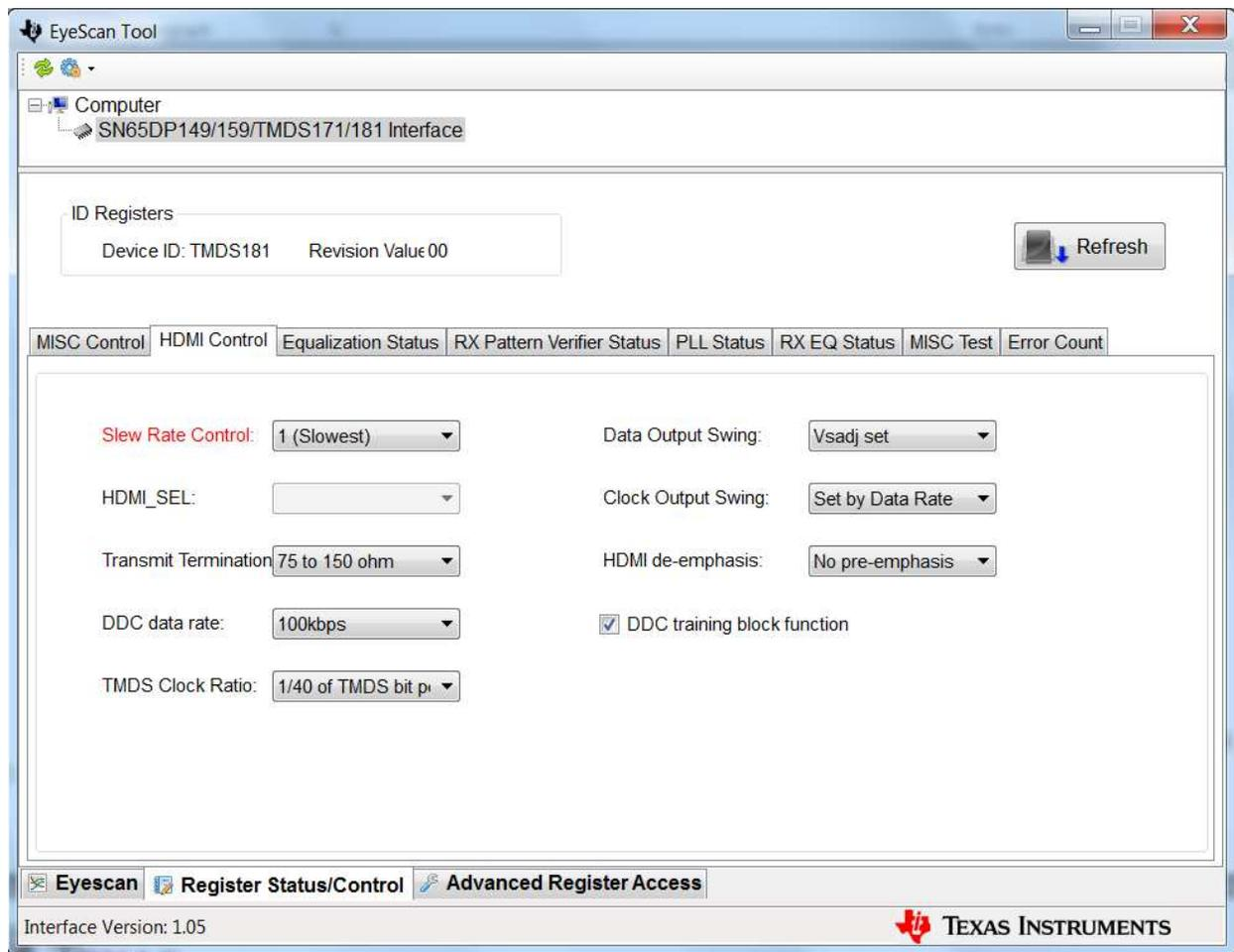

Figure 7. TMDS171 Device with TMDS Clock Ratio set to 1/40

3 Quick Start Guide

1. Apply 5-V power to the EVM, turn on SW2. LED D2 should light up.
2. If using external I²C adapter instead of pin straps, please configure the TMDS171 at this step.
3. Plug in an HDMI source using a standard HDMI cable into P1 (Standard HDMI connector).
4. Plug in an HDMI video sink device into P2 (Standard HDMI connector) using a standard HDMI cable.
5. Video output on HDMI sink should be observed

4 References

1. [TMDS171 Product Preview](#)
2. [Aardvark I2C/SPI Host Adapter User Manual](#)
3. [High-Definition Multimedia Interface Specification Version 1.4b.](#)
4. [High-Definition Multimedia Interface Specification Version 2.0](#)

5 EVM Bill of Materials

Table 4. EVM Bill of Materials

QTY	Reference	Part	PCB Footprint	Manufacturer	Part Number
6	C1, C4, C5, C6, C7, C52	1 μ F	603	Taiyo Yuden	LMK107B7105KA-T
12	C9, C10, C17, C18, C19, C21, C23, C29, C40, C46, C59, C60	0.1 μ F	402	Yageo	CC0402KRX5R6BB104
5	C8, C20, C35, C36, C57	10 μ F	805	TDK	C2012X5R1A106K125AB
1	C31	10 μ F	805	TDK	C2012X5R1C106K085AC
8	C11, C12, C13, C14, C15, C16, C24, C25	0 Ω resistors	201	TDK	C0603X5R0J104M
5	C22, C37, C41, C42, C47	0.01 μ F	402		
1	C26 - DNI	DNI_200 nF	402		
1	C27	18 pF	402	AVX	04025A180JAT2A
1	C28	220 pF	402		
1	C30	220 μ F	7343	Kemet	T495X337K010ATE060
1	C34	3.3 nF	402		
1	C32	22 μ F	805		
2	C39, C58	2.2 μ F	805		
27	R31, R32, R33, R35, R87, R92, R93, R105, R106, R107, R108, R109, R110, R111, R112, R113, R114, R120, C2, C3, C38, R129, R130, R24, R25, R16, R17	DNI	402 / 201		
2	C45, C49	22 pF	402		
2	C50, C51	33 pF	402		
1	D1	Zener 6V	SOT23	Diodes Inc.	MMBZ5233B-FDICT-ND
1	D2	LED Green 0805	805	Lite On	LTST-C171GKT
1	JP1	JUMPER	HDR_THVT_1x2_100		
13	J1, J3, J4, J6, J7, J8, J10, J11, J12, J14, J15, J16, J17	HDR3X1 M 0.1	HDR_THVT_1x3_100	3M	961103-6404-AR
1	J2	Display_Port_Connector_Sink_0	DISPLAYPORT	Molex	47272-0001
1	J5	Header 5x2 0.1" thru-hole	con_thvt_shrd_2x5_100_m	3M	N2510-6002-RB
1	J9	2.1mm x 5.5mm	PJ-202AH	CUI Inc.	PJ-202AH (PJ-002AH)
1	J13	USB Micro B	USB Micro B	FCI	10103592-0001LF
17	LP1, LP2, LP3, LP4, LP5, LP6, LP7, LP8, LP9, LP10, LP11, LP12, LP13, LP14, LP15, LP16, LP17	LP	TESTLOOP	KOBIKONN	151-103-RC
1	L1	2.2 μ H	1008	TDK	VLS252010ET-2R2M
1	L2	1 μ H	1008	TDK	NLCV25T-1R0M-EFR
1	P1	HDMI_IN	CON_HDMI_RT_19_0p50mm	Molex	471510001
1	P2	HDMI_OUT	CON_HDMI_RT_19_0p50mm	Molex	471510001
2	Q1, Q2	FDV301N_NFET_8V	SOT23	Fairchild Semiconductor	FD301N
8	R1, R2, R3, R4, R6, R7, R8, R9 - DNI	DNI	201		
1	R5	100	402		
6	R10, R11, R99, R100, R101, R121	1K	402		
3	R12, R27, R81	100K	402		
1	R13	10	402		
13	R14, R15, R18, R19, R20, R21, R22, R23, R34, R123, R124, R125, R126	0	201		
4	R28, R29, R58, R59	2K	402		
8	R77, R80, R83, R84, R89, R104, R122, R131	0	402		
1	R30	1M	402		
1	R127	500K	402		
1	R36	75	402		
1	R56	27K	402		
16	R57, R60, R61, R62, R63, R64, R65, R66, R67, R68, R69, R70, R71, R72, R73, R74	65K	402		

Table 4. EVM Bill of Materials (continued)

QTY	Reference	Part	PCB Footprint	Manufacturer	Part Number
1	R75	7K	402		
1	R76	PTV09 10K POT	THRUHOLE	BOURNS	PTV09A-4015F-B103
3	R78, R98, R102	10K	402		
2	R79, R88	4.7K	402		
1	R82	500	402		
1	R85	750K	402		
1	R86	240K	402		
1	R90	1.87K	402		
1	R91	4.42K	402		
1	R94	1.5K	402		
2	R95, R96	33	201		
1	R103	15K	402		
3	R45, R46, R115	47K	402		
1	SW1	PB_SWITCH	SW_MOM_2NO	OMRON	B3SN-3012P
1	SW2	3POS_SPDT	THRUHOLE_3POS	NKK Switches	MS13ANW03
1	U1	TMDS171RGZ	48_RGZ	TI	
1	U9	SN74AUP1G04	DCK	TI	SN74AUP1G04DCKR
1	U2 - DNI	SN74CBT1G125 - DNI	DCK	TI	SN74CBT1G125DCKR
1	U3	TPS3808G30DBVT	6DBV	TI	TPS3808G30DBVT
1	U4	TPS62150A	RGT16	TI	TPS62150ARGTT
1	U6 - DNI	TPS61240 - DNI	6DRV	TI	TPS61240DRV
1	U5	TPS74201RGWT	RGW20	TI	TPS74201RGWT
1	U7	TUSB3410	LQFP32	TI	TUSB3410VF
1	U8	24LC256	8SOIC	ON Semiconductor	CAT24C256W
1	Y1	12 MHz Crystal	ECX-32	ECS Inc.	ECS-120-20-33-TR
1	U16	TPD2E001	drl_5pin	TI	TPD2E001

6 EVM Schematics

Figure 8 through Figure 14 illustrate the EVM schematics.

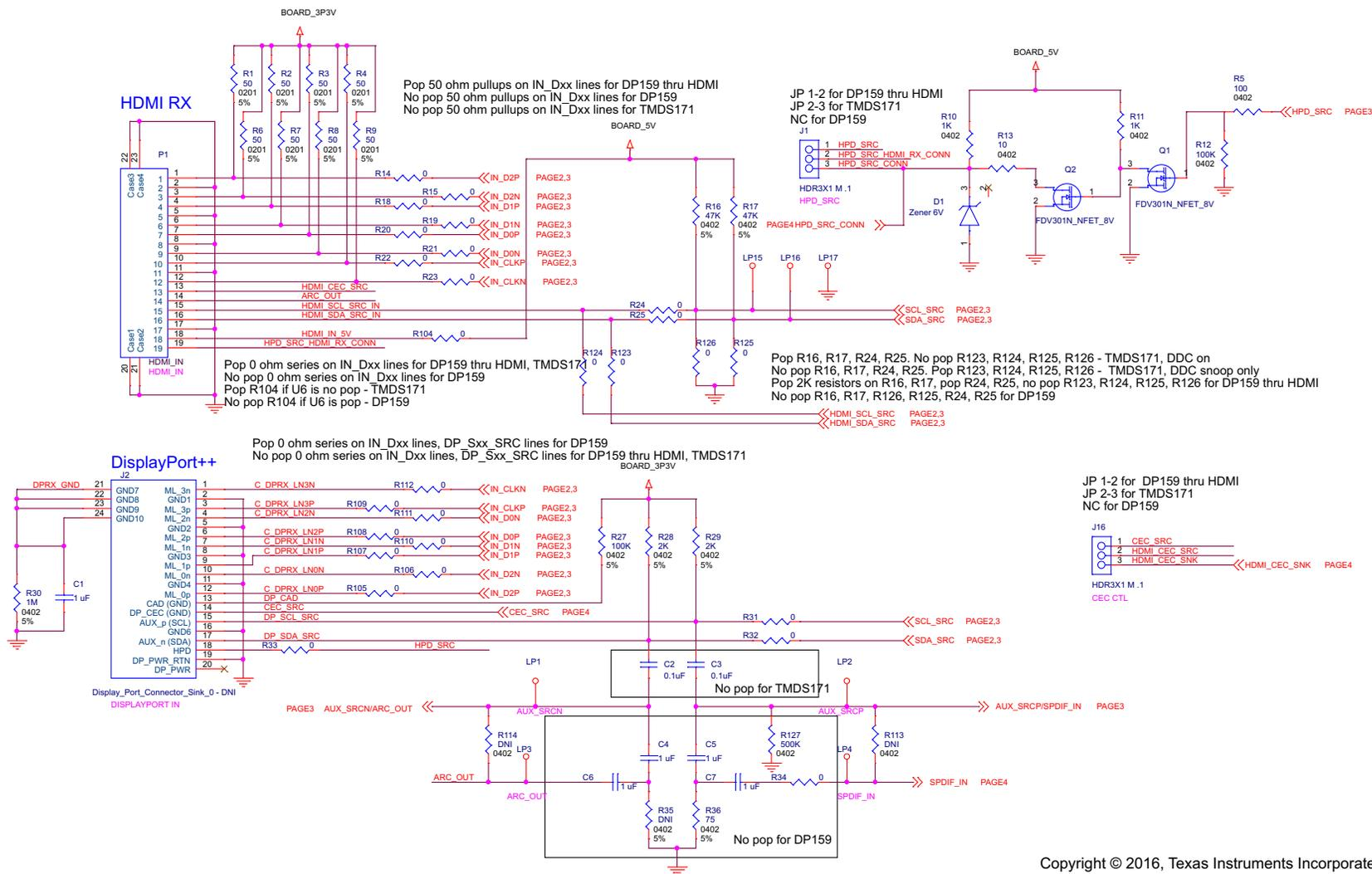

Figure 8. HDMI Input Connector

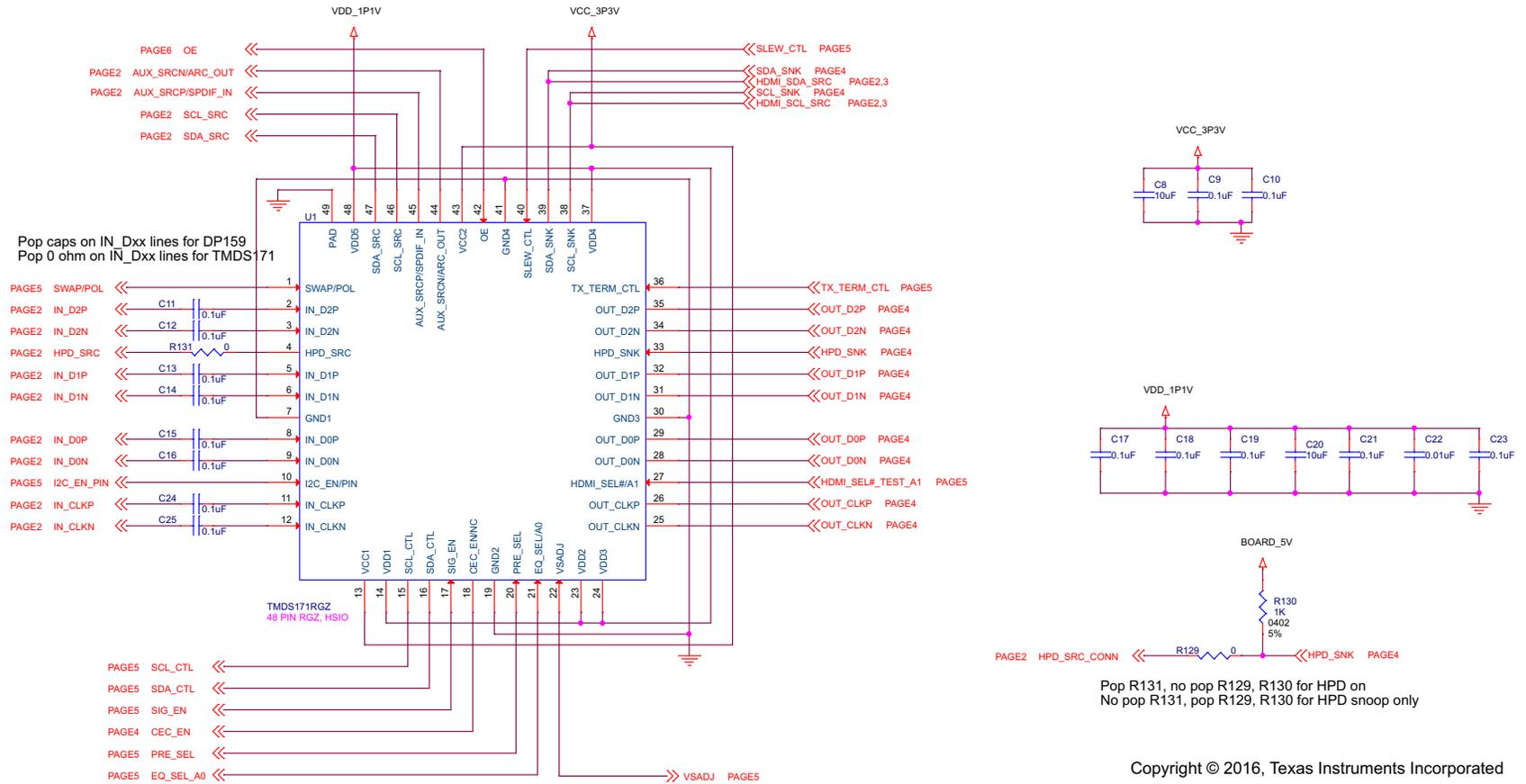
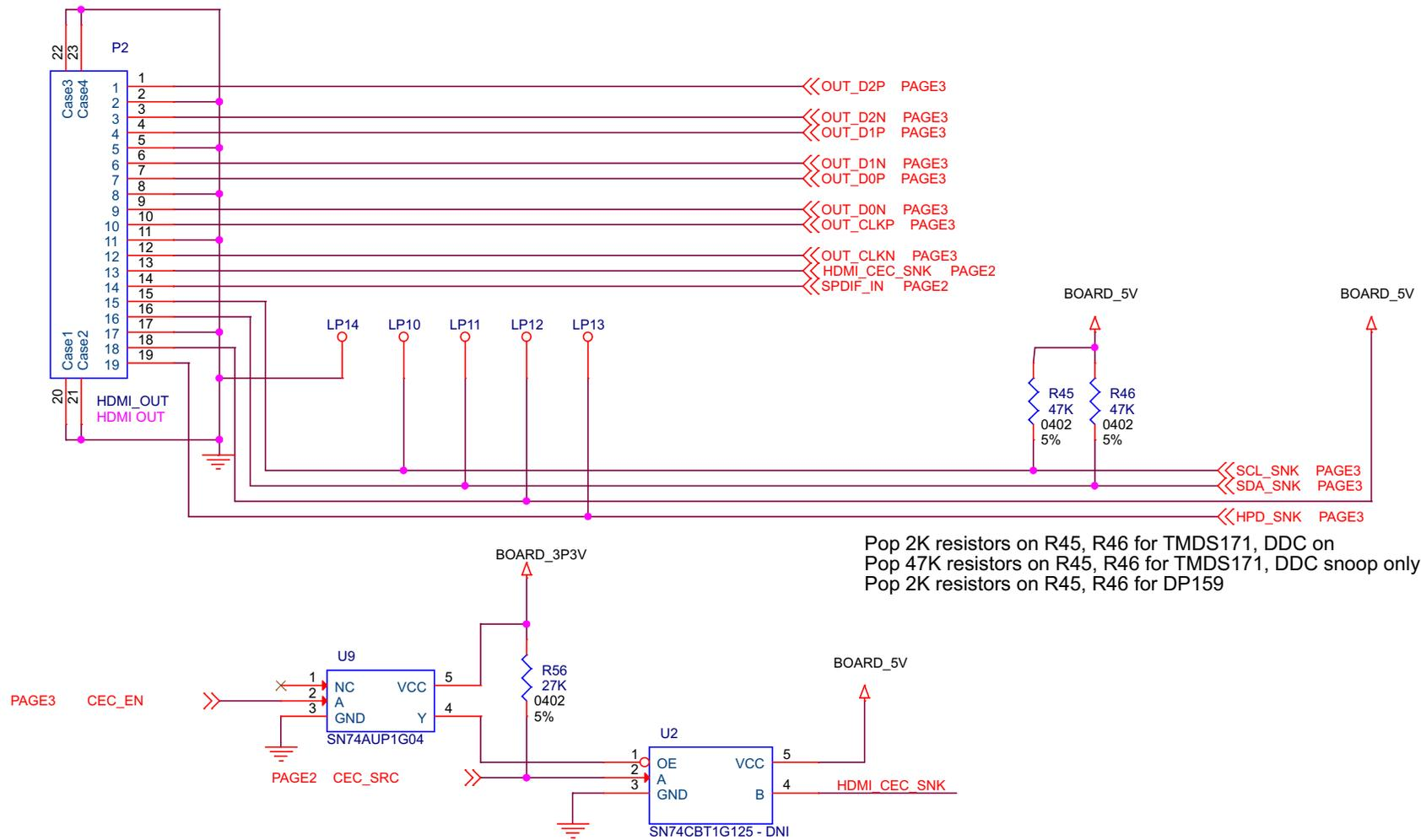

Figure 9. TMS171 RGZ Schematic (48-Pin QFN)

HDMI TX



Pop 2K resistors on R45, R46 for TMDS171, DDC on
 Pop 47K resistors on R45, R46 for TMDS171, DDC snoop only
 Pop 2K resistors on R45, R46 for DP159

Pop U2 DP159 thru HDMI, DP159
 No pop U2 for TMDS171

Copyright © 2016, Texas Instruments Incorporated

Figure 10. HDMI TX Connector

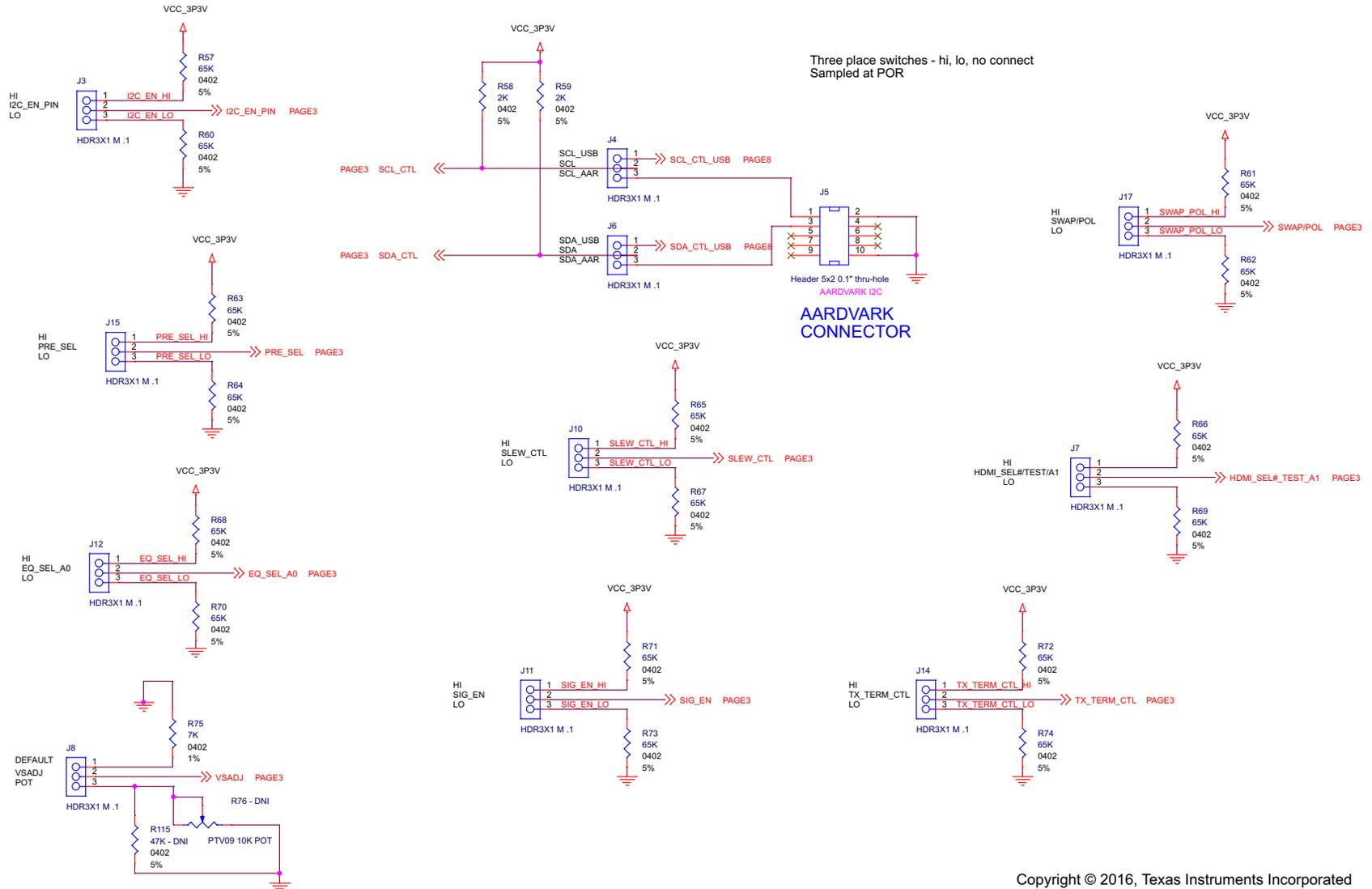
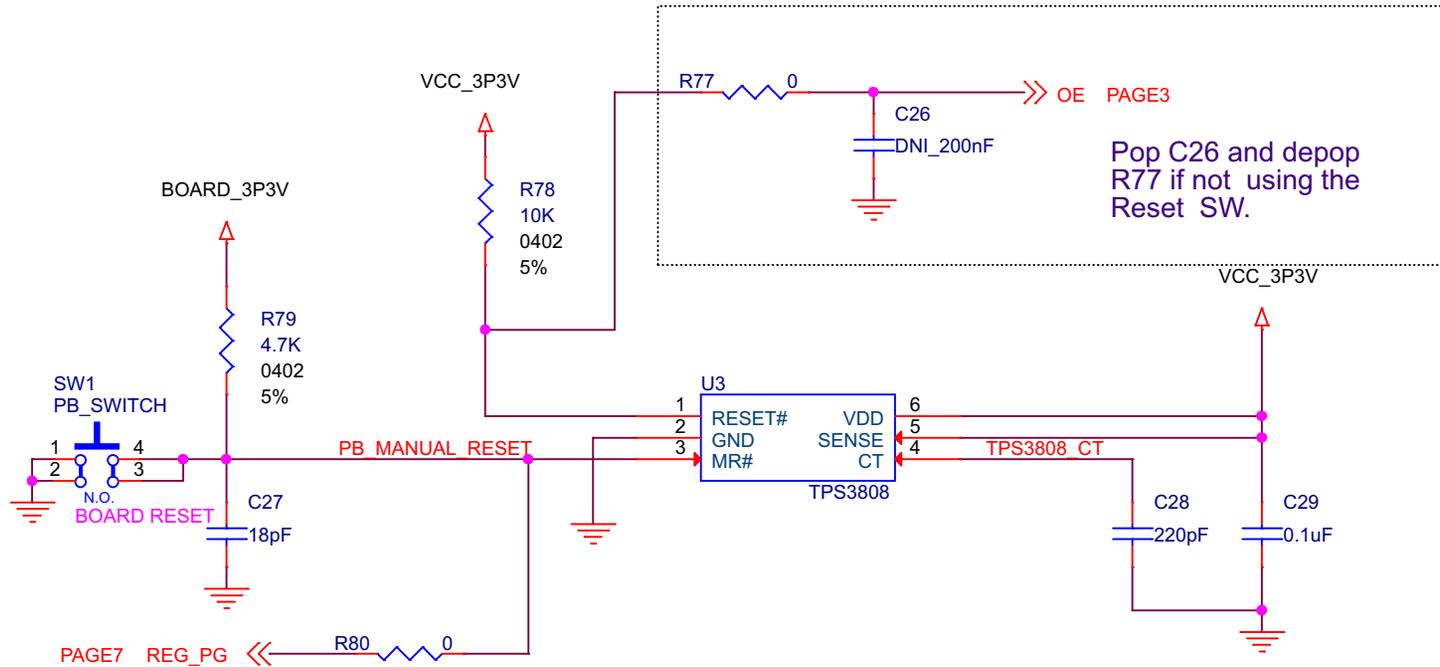

Figure 11. TMS171 Select Options

RESET CIRCUIT



Copyright © 2016, Texas Instruments Incorporated

Figure 12. RESET Circuit

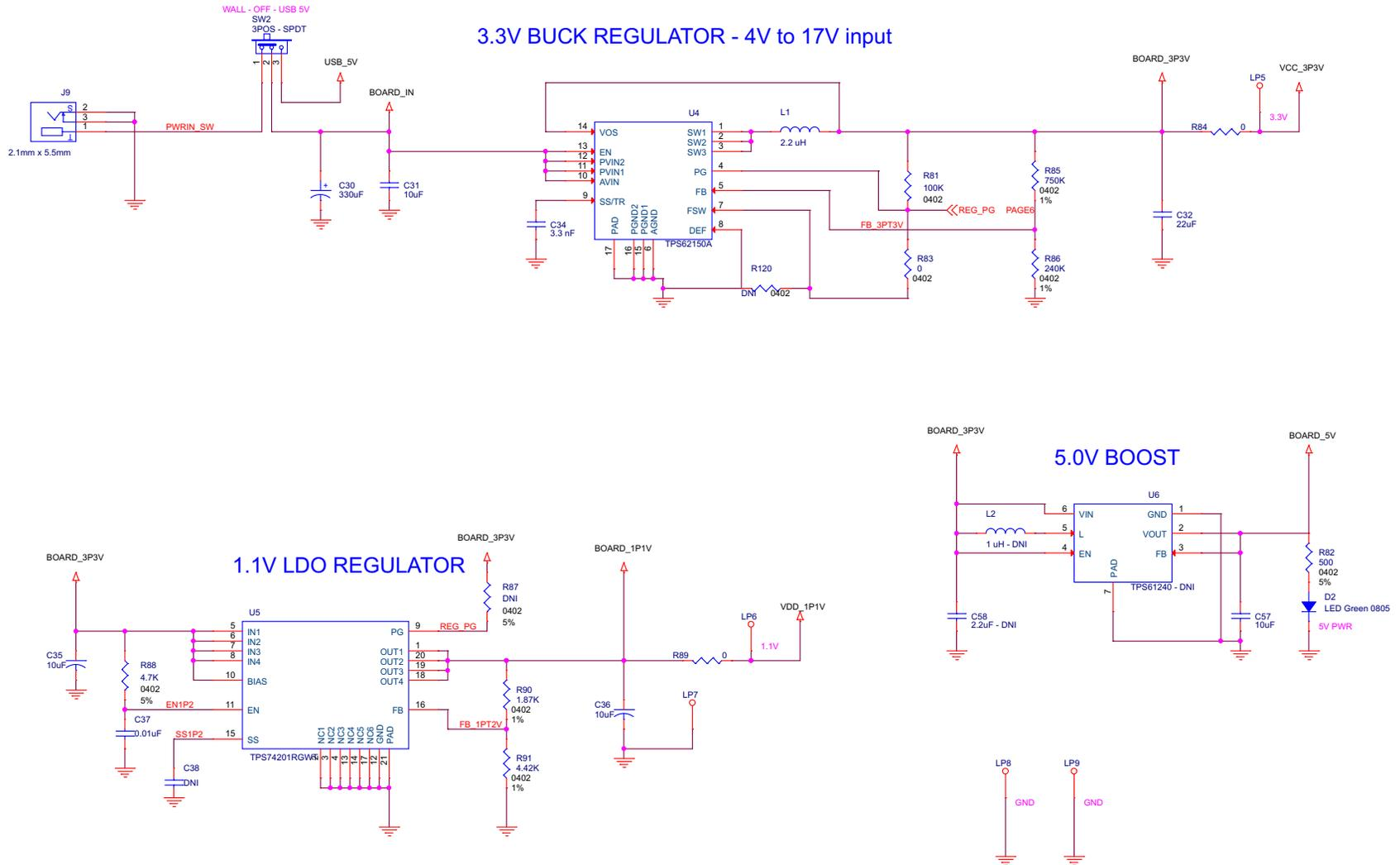

Copyright © 2016, Texas Instruments Incorporated

Figure 13. Power Schematics (1.1-V and 3.3-V Regulators)

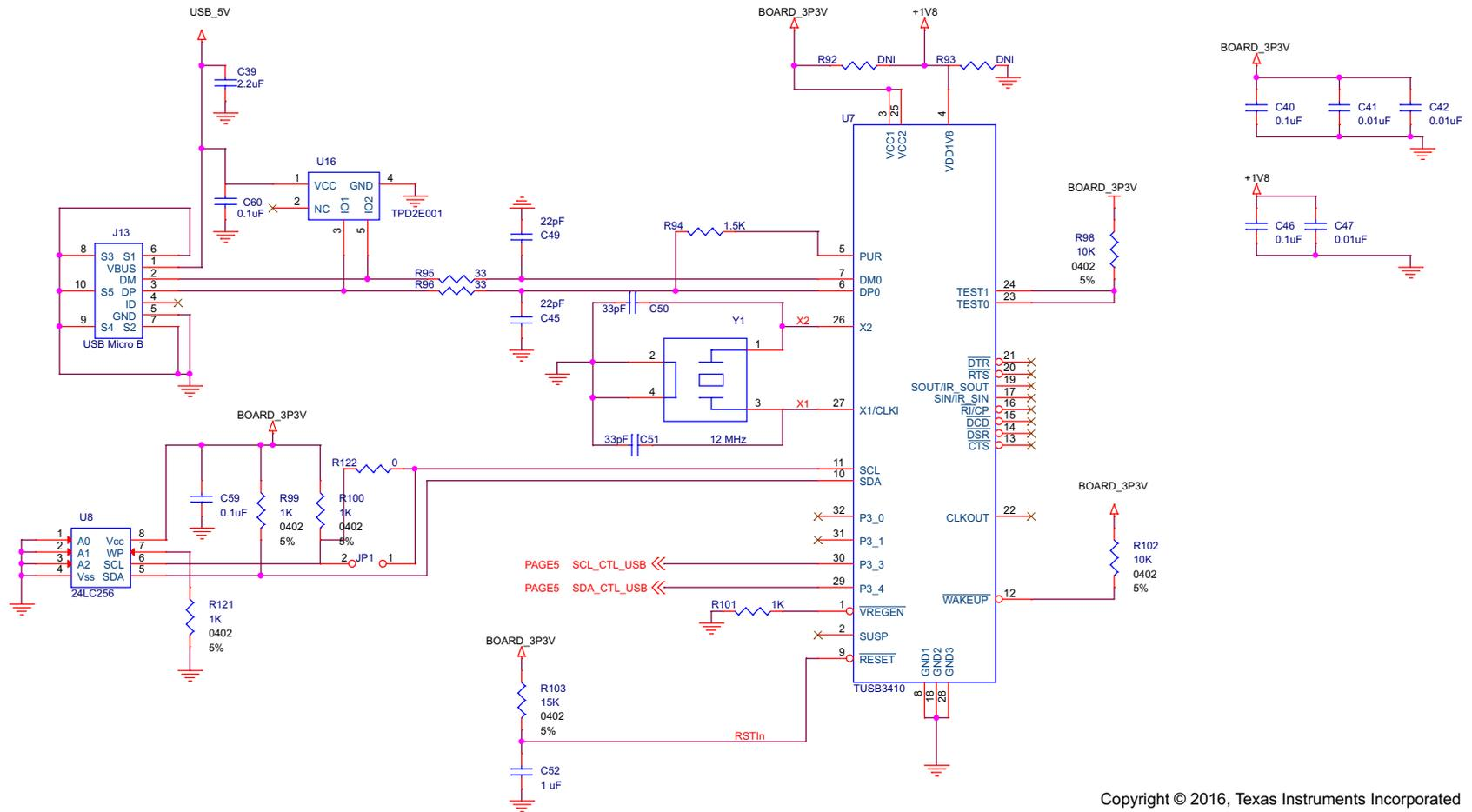

Copyright © 2016, Texas Instruments Incorporated

Figure 14. TUSB3410 Schematic

7 EVM Layout

Figure 15 through Figure 20 illustrate the PCB layout images for the EVM.

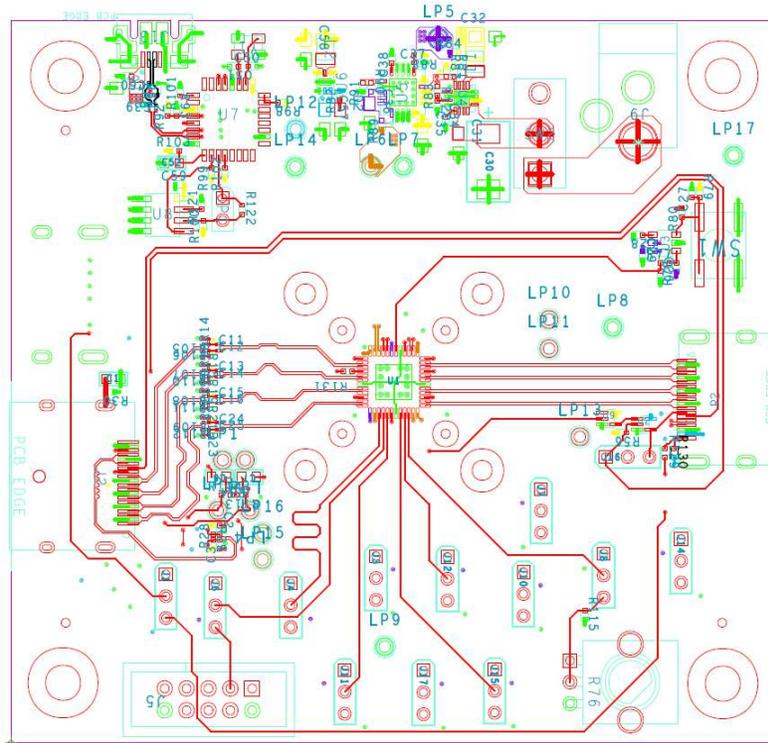

Figure 15. Layer 1 (Top)

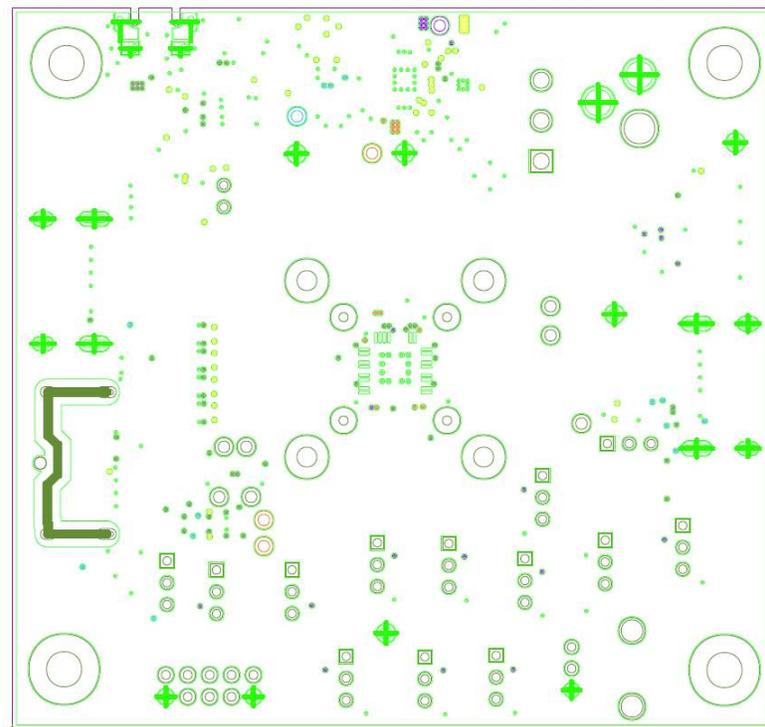

Figure 16. Layer 2 (GND)

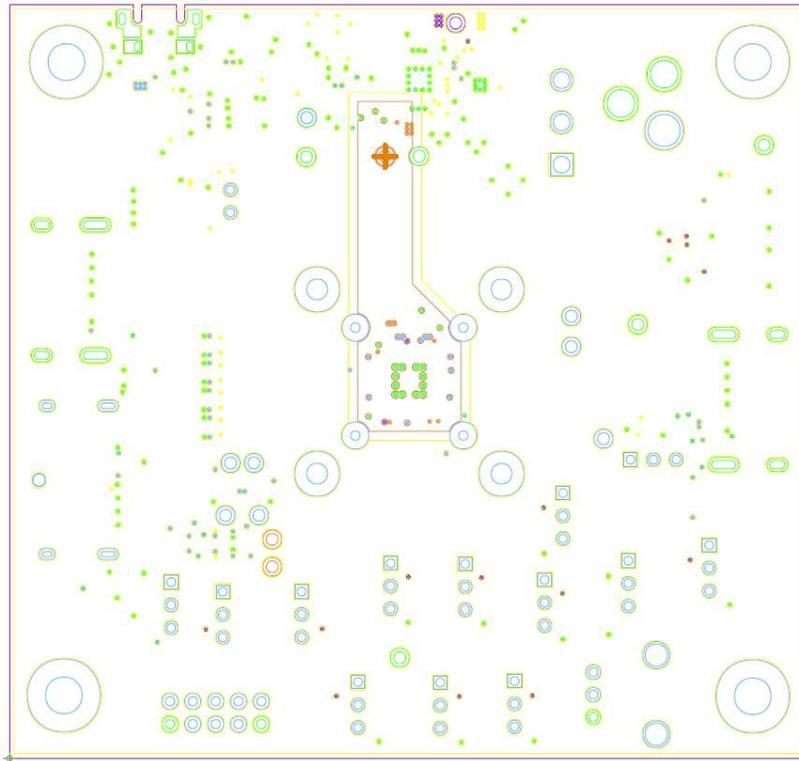

Figure 17. Layer 3 (Power)

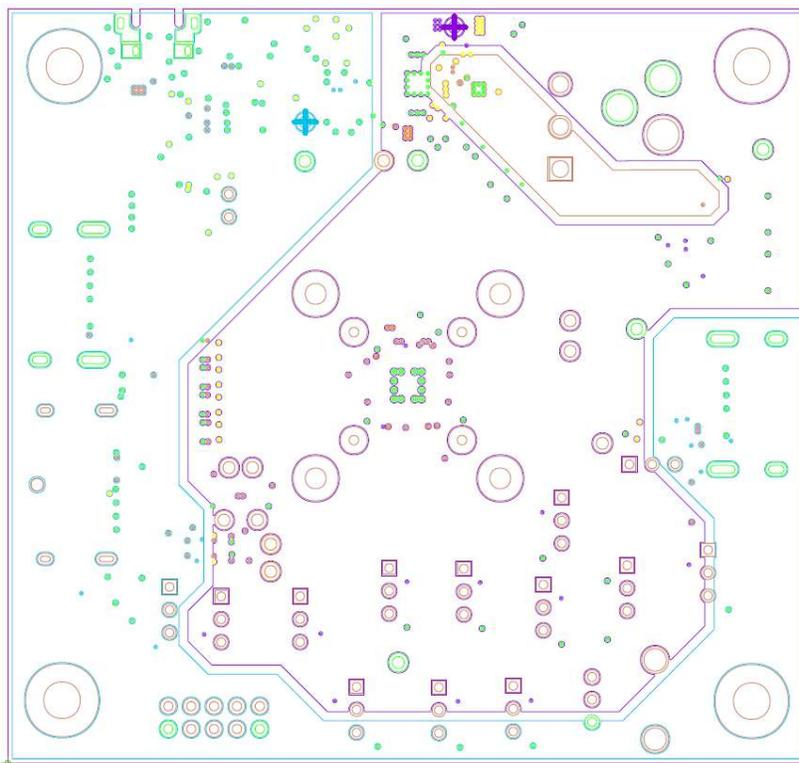

Figure 18. Layer 4 (Power)

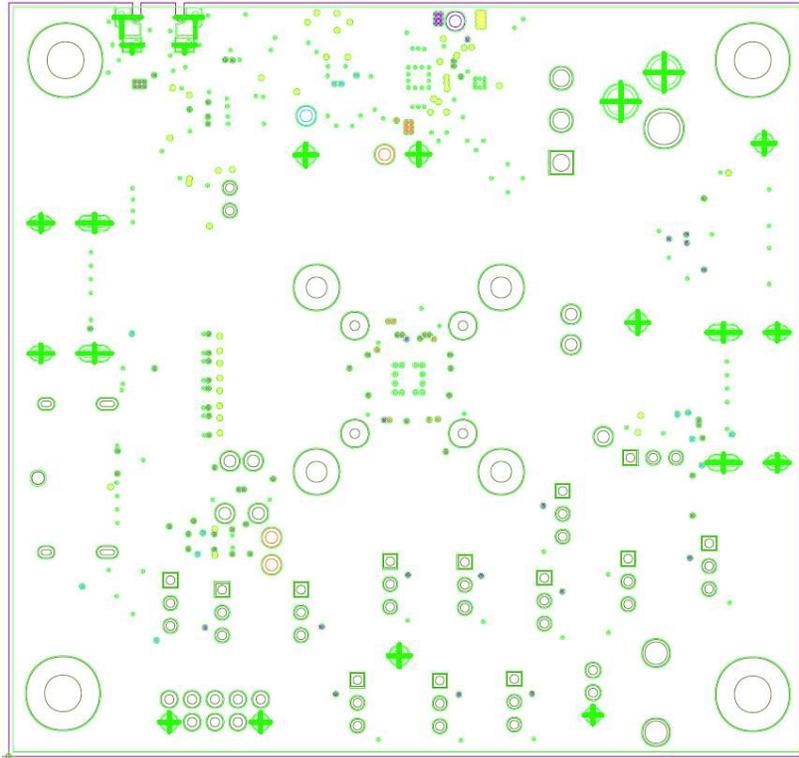

Figure 19. Layer 5 (GND)

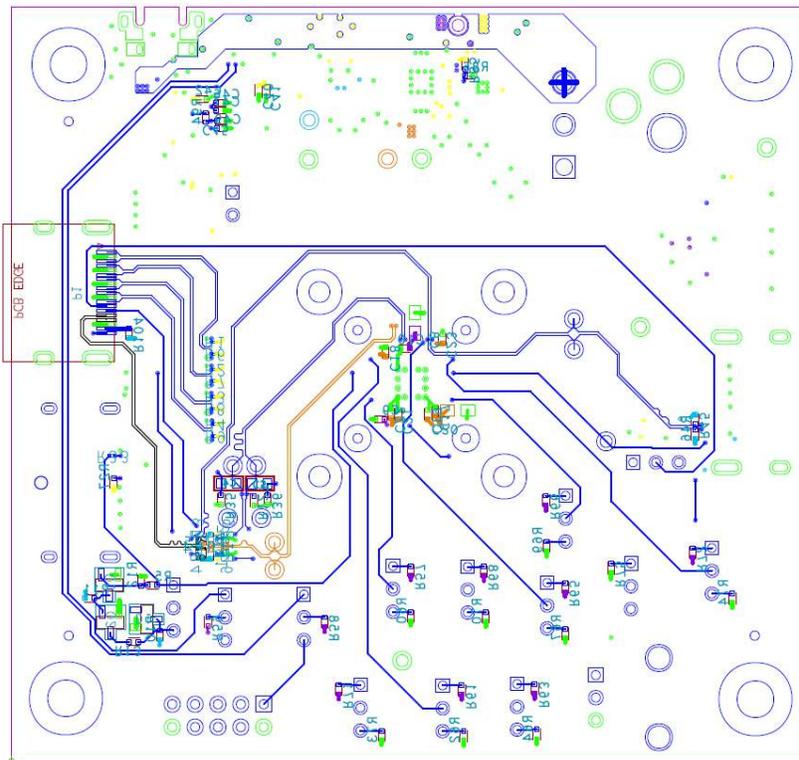

Figure 20. Layer 6 (Bottom)

8 Total Phase Aardvark I2C Host Adapter Scripts

Request the latest scripts from your TI representative.

Revision History

NOTE: Page numbers for previous revisions may differ from page numbers in the current version.

Changes from Original (April, 2015) to A Revision	Page
• Changed signal rate to 6Gbps and resolutions support to 4k/2k/60p in the <i>What is the TMDS171?</i> section.....	2
• Changed and added text, added <i>TMDS171 Device with TMDS Clock Ratio set to 1/40</i> image and changed all other GUI images in the <i>USB Interface via TUSB3410</i> section.....	8

STANDARD TERMS AND CONDITIONS FOR EVALUATION MODULES

1. *Delivery:* TI delivers TI evaluation boards, kits, or modules, including any accompanying demonstration software, components, or documentation (collectively, an "EVM" or "EVMs") to the User ("User") in accordance with the terms and conditions set forth herein. Acceptance of the EVM is expressly subject to the following terms and conditions.
 - 1.1 EVMs are intended solely for product or software developers for use in a research and development setting to facilitate feasibility evaluation, experimentation, or scientific analysis of TI semiconductors products. EVMs have no direct function and are not finished products. EVMs shall not be directly or indirectly assembled as a part or subassembly in any finished product. For clarification, any software or software tools provided with the EVM ("Software") shall not be subject to the terms and conditions set forth herein but rather shall be subject to the applicable terms and conditions that accompany such Software
 - 1.2 EVMs are not intended for consumer or household use. EVMs may not be sold, sublicensed, leased, rented, loaned, assigned, or otherwise distributed for commercial purposes by Users, in whole or in part, or used in any finished product or production system.
2. *Limited Warranty and Related Remedies/Disclaimers:*
 - 2.1 These terms and conditions do not apply to Software. The warranty, if any, for Software is covered in the applicable Software License Agreement.
 - 2.2 TI warrants that the TI EVM will conform to TI's published specifications for ninety (90) days after the date TI delivers such EVM to User. Notwithstanding the foregoing, TI shall not be liable for any defects that are caused by neglect, misuse or mistreatment by an entity other than TI, including improper installation or testing, or for any EVMs that have been altered or modified in any way by an entity other than TI. Moreover, TI shall not be liable for any defects that result from User's design, specifications or instructions for such EVMs. Testing and other quality control techniques are used to the extent TI deems necessary or as mandated by government requirements. TI does not test all parameters of each EVM.
 - 2.3 If any EVM fails to conform to the warranty set forth above, TI's sole liability shall be at its option to repair or replace such EVM, or credit User's account for such EVM. TI's liability under this warranty shall be limited to EVMs that are returned during the warranty period to the address designated by TI and that are determined by TI not to conform to such warranty. If TI elects to repair or replace such EVM, TI shall have a reasonable time to repair such EVM or provide replacements. Repaired EVMs shall be warranted for the remainder of the original warranty period. Replaced EVMs shall be warranted for a new full ninety (90) day warranty period.
3. *Regulatory Notices:*
 - 3.1 *United States*
 - 3.1.1 *Notice applicable to EVMs not FCC-Approved:*

This kit is designed to allow product developers to evaluate electronic components, circuitry, or software associated with the kit to determine whether to incorporate such items in a finished product and software developers to write software applications for use with the end product. This kit is not a finished product and when assembled may not be resold or otherwise marketed unless all required FCC equipment authorizations are first obtained. Operation is subject to the condition that this product not cause harmful interference to licensed radio stations and that this product accept harmful interference. Unless the assembled kit is designed to operate under part 15, part 18 or part 95 of this chapter, the operator of the kit must operate under the authority of an FCC license holder or must secure an experimental authorization under part 5 of this chapter.
 - 3.1.2 *For EVMs annotated as FCC – FEDERAL COMMUNICATIONS COMMISSION Part 15 Compliant:*

CAUTION

This device complies with part 15 of the FCC Rules. Operation is subject to the following two conditions: (1) This device may not cause harmful interference, and (2) this device must accept any interference received, including interference that may cause undesired operation.

Changes or modifications not expressly approved by the party responsible for compliance could void the user's authority to operate the equipment.

FCC Interference Statement for Class A EVM devices

NOTE: This equipment has been tested and found to comply with the limits for a Class A digital device, pursuant to part 15 of the FCC Rules. These limits are designed to provide reasonable protection against harmful interference when the equipment is operated in a commercial environment. This equipment generates, uses, and can radiate radio frequency energy and, if not installed and used in accordance with the instruction manual, may cause harmful interference to radio communications. Operation of this equipment in a residential area is likely to cause harmful interference in which case the user will be required to correct the interference at his own expense.

FCC Interference Statement for Class B EVM devices

NOTE: This equipment has been tested and found to comply with the limits for a Class B digital device, pursuant to part 15 of the FCC Rules. These limits are designed to provide reasonable protection against harmful interference in a residential installation. This equipment generates, uses and can radiate radio frequency energy and, if not installed and used in accordance with the instructions, may cause harmful interference to radio communications. However, there is no guarantee that interference will not occur in a particular installation. If this equipment does cause harmful interference to radio or television reception, which can be determined by turning the equipment off and on, the user is encouraged to try to correct the interference by one or more of the following measures:

- Reorient or relocate the receiving antenna.
- Increase the separation between the equipment and receiver.
- Connect the equipment into an outlet on a circuit different from that to which the receiver is connected.
- Consult the dealer or an experienced radio/TV technician for help.

3.2 Canada

3.2.1 For EVMs issued with an Industry Canada Certificate of Conformance to RSS-210

Concerning EVMs Including Radio Transmitters:

This device complies with Industry Canada license-exempt RSS standard(s). Operation is subject to the following two conditions: (1) this device may not cause interference, and (2) this device must accept any interference, including interference that may cause undesired operation of the device.

Concernant les EVMs avec appareils radio:

Le présent appareil est conforme aux CNR d'Industrie Canada applicables aux appareils radio exempts de licence. L'exploitation est autorisée aux deux conditions suivantes: (1) l'appareil ne doit pas produire de brouillage, et (2) l'utilisateur de l'appareil doit accepter tout brouillage radioélectrique subi, même si le brouillage est susceptible d'en compromettre le fonctionnement.

Concerning EVMs Including Detachable Antennas:

Under Industry Canada regulations, this radio transmitter may only operate using an antenna of a type and maximum (or lesser) gain approved for the transmitter by Industry Canada. To reduce potential radio interference to other users, the antenna type and its gain should be so chosen that the equivalent isotropically radiated power (e.i.r.p.) is not more than that necessary for successful communication. This radio transmitter has been approved by Industry Canada to operate with the antenna types listed in the user guide with the maximum permissible gain and required antenna impedance for each antenna type indicated. Antenna types not included in this list, having a gain greater than the maximum gain indicated for that type, are strictly prohibited for use with this device.

Concernant les EVMs avec antennes détachables

Conformément à la réglementation d'Industrie Canada, le présent émetteur radio peut fonctionner avec une antenne d'un type et d'un gain maximal (ou inférieur) approuvé pour l'émetteur par Industrie Canada. Dans le but de réduire les risques de brouillage radioélectrique à l'intention des autres utilisateurs, il faut choisir le type d'antenne et son gain de sorte que la puissance isotrope rayonnée équivalente (p.i.r.e.) ne dépasse pas l'intensité nécessaire à l'établissement d'une communication satisfaisante. Le présent émetteur radio a été approuvé par Industrie Canada pour fonctionner avec les types d'antenne énumérés dans le manuel d'usage et ayant un gain admissible maximal et l'impédance requise pour chaque type d'antenne. Les types d'antenne non inclus dans cette liste, ou dont le gain est supérieur au gain maximal indiqué, sont strictement interdits pour l'exploitation de l'émetteur.

3.3 Japan

3.3.1 *Notice for EVMs delivered in Japan:* Please see http://www.tij.co.jp/lstds/ti_ja/general/eStore/notice_01.page 日本国内に輸入される評価用キット、ボードについては、次のところをご覧ください。
http://www.tij.co.jp/lstds/ti_ja/general/eStore/notice_01.page

3.3.2 *Notice for Users of EVMs Considered "Radio Frequency Products" in Japan:* EVMs entering Japan may not be certified by TI as conforming to Technical Regulations of Radio Law of Japan.

If User uses EVMs in Japan, not certified to Technical Regulations of Radio Law of Japan, User is required by Radio Law of Japan to follow the instructions below with respect to EVMs:

1. Use EVMs in a shielded room or any other test facility as defined in the notification #173 issued by Ministry of Internal Affairs and Communications on March 28, 2006, based on Sub-section 1.1 of Article 6 of the Ministry's Rule for Enforcement of Radio Law of Japan,
2. Use EVMs only after User obtains the license of Test Radio Station as provided in Radio Law of Japan with respect to EVMs, or
3. Use of EVMs only after User obtains the Technical Regulations Conformity Certification as provided in Radio Law of Japan with respect to EVMs. Also, do not transfer EVMs, unless User gives the same notice above to the transferee. Please note that if User does not follow the instructions above, User will be subject to penalties of Radio Law of Japan.

【無線電波を送信する製品の開発キットをお使いになる際の注意事項】 開発キットの中には技術基準適合証明を受けていないものがあります。技術適合証明を受けていないもののご使用に際しては、電波法遵守のため、以下のいずれかの措置を取っていただく必要がありますのでご注意ください。

1. 電波法施行規則第6条第1項第1号に基づく平成18年3月28日総務省告示第173号で定められた電波暗室等の試験設備でご使用いただく。
2. 実験局の免許を取得後ご使用いただく。
3. 技術基準適合証明を取得後ご使用いただく。

なお、本製品は、上記の「ご使用にあたっての注意」を譲渡先、移転先に通知しない限り、譲渡、移転できないものとします。

上記を遵守頂けない場合は、電波法の罰則が適用される可能性があることをご留意ください。日本テキサス・インスツルメンツ株式会社
東京都新宿区西新宿 6 丁目 2 4 番 1 号
西新宿三井ビル

3.3.3 *Notice for EVMs for Power Line Communication:* Please see http://www.tij.co.jp/llds/ti_ja/general/eStore/notice_02.page
電力線搬送波通信についての開発キットをお使いになる際の注意事項については、次のところをご覧ください。http://www.tij.co.jp/llds/ti_ja/general/eStore/notice_02.page

4 *EVM Use Restrictions and Warnings:*

4.1 EVMS ARE NOT FOR USE IN FUNCTIONAL SAFETY AND/OR SAFETY CRITICAL EVALUATIONS, INCLUDING BUT NOT LIMITED TO EVALUATIONS OF LIFE SUPPORT APPLICATIONS.

4.2 User must read and apply the user guide and other available documentation provided by TI regarding the EVM prior to handling or using the EVM, including without limitation any warning or restriction notices. The notices contain important safety information related to, for example, temperatures and voltages.

4.3 *Safety-Related Warnings and Restrictions:*

4.3.1 User shall operate the EVM within TI's recommended specifications and environmental considerations stated in the user guide, other available documentation provided by TI, and any other applicable requirements and employ reasonable and customary safeguards. Exceeding the specified performance ratings and specifications (including but not limited to input and output voltage, current, power, and environmental ranges) for the EVM may cause personal injury or death, or property damage. If there are questions concerning performance ratings and specifications, User should contact a TI field representative prior to connecting interface electronics including input power and intended loads. Any loads applied outside of the specified output range may also result in unintended and/or inaccurate operation and/or possible permanent damage to the EVM and/or interface electronics. Please consult the EVM user guide prior to connecting any load to the EVM output. If there is uncertainty as to the load specification, please contact a TI field representative. During normal operation, even with the inputs and outputs kept within the specified allowable ranges, some circuit components may have elevated case temperatures. These components include but are not limited to linear regulators, switching transistors, pass transistors, current sense resistors, and heat sinks, which can be identified using the information in the associated documentation. When working with the EVM, please be aware that the EVM may become very warm.

4.3.2 EVMs are intended solely for use by technically qualified, professional electronics experts who are familiar with the dangers and application risks associated with handling electrical mechanical components, systems, and subsystems. User assumes all responsibility and liability for proper and safe handling and use of the EVM by User or its employees, affiliates, contractors or designees. User assumes all responsibility and liability to ensure that any interfaces (electronic and/or mechanical) between the EVM and any human body are designed with suitable isolation and means to safely limit accessible leakage currents to minimize the risk of electrical shock hazard. User assumes all responsibility and liability for any improper or unsafe handling or use of the EVM by User or its employees, affiliates, contractors or designees.

4.4 User assumes all responsibility and liability to determine whether the EVM is subject to any applicable international, federal, state, or local laws and regulations related to User's handling and use of the EVM and, if applicable, User assumes all responsibility and liability for compliance in all respects with such laws and regulations. User assumes all responsibility and liability for proper disposal and recycling of the EVM consistent with all applicable international, federal, state, and local requirements.

5. *Accuracy of Information:* To the extent TI provides information on the availability and function of EVMs, TI attempts to be as accurate as possible. However, TI does not warrant the accuracy of EVM descriptions, EVM availability or other information on its websites as accurate, complete, reliable, current, or error-free.

6. *Disclaimers:*
- 6.1 EXCEPT AS SET FORTH ABOVE, EVMS AND ANY WRITTEN DESIGN MATERIALS PROVIDED WITH THE EVM (AND THE DESIGN OF THE EVM ITSELF) ARE PROVIDED "AS IS" AND "WITH ALL FAULTS." TI DISCLAIMS ALL OTHER WARRANTIES, EXPRESS OR IMPLIED, REGARDING SUCH ITEMS, INCLUDING BUT NOT LIMITED TO ANY IMPLIED WARRANTIES OF MERCHANTABILITY OR FITNESS FOR A PARTICULAR PURPOSE OR NON-INFRINGEMENT OF ANY THIRD PARTY PATENTS, COPYRIGHTS, TRADE SECRETS OR OTHER INTELLECTUAL PROPERTY RIGHTS.
- 6.2 EXCEPT FOR THE LIMITED RIGHT TO USE THE EVM SET FORTH HEREIN, NOTHING IN THESE TERMS AND CONDITIONS SHALL BE CONSTRUED AS GRANTING OR CONFERRING ANY RIGHTS BY LICENSE, PATENT, OR ANY OTHER INDUSTRIAL OR INTELLECTUAL PROPERTY RIGHT OF TI, ITS SUPPLIERS/LICENSORS OR ANY OTHER THIRD PARTY, TO USE THE EVM IN ANY FINISHED END-USER OR READY-TO-USE FINAL PRODUCT, OR FOR ANY INVENTION, DISCOVERY OR IMPROVEMENT MADE, CONCEIVED OR ACQUIRED PRIOR TO OR AFTER DELIVERY OF THE EVM.
7. *USER'S INDEMNITY OBLIGATIONS AND REPRESENTATIONS.* USER WILL DEFEND, INDEMNIFY AND HOLD TI, ITS LICENSORS AND THEIR REPRESENTATIVES HARMLESS FROM AND AGAINST ANY AND ALL CLAIMS, DAMAGES, LOSSES, EXPENSES, COSTS AND LIABILITIES (COLLECTIVELY, "CLAIMS") ARISING OUT OF OR IN CONNECTION WITH ANY HANDLING OR USE OF THE EVM THAT IS NOT IN ACCORDANCE WITH THESE TERMS AND CONDITIONS. THIS OBLIGATION SHALL APPLY WHETHER CLAIMS ARISE UNDER STATUTE, REGULATION, OR THE LAW OF TORT, CONTRACT OR ANY OTHER LEGAL THEORY, AND EVEN IF THE EVM FAILS TO PERFORM AS DESCRIBED OR EXPECTED.
8. *Limitations on Damages and Liability:*
- 8.1 *General Limitations.* IN NO EVENT SHALL TI BE LIABLE FOR ANY SPECIAL, COLLATERAL, INDIRECT, PUNITIVE, INCIDENTAL, CONSEQUENTIAL, OR EXEMPLARY DAMAGES IN CONNECTION WITH OR ARISING OUT OF THESE TERMS AND CONDITIONS OR THE USE OF THE EVMS PROVIDED HEREUNDER, REGARDLESS OF WHETHER TI HAS BEEN ADVISED OF THE POSSIBILITY OF SUCH DAMAGES. EXCLUDED DAMAGES INCLUDE, BUT ARE NOT LIMITED TO, COST OF REMOVAL OR REINSTALLATION, ANCILLARY COSTS TO THE PROCUREMENT OF SUBSTITUTE GOODS OR SERVICES, RETESTING, OUTSIDE COMPUTER TIME, LABOR COSTS, LOSS OF GOODWILL, LOSS OF PROFITS, LOSS OF SAVINGS, LOSS OF USE, LOSS OF DATA, OR BUSINESS INTERRUPTION. NO CLAIM, SUIT OR ACTION SHALL BE BROUGHT AGAINST TI MORE THAN ONE YEAR AFTER THE RELATED CAUSE OF ACTION HAS OCCURRED.
- 8.2 *Specific Limitations.* IN NO EVENT SHALL TI'S AGGREGATE LIABILITY FROM ANY WARRANTY OR OTHER OBLIGATION ARISING OUT OF OR IN CONNECTION WITH THESE TERMS AND CONDITIONS, OR ANY USE OF ANY TI EVM PROVIDED HEREUNDER, EXCEED THE TOTAL AMOUNT PAID TO TI FOR THE PARTICULAR UNITS SOLD UNDER THESE TERMS AND CONDITIONS WITH RESPECT TO WHICH LOSSES OR DAMAGES ARE CLAIMED. THE EXISTENCE OF MORE THAN ONE CLAIM AGAINST THE PARTICULAR UNITS SOLD TO USER UNDER THESE TERMS AND CONDITIONS SHALL NOT ENLARGE OR EXTEND THIS LIMIT.
9. *Return Policy.* Except as otherwise provided, TI does not offer any refunds, returns, or exchanges. Furthermore, no return of EVM(s) will be accepted if the package has been opened and no return of the EVM(s) will be accepted if they are damaged or otherwise not in a resalable condition. If User feels it has been incorrectly charged for the EVM(s) it ordered or that delivery violates the applicable order, User should contact TI. All refunds will be made in full within thirty (30) working days from the return of the components(s), excluding any postage or packaging costs.
10. *Governing Law:* These terms and conditions shall be governed by and interpreted in accordance with the laws of the State of Texas, without reference to conflict-of-laws principles. User agrees that non-exclusive jurisdiction for any dispute arising out of or relating to these terms and conditions lies within courts located in the State of Texas and consents to venue in Dallas County, Texas. Notwithstanding the foregoing, any judgment may be enforced in any United States or foreign court, and TI may seek injunctive relief in any United States or foreign court.

Mailing Address: Texas Instruments, Post Office Box 655303, Dallas, Texas 75265
Copyright © 2015, Texas Instruments Incorporated

IMPORTANT NOTICE

Texas Instruments Incorporated and its subsidiaries (TI) reserve the right to make corrections, enhancements, improvements and other changes to its semiconductor products and services per JESD46, latest issue, and to discontinue any product or service per JESD48, latest issue. Buyers should obtain the latest relevant information before placing orders and should verify that such information is current and complete. All semiconductor products (also referred to herein as "components") are sold subject to TI's terms and conditions of sale supplied at the time of order acknowledgment.

TI warrants performance of its components to the specifications applicable at the time of sale, in accordance with the warranty in TI's terms and conditions of sale of semiconductor products. Testing and other quality control techniques are used to the extent TI deems necessary to support this warranty. Except where mandated by applicable law, testing of all parameters of each component is not necessarily performed.

TI assumes no liability for applications assistance or the design of Buyers' products. Buyers are responsible for their products and applications using TI components. To minimize the risks associated with Buyers' products and applications, Buyers should provide adequate design and operating safeguards.

TI does not warrant or represent that any license, either express or implied, is granted under any patent right, copyright, mask work right, or other intellectual property right relating to any combination, machine, or process in which TI components or services are used. Information published by TI regarding third-party products or services does not constitute a license to use such products or services or a warranty or endorsement thereof. Use of such information may require a license from a third party under the patents or other intellectual property of the third party, or a license from TI under the patents or other intellectual property of TI.

Reproduction of significant portions of TI information in TI data books or data sheets is permissible only if reproduction is without alteration and is accompanied by all associated warranties, conditions, limitations, and notices. TI is not responsible or liable for such altered documentation. Information of third parties may be subject to additional restrictions.

Resale of TI components or services with statements different from or beyond the parameters stated by TI for that component or service voids all express and any implied warranties for the associated TI component or service and is an unfair and deceptive business practice. TI is not responsible or liable for any such statements.

Buyer acknowledges and agrees that it is solely responsible for compliance with all legal, regulatory and safety-related requirements concerning its products, and any use of TI components in its applications, notwithstanding any applications-related information or support that may be provided by TI. Buyer represents and agrees that it has all the necessary expertise to create and implement safeguards which anticipate dangerous consequences of failures, monitor failures and their consequences, lessen the likelihood of failures that might cause harm and take appropriate remedial actions. Buyer will fully indemnify TI and its representatives against any damages arising out of the use of any TI components in safety-critical applications.

In some cases, TI components may be promoted specifically to facilitate safety-related applications. With such components, TI's goal is to help enable customers to design and create their own end-product solutions that meet applicable functional safety standards and requirements. Nonetheless, such components are subject to these terms.

No TI components are authorized for use in FDA Class III (or similar life-critical medical equipment) unless authorized officers of the parties have executed a special agreement specifically governing such use.

Only those TI components which TI has specifically designated as military grade or "enhanced plastic" are designed and intended for use in military/aerospace applications or environments. Buyer acknowledges and agrees that any military or aerospace use of TI components which have **not** been so designated is solely at the Buyer's risk, and that Buyer is solely responsible for compliance with all legal and regulatory requirements in connection with such use.

TI has specifically designated certain components as meeting ISO/TS16949 requirements, mainly for automotive use. In any case of use of non-designated products, TI will not be responsible for any failure to meet ISO/TS16949.

Products

Audio	www.ti.com/audio
Amplifiers	amplifier.ti.com
Data Converters	dataconverter.ti.com
DLP® Products	www.dlp.com
DSP	dsp.ti.com
Clocks and Timers	www.ti.com/clocks
Interface	interface.ti.com
Logic	logic.ti.com
Power Mgmt	power.ti.com
Microcontrollers	microcontroller.ti.com
RFID	www.ti-rfid.com
OMAP Applications Processors	www.ti.com/omap
Wireless Connectivity	www.ti.com/wirelessconnectivity

Applications

Automotive and Transportation	www.ti.com/automotive
Communications and Telecom	www.ti.com/communications
Computers and Peripherals	www.ti.com/computers
Consumer Electronics	www.ti.com/consumer-apps
Energy and Lighting	www.ti.com/energy
Industrial	www.ti.com/industrial
Medical	www.ti.com/medical
Security	www.ti.com/security
Space, Avionics and Defense	www.ti.com/space-avionics-defense
Video and Imaging	www.ti.com/video

TI E2E Community

e2e.ti.com