

This document is the property of Amphenol Corporation and is delivered on the express condition that it is not to be disclosed, reproduced or used, in whole or in part, for manufacture or sale by anyone other than Amphenol Corporation without its prior consent, and that no right is granted to disclose or to use any information in this document.

The marking on this product doesn't contain environmental hazardous materials per Material Specification 55-00259 for Sony GP compliant or per directive 2011/65/EU for RoHS compliant.



ORIGINAL



REVISIONS				
SYM	ECN No.	DESCRIPTION	DATE	APPROVED
A	NE-16291	RELEASE REVISION	12/16/2016	Arron Lin
B	NE-18234	UPDATE 12.50 & 5.12 DIM TOLERANCE TO 0.1mm	11/09/2018	Roger Tsai

NOTES:

- MATERIAL:
 - HOUSING: HIGH TEMPERATURE THERMO PLASTIC, OPTIONS.
 - UL94V-0, COLOR: OPTIONS.
 - TERMINAL: PHOSPHOR BRONZE.
 - SHELL: COPPER ALLOY.
 - MIDDLE SHELL: COPPER ALLOY.
 - REAR SHELL: COPPER ALLOY.
- FINISH:
 - TERMINAL:
 - CONTACT AREA: SELECTIVE GOLD PLATING;
 - SOLDERING AREA: MATTE TIN PLATING 100 u" THICKNESS MIN.;
 - UNDER PLATING: NICKEL PLATING 50 u" THICKNESS MIN.OVERALL.
 - SHELL:
 - PLATING: NICKEL PLATING 50 u" THICKNESS MIN.OVERALL.
 - MIDDLE SHELL:
 - PLATING: NICKEL PLATING 50 u" THICKNESS MIN.OVERALL.
 - REAR SHELL:
 - PLATING: NICKEL PLATING 50 u" THICKNESS MIN.OVERALL.
- PRODUCT SPECIFICATION REFER TO : PS-7329
- FOR WAVE SOLDERING PROCESS ONLY.
- THIS PRODUCT DOESN'T CONTAIN ENVIRONMENTAL HAZARDOUS PER DIRECTIVE 2011/65/EU FOR RoHS COMPLIANT.

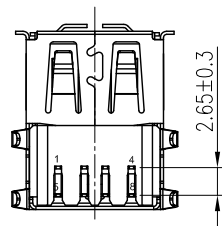
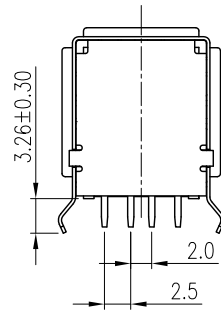
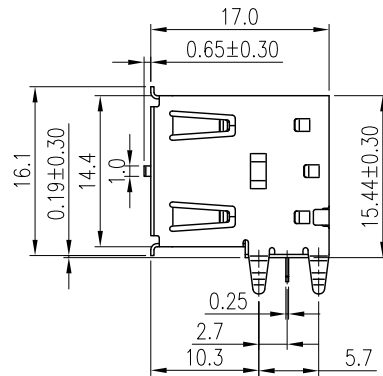
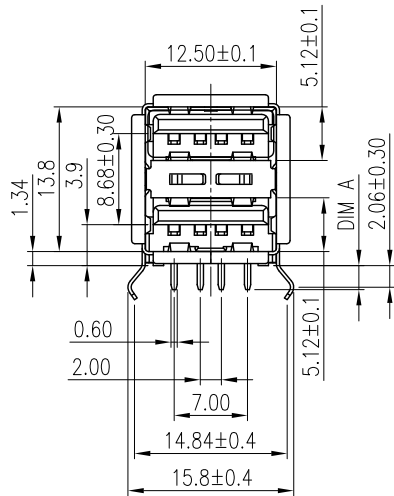
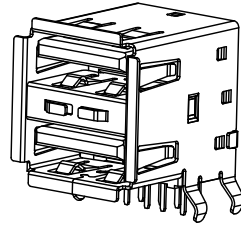
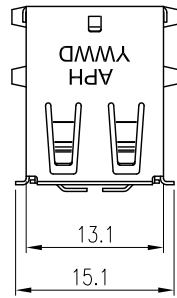

P/N : GSB122 X X X FR SPEU
 HOUSING MATERIAL
 L: LCP

CONTACT FINISH
 1: GOLD FLASH
 2: 30 u" GOLD
 3: XXX
 4: XXXX

COLOR OF HOUSING / TAIL (DIM A)
 0: NATURAL WHITE (DIM A=2.7)
 1: BLACK (DIM A=2.7)

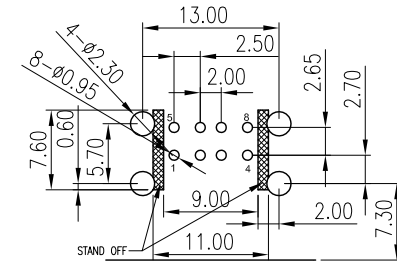

RECOMMENDED PCB LAYOUT
 TOP VIEW
 TOLERANCE: ±0.05mm
 PCB THICKNESS: 1.60±0.05mm

TOLERANCE	APPROVALS	DATE	TITLE	UNIT	SIZE	PART No.
X. X.X ±0.30 X.XX ±0.20 X.XXX ±0.10	DRAWN Debby Hung	11/09/2018	USB A TYPE, STACK R/A DIP, RECEPTACLE W/ FRONT SPRING, REAR SHELL	mm	A3	Amphenol® Amphenol Corporation Amphenol Taiwan Corporation
	CHECKED Sandy Wu	11/09/2018		SCALE	SHEET	
	APPROVED Roger Tsai	11/09/2018		NA	1 OF 2	
ANGULAR ±1° UNLESS OTHERWISE SPECIFIED	DWG TYPE CUST DWG	PROJECT CODE OTHER				REV. B

This document is the property of Amphenol Corporation and is delivered on the express condition that it is not to be disclosed, reproduced or used, in whole or in part, for manufacture or sale by anyone other than Amphenol Corporation without its prior consent, and that no right is granted to disclose or to use any information in this document.
 The marking on this product doesn't contain environmental hazardous materials per Material Specification 55-00259 for Sony GP compliant or per directive 2011/65/EU for RoHS compliant.



ORIGINAL



REVISIONS				
SYM	ECN No.	DESCRIPTION	DATE	APPROVED
A	NE-16291	RELEASE REVISION	12/16/2016	Arron Lin
B	NE-18234	UPDATE 12.50 & 5.12 DIM TOLERANCE TO 0.1mm	11/09/2018	Roger Tsai

12 PCS TRAY/CARTON

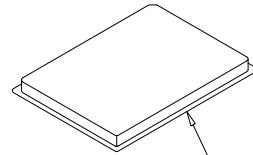
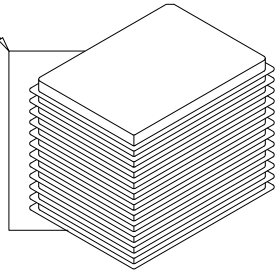

100 PCS/TARY

TRAY SIZE	PARTS PER CARTON<S.P.Q>	PARTS PER TRAY	TOTEL TRAY PER CARTON
225 X 235 X 22.5	2400	100	24

NOTES:

1. STAPLES SHOULD ONLY BE USED TO SET UP CARTON. ALL CARTON CLOSUERS MUST BE DONE WITH TAPE.
2. FILL PACKAGING TRAYS WITH THE QUANTITIES AS INDICATED IN THE CHART.
3. SHIPPING CARTON DIMENSION: 520 X 273 X 310 MM.
4. NET WEIGHT: 12.5 KG.
GROSS WEIGHT: 15.8 KG.

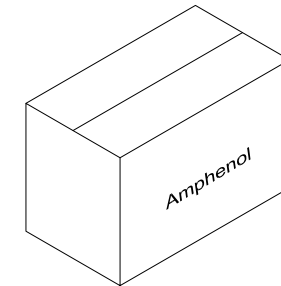
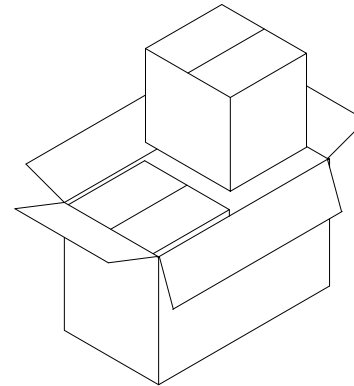
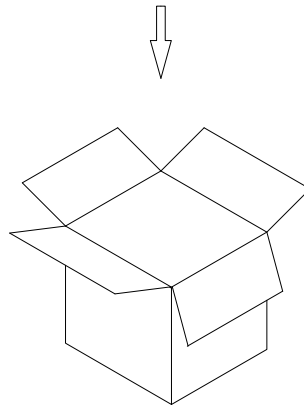

TOLERANCE		APPROVALS		DATE	TITLE		Amphenol®							
X.		DRAWN	Debby Hung	11/09/2018	USB A TYPE, STACK R/A DIP, RECEPTACLE W/ FRONT SPRING, REAR SHELL		Amphenol Corporation Amphenol Taiwan Corporation							
X.X	±0.30	CHECKED	Sandy Wu	11/09/2018										
X.XX	±0.20	APPROVED	Roger Tsai	11/09/2018										
X.XXX	±0.10	UNLESS OTHERWISE SPECIFIED		DWG TYPE	CUST DWG	PROJECT CODE	OTHER	UNIT	mm	SIZE	A3	PART No.	GSB122XXXFRSPEU	
ANGULAR	±1°							SCALE	NA	SHEET	2 OF 2	DWG No.	GSB122XXXFRSPEU	
												REV.	B	