

THIS DRAWING IS UNPUBLISHED. RELEASED FOR PUBLICATION 20
 © COPYRIGHT 20 BY - ALL RIGHTS RESERVED.

REVISIONS					
P	LTR	DESCRIPTION	DATE	DWN	APVD
	A	INITIAL RELEASE	06JUN2019	OL	SZ

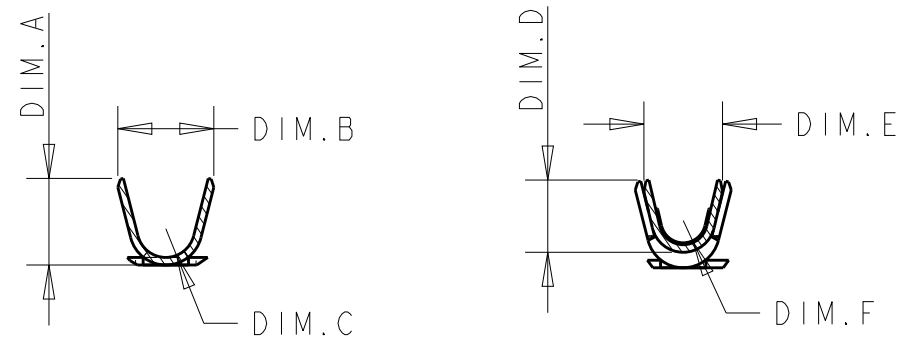
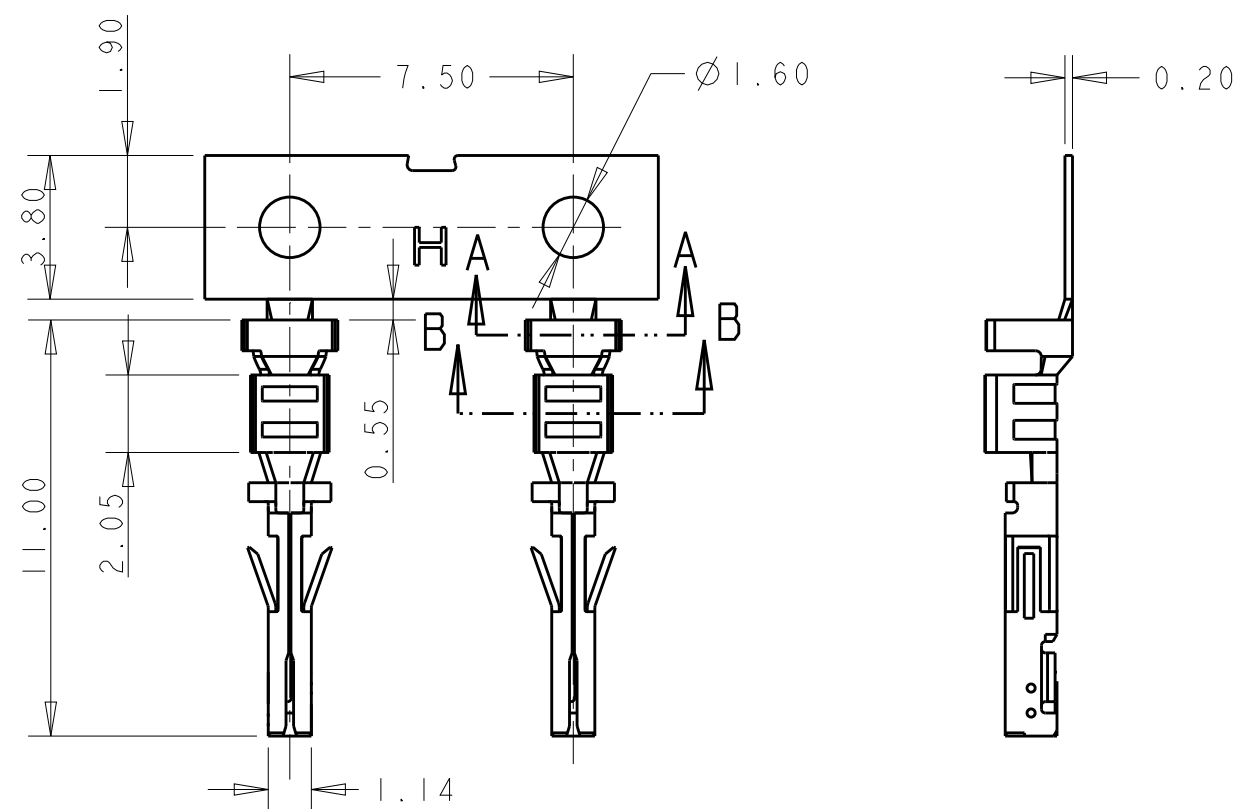

- SECTION A-A
 NOTES:
 1. MATERIAL: COPPER ALLOY.
 2. FINISH: SEE PART NUMBER LIST.
 3. THIS RECEPTACLE TERMINAL TO BE USED WITH RECEPTACLE HOUSING 2204748.
 4. PACKAGED IN MATERIAL BELT/STRIP.

NICKEL UNDERPLATING OVER ALL FOR ALL PART NUMBERS; *: PLATING ON CONTACT AREA AND CRIMPING AREA 1: GOLD FLASH ON CONTACT AREA; 100u" MIN. BRIGHT TIN PLATING ON CRIMPING AREA; 2: 5u" MIN. GOLD PLATING ON CONTACT AREA; 100u" MIN. BRIGHT TIN PLATING ON CRIMPING AREA; 3: 10u" MIN. GOLD PLATING ON CONTACT AREA; 100u" MIN. BRIGHT TIN PLATING ON CRIMPING AREA; 4: 15u" MIN. GOLD PLATING ON CONTACT AREA; 100u" MIN. BRIGHT TIN PLATING ON CRIMPING AREA; 5: 30u" MIN. GOLD PLATING ON CONTACT AREA; 100u" MIN. BRIGHT TIN PLATING ON CRIMPING AREA; 7: 100u" BRIGHT TIN PLATING OVER ALL; 8: 100u" MATTE TIN PLATING OVER ALL.	1.27	26~30 AWG	0.51	1.65	1.47	0.64	2.10	1.91	2-2204749-*
	1.85	20~24 AWG	0.64	2.08	1.91	0.76	2.54	2.29	1-2204749-*
	2.40	16~20 AWG	0.76	2.48	2.31	0.88	3.14	2.94	2204749-*
REMARK	MAX INSULATION	WIRE SIZE	DIM.F	DIM.E ±0.30	DIM.D ±0.30	DIM.C	DIM.B ±0.30	DIM.A ±0.30	PART NUMBER

THIS DRAWING IS A CONTROLLED DOCUMENT.		DWN 9-Aug-18 RADAR SUN		
DIMENSIONS: mm		CHK 9-Aug-18 SUNY ZHAO		
TOLERANCES UNLESS OTHERWISE SPECIFIED:		APVD 9-Aug-18 SUNY ZHAO	NAME ELCON MICRO POWER CONNECTOR, RECEPTACLE, TERMINAL, 3.00MM PITCH, 2XN CIRCUITS	
0 PLC ±-		PRODUCT SPEC	SIZE	
1 PLC ±±0.30		APPLICATION SPEC	CAGE CODE	
2 PLC ±±0.20		WEIGHT	DRAWING NO	
3 PLC ±-		CUSTOMER DRAWING	A300779	
4 PLC ±-		SCALE 5:1	SHEET 1 OF 1	
ANGLES ±-		RESTRICTED TO	REV A	
FINISH		C=2204749		