

SF2331B

**246 MHz
SAW Filter**

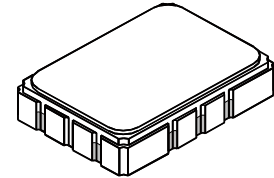

SMP-03

- **Narrow-band SAW Filter**
- **5 x 7 mm Surface-mount Package**
- **Complies with Directive 2002/95/EC (RoHS)**
- **Moisture Sensitivity Level: 1**

Absolute Maximum Ratings

Rating	Value	Units
Maximum Incident Power in Passband	0	dBm
Maximum DC Voltage on any Non-ground Terminals	3	VDC
Storage Temperature Range in Tape and Reel	-40 to +85	°C
Suitable for Lead-free Soldering - Maximum Soldering Profile	260 °C for 30 s	

Electrical Characteristics

Characteristic	Sym	Notes	Min	Typ	Max	Units
Center Frequency	f_C			246		MHz
Minimum Insertion Loss	IL_{MIN}			5.0	6.5	dB
3 dB Bandwidth	BW_3			600		kHz
Amplitude Ripple, $f_C \pm 225$ kHz				1.2	2.0	dB _{P-P}
Rejection Referenced to IL_{MIN} :						dB
10 MHz to f_C -20 MHz			45.0	55.0		
f_C -20MHz to f_C -1.2MHz			40.0	45.0		
f_C +1.2MHz to f_C +20MHz			40.0	45.0		
f_C +20MHz to 1GHz			45.0	55.0		
Operating Temperature Range			-20		+70	°C

Case Style	SMP-03 7 x 5 mm Nominal Footprint					
Lid Symbolization (Y=year, WW=week, S = shift, ## = Sequence Code) dot=pin 1 indicator	RFM, SF2331B, YYWWS##					
Standard Reel Quantity	Reel Size 7 Inch					500 Pieces/Reel
	Reel Size 13 Inch					2000 Pieces/Reel

Electrical Connections

Connection	Terminals
Input Port	10
Output Port	5
Ground	All others

 **CAUTION: Electrostatic Sensitive Device. Observe precautions for handling.**

NOTES:

1. The design, manufacturing process, and specifications of this device are subject to change.
2. US or International patents may apply.
3. RoHS compliant from the first date of manufacture.

Typical Tuning Network

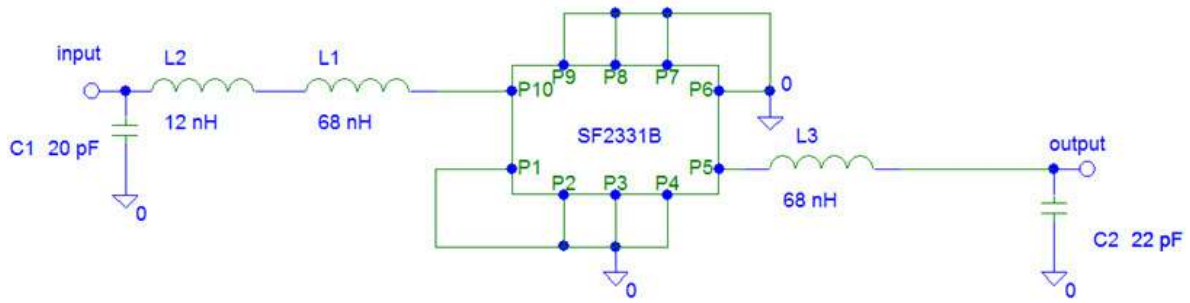

Filter Response Plot

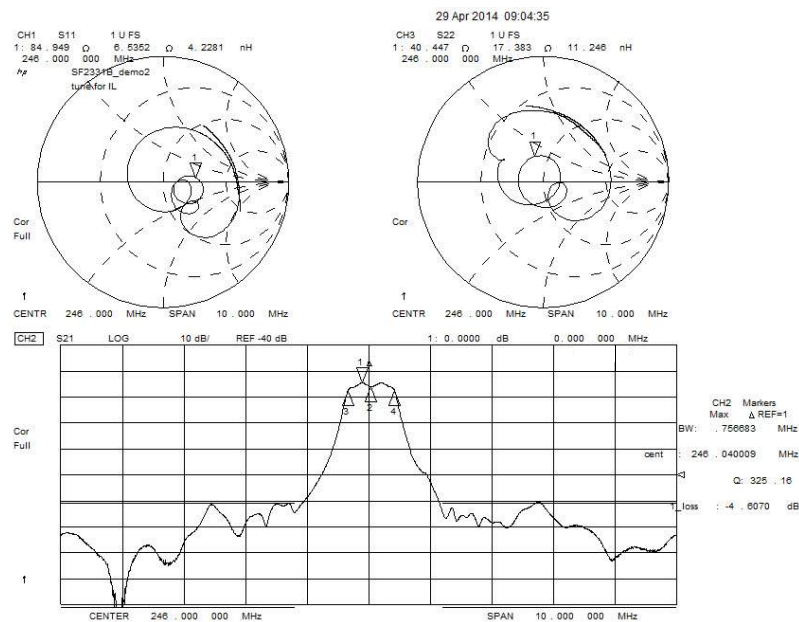
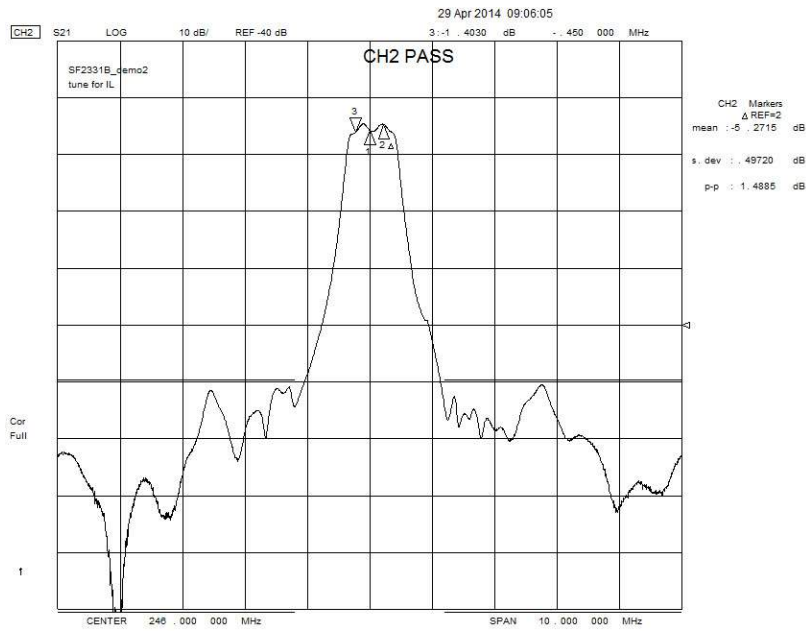

SMP-03 10-Terminal Ceramic Surface-mount Case

5 x 7 mm Nominal Footprint

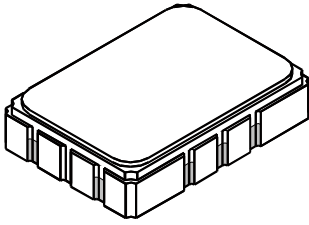

Recommended PCB Footprint

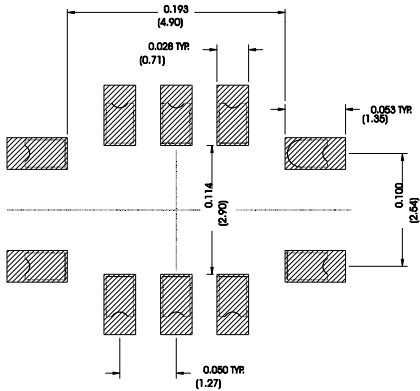

Case Dimensions						
Dimension	mm			Inches		
	Min	Nom	Max	Min	Nom	Max
A	6.80	7.00	7.20	0.268	0.276	0.283
B	4.80	5.00	5.20	0.189	0.197	0.205
C	-	1.65	2.00	-	0.065	0.079
D	0.47	0.60	0.73	0.019	0.024	0.029
E	2.41	2.54	2.67	0.095	0.100	0.105
H	0.87	1.0	1.13	0.034	0.039	0.044
J	4.87	5.00	5.13	0.192	0.197	0.202
K	2.87	3.00	3.13	0.113	0.118	0.123
P	1.14	1.27	1.40	0.045	0.050	0.055

Electrical Connections		
Connection		Terminals
Port 1	Single-ended Input	10
Port 2	Single-ended Output	5
	Ground	All others

Case Materials	
Solder Pad Plating	0.3 to 1.0 μm Gold over 1.27 to 8.89 μm Nickel
Lid Plating	2.0 to 3.0 μm Nickel
Body	Al_2O_3 Ceramic

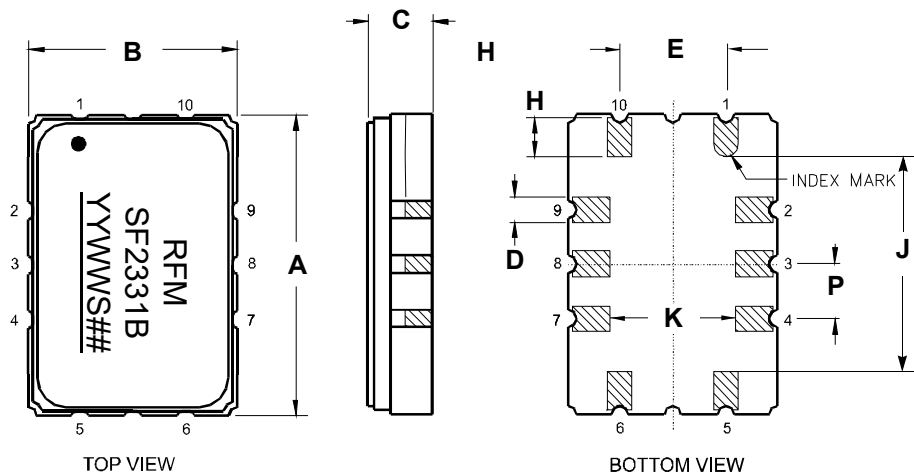

Tape and Reel Specifications

Tape and Reel Standard per ANSI/EIA-481

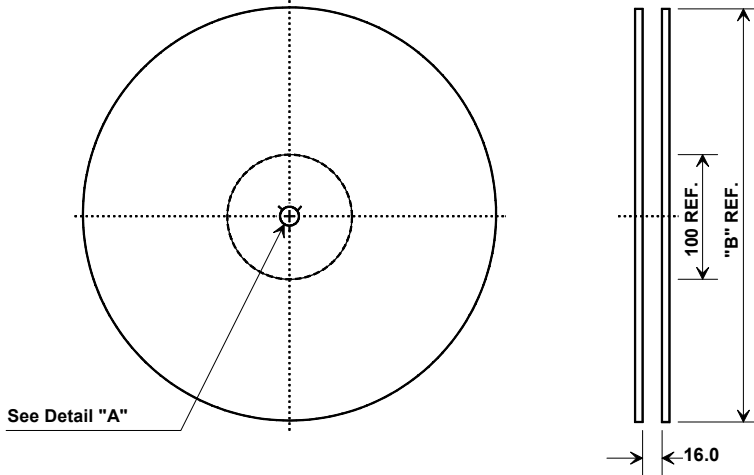

"B" Nominal Size		Quantity Per Reel
Inches	millimeters	
7	178	500
13	330	2000

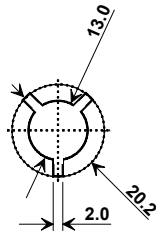

COMPONENT ORIENTATION and DIMENSIONS

Carrier Tape Dimensions	
Ao	5.6 mm
Bo	7.6 mm
Ko	2.0 mm
Pitch	8.0 mm
W	16.0 mm

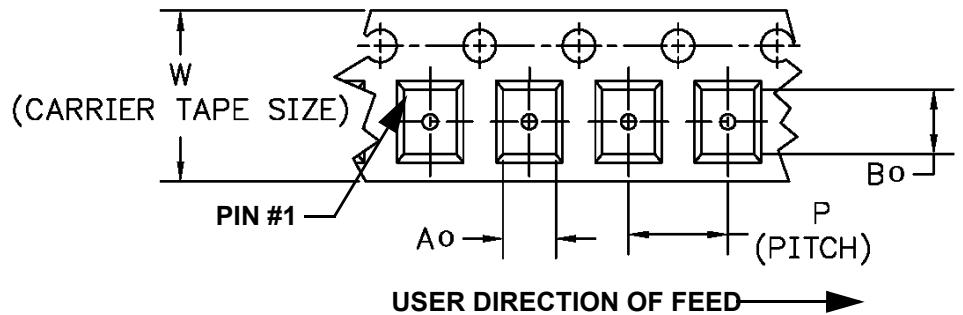
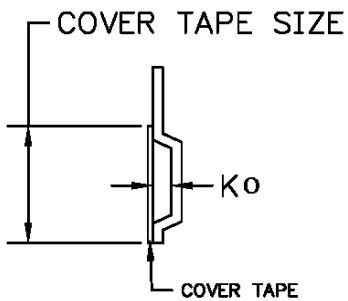

Recommended Reflow Profile

1. Preheating shall be fixed at 150~180°C for 60~90 seconds.
2. Ascending time to preheating temperature 150°C shall be 30 seconds min.
3. Heating shall be fixed at 220°C for 50~80 seconds and at 260°C +0/-5°C peak (10 seconds).
4. Time: 5 times maximum.

