

## SPECIFICATION

Part No. : **CAB.953**

Product Name : Taoglas Low Loss Cable Assembly  
N Type Jack with O-Ring to 5000mm(16.4') ULC-200 to SMA(M)

Photo :





# 1. Cable Insertion Loss



# 2. ULC-200 Cable Specification

## 2.1 Drawing – Cross Section

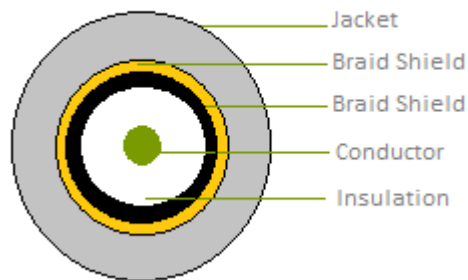

## 2.2 Structure and Dimensions

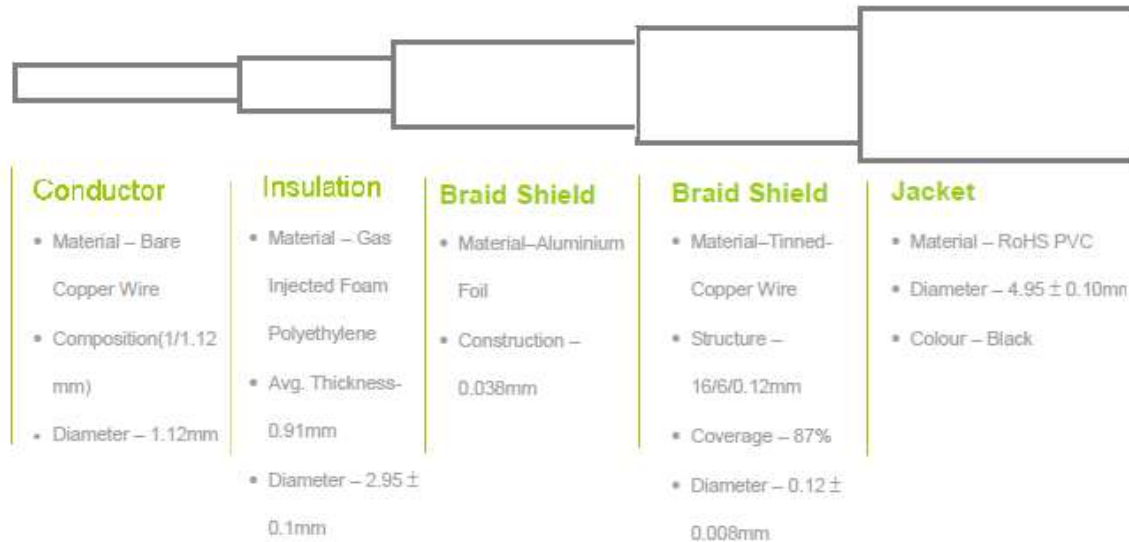

## 2.3 Electrical & Physical Specification

### The Characteristic of ULC-200 Coaxial Cable

Insulation Resistance:	1000 MΩ-Km (Min)					
Capacitance	80.4 ± 3 pF/m					
Nom. Impedance	50 ± 3 Ω					
Attenuation (dB/100M)	500MHZ	1000MHZ	1500MHZ	2000MHZ	2500MHZ	3000MHZ
	24.1	34.4	42.4	49.3	55.4	60.9

### 3. Technical Drawing

#### 3.1 CAB.953

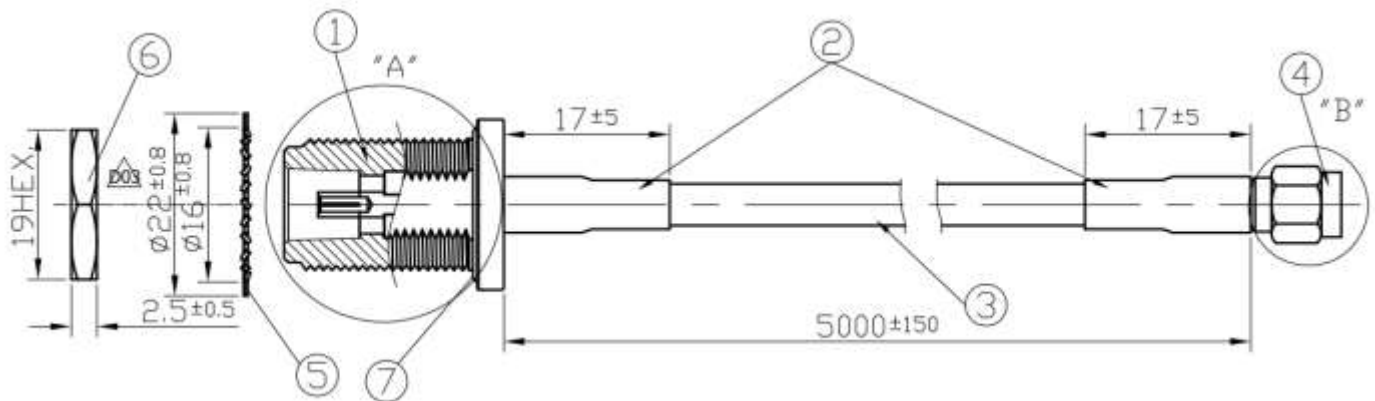

	Name	Material	Finish	QTY
1	N Type (F) ST	Brass	Ni Plated	1
2	Heat Shrink Tube	PE	Black	2
3	ULC200	PVC	Black	1
4	SMA(M)ST Connector	Brass	Gold	1
5	SMA Washer	Brass	Ni Plated	1
6	SMA Nut	Brass	Ni Plated	1
7	O-Ring	Brass	Black	1

### 3.2 Connectors

