

ITEM	Q'TY	PART NUMBER	PART DESCRIPTION
1	1	PM3	LED Holder, Panel Mount, Press Fit, (3mm)
2	1	3XXDL-S	T-1 (3mm) Non-Flange Low Current LED, See Page 2.
3	1	BWS24-1061-RD	24AWG Wire Lead U.L. 1061, Red
4	1	BWS24-1061-BK	24AWG Wire Lead U.L. 1061, Black

REV.	DESCRIPTION	DATE	APPROVED
A	Engineering Release	06/14/04	M. C.
B	Updated Model to Non-Stripped and PN Example	06/18/08	M. C.
C	Added -S to 3XXDL in BOM	12/19/12	T. Y.

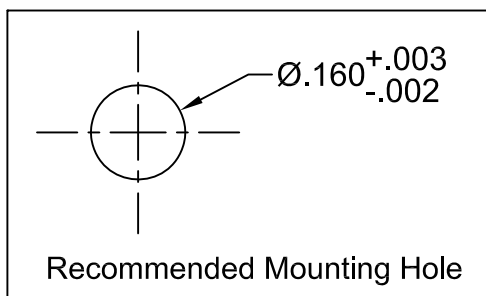

EXAMPLE:  
**PM3RDLW6.5-NS**  
 Series | LED Color & Lens Appearance. | Low Current. | Wire Length "X.X" | Non-Stripped Wires

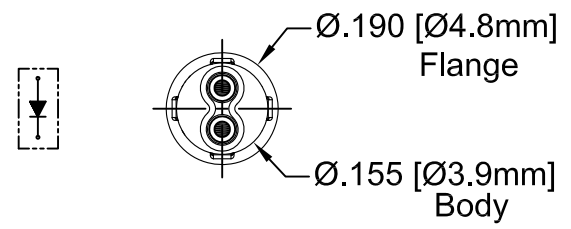
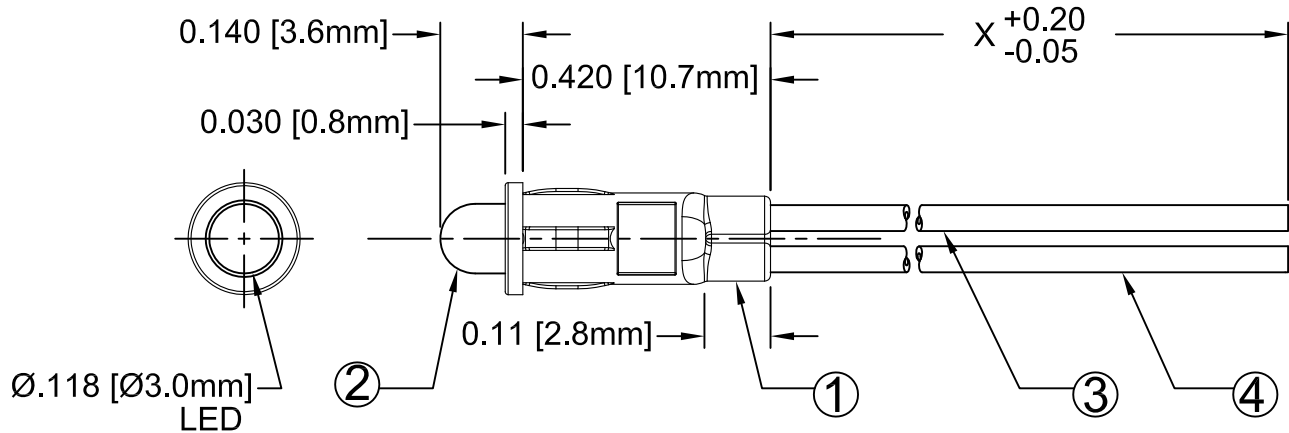
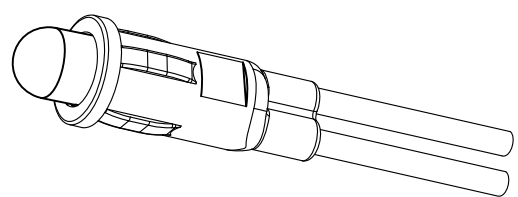



### ABSOLUTE MAXIMUM RATINGS (Ta = 25°C)

REVERSE VOLTAGE	5V
REVERSE CURRENT ( VR=5V)	100µA
OPERATING TEMPERATURE RANGE	-25°C ~ 85°C
STORAGE TEMPERATURE	-30°C ~ 100°C
LEAD SOLDERING TEMPERATURE (1/16" FROM BODY)	260°C for 5 Seconds

STANDARD TOLERANCE ( UNLESS OTHERWISE SPECIFIED )		<b>BIVAR</b> <sup>®</sup> 4 THOMAS, IRVINE, CA. 92618 TEL: (949) 951-8808 FAX: (949) 951-3974	
DECIMALS	ANGULAR		
.X ± .1	X° ± 1°	<b>TITLE: T-1 (3mm) PANEL MOUNT ASSY NON STRIPPED WIRE</b>	
.XX ± .02			
.XXX ± .010			
DESIGNED: <b>David Green</b>	DATE: <b>06/14/04</b>	<b>PART NO:</b> PM3XXDLWX.X-NS	REVISION: <b>C</b>
CHECKED: <b>T. Yin</b>	DATE: <b>06/14/04</b>	<b>CAGE CODE : 32559</b>	<b>SHEET # 1 OF 2</b>
CAD GENERATED DOCUMENT, DO NOT MEASURE DRAWING.			

REV.	DESCRIPTION	DATE	APPROVED
	SEE SHEET#1.		

ASSEMBLY PART NO.	LED Part No.	Chip			Lens Appearance	Absolute Max. Ratings			Electro-Optical Data @ 2ma			Viewing Angle (Deg)
		Material	Peak Wave Length $\lambda_p$ (nm)	Emitted Color		$\Delta\lambda$ (nm)	Pd (mW)	If (mA)	Vf (V)		Iv (mcd)	
									TYP	MAX	TYP	
PM3BVDLWX.X-NS	3BVDL-S	GaN/SiC	430	BLUE	DIFFUSED	65	10	5	3.5	4.0	6.0	45
PM3GDLWX.X-NS	3GDL-S	GaP/GaP	565	GREEN	DIFFUSED	30	10	5	1.9	2.2	6.0	45
PM3PGDLWX.X-NS	3PGDL-S	GaP/GaP	585	PURE GREEN	DIFFUSED	25	10	5	1.9	2.2	4.0	45
PM3YDLWX.X-NS	3YDL-S	GaAsP/GaP	585	YELLOW	DIFFUSED	35	10	5	1.9	2.2	4.0	45
PM3ADLWX.X-NS	3ADL-S	GaAsP/GaP	610	AMBER	DIFFUSED	35	10	5	1.9	2.2	6.0	45
PM3HDLWX.X-NS	3HDL-S	GaAsP/GaP	635	HE RED	DIFFUSED	45	10	5	1.8	2.2	6.0	45
PM3RDLWX.X-NS	3RDL-S	GaAsP/GaAs	655	RED	DIFFUSED	40	10	5	1.9	2.2	1.0	45

STANDARD TOLERANCE ( UNLESS OTHERWISE SPECIFIED ) $\pm 10\%$ ALL VALUES		 <b>BIVAR</b> <sup>®</sup> 4 THOMAS, IRVINE, CA. 92618 TEL: (949) 951-8808 FAX: (949) 951-3974	
ANGULAR $X^\circ \pm 5^\circ$			
		TITLE: T-1 (3mm) PANEL MOUNT ASSY NON STRIPPED WIRE	
		DESIGNED: <b>David Green</b>	DATE: <b>06/14/04</b>
CHECKED: <b>T. Yin</b>	DATE: <b>06/14/04</b>	CAGE CODE : <b>32559</b>	SHEET # <b>2 OF 2</b>
CAD GENERATED DOCUMENT, DO NOT MEASURE DRAWING.			