

REVISIONS					
REV	ECO	DESCRIPTION	DATE	BY	APPR
A1	-	RELEASE NEW DRAWING	22/MAR/19	ROOKIE	TOMMY

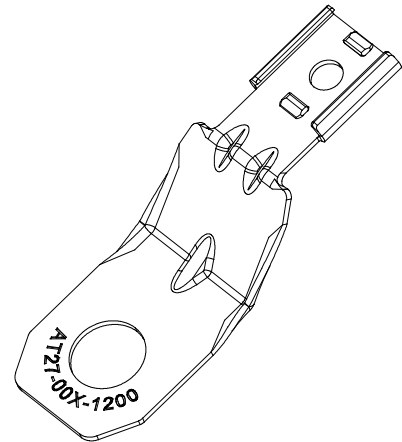

NOTES: UNLESS OTHERWISE SPECIFIED

1. USE WITH CONNECTORS

- A. AT04-2/3/4/6/12P*
 - B. ATM04-2/3/4/6/8/12P*
 - C. ATP04-2/4P*
 - D. ATV04.*
 - E. ATHD04.*
- (* = MODIFICATIONS AND/OR COLORS)

2. RoHS COMPLIANT

3. ALL DIMENSIONS ARE FOR REFERENCE USE ONLY.

PART INFORMATION:

PART NUMBER	MATERIAL	HOLE DIAMETER
AT27-003-1200	STAINLESS STEEL	11mm
AT27-004-1200	STEEL-ZINC PLATED	13mm
AT27-005-1200	STAINLESS STEEL	13mm

SEE TABLE		REF: 1027-003-1200, 1027-004-1200, 1027-005-1200	
PART NUMBER		DESCRIPTION	
QUANTITY		ITEM	
UNLESS OTHERWISE SPECIFIED:		MATERIALS LIST	
1) All dimensions are in metric (mm).		SIGNATURES	
2) Tolerances are as follows:		DATE	
1 PL DEC ±0.30		DRAWN: ROOKIE	
2 PL DEC ±0.15		CHECKED: ORION	
3 PL DEC ±0.08		ENGINEER:	
3) Note reference =		APPROVAL: TOMMY	
MATERIAL SPECIFICATIONS:		CUSTOMER:	
PROCESS SPECIFICATIONS:		THIS DRAWING IS SUPPLIED FOR INFORMATION ONLY. DESIGN FEATURES, SPECIFICATIONS AND PERFORMANCE DATA SHOWN HEREON ARE THE PROPERTY OF THE AMPHENOL CORPORATION. NO RIGHTS OF REPRODUCTION ARE IMPLIED. ALL DIMENSIONS ARE SUBJECT TO NORMAL MANUFACTURING VARIATIONS.	
NEXT ASSY:		SINE Systems Corporation	
		A Subsidiary of Amphenol Corporation 44724 Morley Drive Clinton Township, MI 48036	
		MOUNTING CLIP, A SERIES, METAL	
		SIZE: B FSCM NO. DWG NO. AT27-00X-1200 REVISION A1	
		SCALE: NONE SHEET 1 OF 1	

TITLE: MOUNTING CLIP, A1, METAL
 DWG NO: AT27-00X-1200
 REV: A1
 SH: 1
 OF: 1