

mikroDRIVE™

Manual

All Mikroelektronika's development systems feature a large number of peripheral modules expanding microcontroller's range of application and making the process of program testing easier. In addition to these modules, it is also possible to use numerous additional modules linked to the development system through the I/O port connectors. Some of these additional modules can operate as stand-alone devices without being connected to the microcontroller.

Additional Board

 **MikroElektronika**

SOFTWARE AND HARDWARE SOLUTIONS FOR EMBEDDED WORLD ...making it simple

mikroDRIVE Additional Board

The *mikroDrive* additional board enables digital outputs capable of providing current of only up to several milliamperes to be connected to devices requiring driving current of up to several hundreds milliamperes (relays, coils, stepper motors, heaters, printer hammers etc.). All this is enabled by the ULN2803 circuit provided on the *mikroDrive* board. This circuit is composed of 8 Darlingtons transistors that can power loads up to 260 W in total (8x350 mA, 95V). All these transistors are of 'open collector' type with clamp diodes. The diodes protect them against high voltage of self-induction. The *mikroDrive* additional board can be used as a stand-alone device or along with some of Mikroelektronika's development systems. This board is connected to the microcontroller's output port via a standard 2x5 connector.

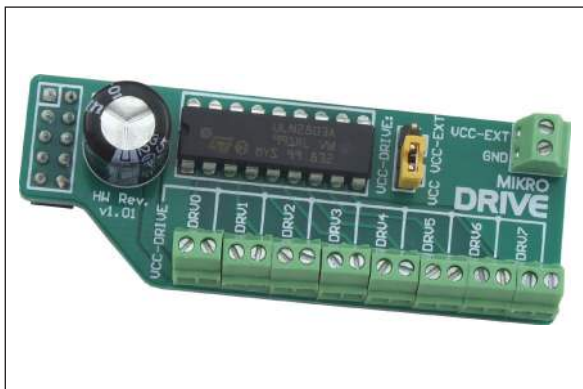

Figure 1: *mikroDRIVE* additional board

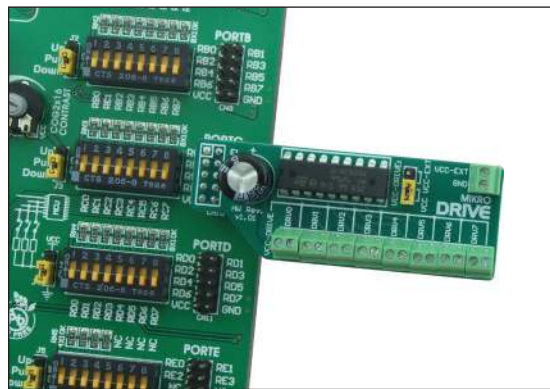

Figure 2: *mikroDRIVE* connected to a development system

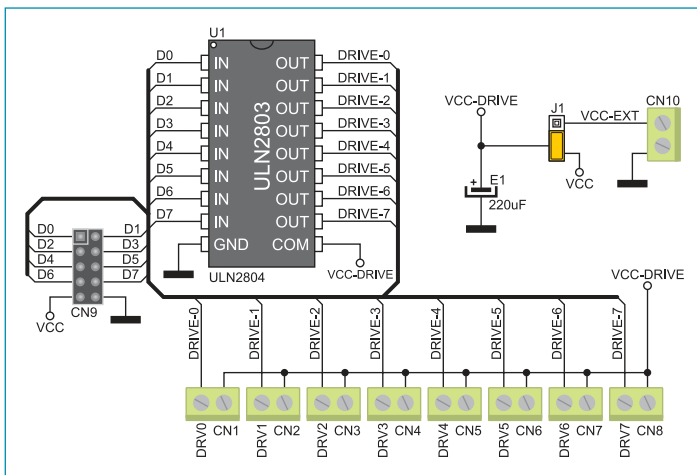

Figure 3: *mikroDRIVE* connection schematic

Jumper J1 is used to select power supply source for the ULN2803's output drivers.

When this jumper is set to the VCC position, Darlingtons drivers are powered with 5V (power supply voltage).

When this jumper is set to the VCC-EXT position, the driver's outputs are powered with voltage provided via the CN10 connector. This voltage goes up to 50V.

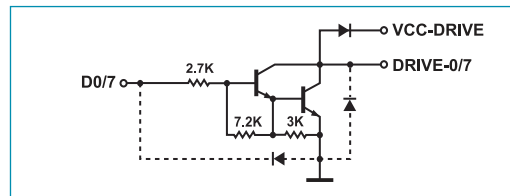

Figure 4: A ULN2803's driver connection schematic