

HANDLE AND STATOR

Glass-fibre reinforced polyamide based (PA) technopolymer, black colour, RAL 3020 red colour mobile part.

ROTOR

Zinc alloy with superficial chromate treatment.

SPRINGS

Stainless steel.

FRONT PLATE

Stainless steel.

NUT

M22x1,5 in technopolymer.

FLAT CLOSING LEVER

Zinc-plated steel, thickness 3 mm.

PACKING RING

NBR rubber.

SELF-TAPPING SCREW

Zinc-plated steel.

TWO KEYS

Nickel-plated brass, removable in two positions at 180°.

ROTATION

90° clockwise (right).

IP PROTECTION

IP 65 protection class, according to EN 60529 (see page A-18).

STANDARD EXECUTIONS

- **CSMT-A**: lock with 400 different combinations. Each lock has a couple of keys with different combination.
- **CSMTU-A**: lock with one combination. All locks have the same combination and can be opened with the same key.

FEATURES AND APPLICATIONS

Latch-type handles with anti-rotation device CSMT-A are particularly suitable for applications on cabinets or doors subject to strong vibrations. The anti-rotation device prevents the door from opening accidentally due to vibrations when the latch is not locked.

After opening the lock by means of the key (fig. 1) the handle can be turned by pulling the red body towards the operator (fig.2). By turning the handle in the lock position (fig.3), the anti-rotation mechanism is engaged automatically (fig.4).

SPECIAL EXECUTIONS ON REQUEST

Closing levers in other dimensions.



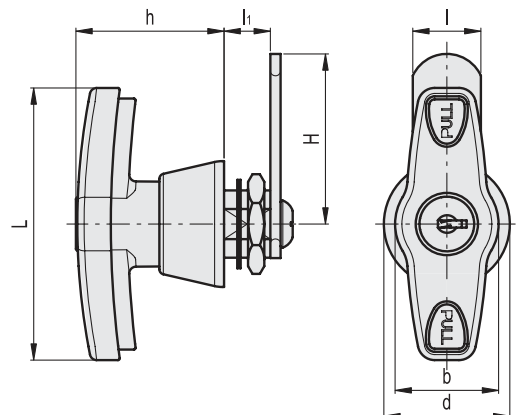
Fig.1

Fig.2

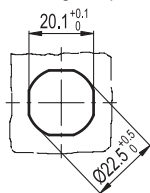


Fig.3

Fig.4



Drilling template



Conversion Table	
1 mm = 0.039 inch	
H	
mm	inch
50	1.97

Code	Description	H	L	l	l1	b	h	d	ΔΔ
421525	CSMT-A-50	50	80	20	13.5	30	43	37	130
421527	CSMTU-A-50	50	80	20	13.5	30	43	37	130