

REVISIONS				
P.	LTN	DESCRIPTION	DATE	OWN APVD
D		REVISED PER ECO-15-017922	09APR2016	AP RP
E		REVISED PER ECR-19-011161	14JAN2020	IT SH

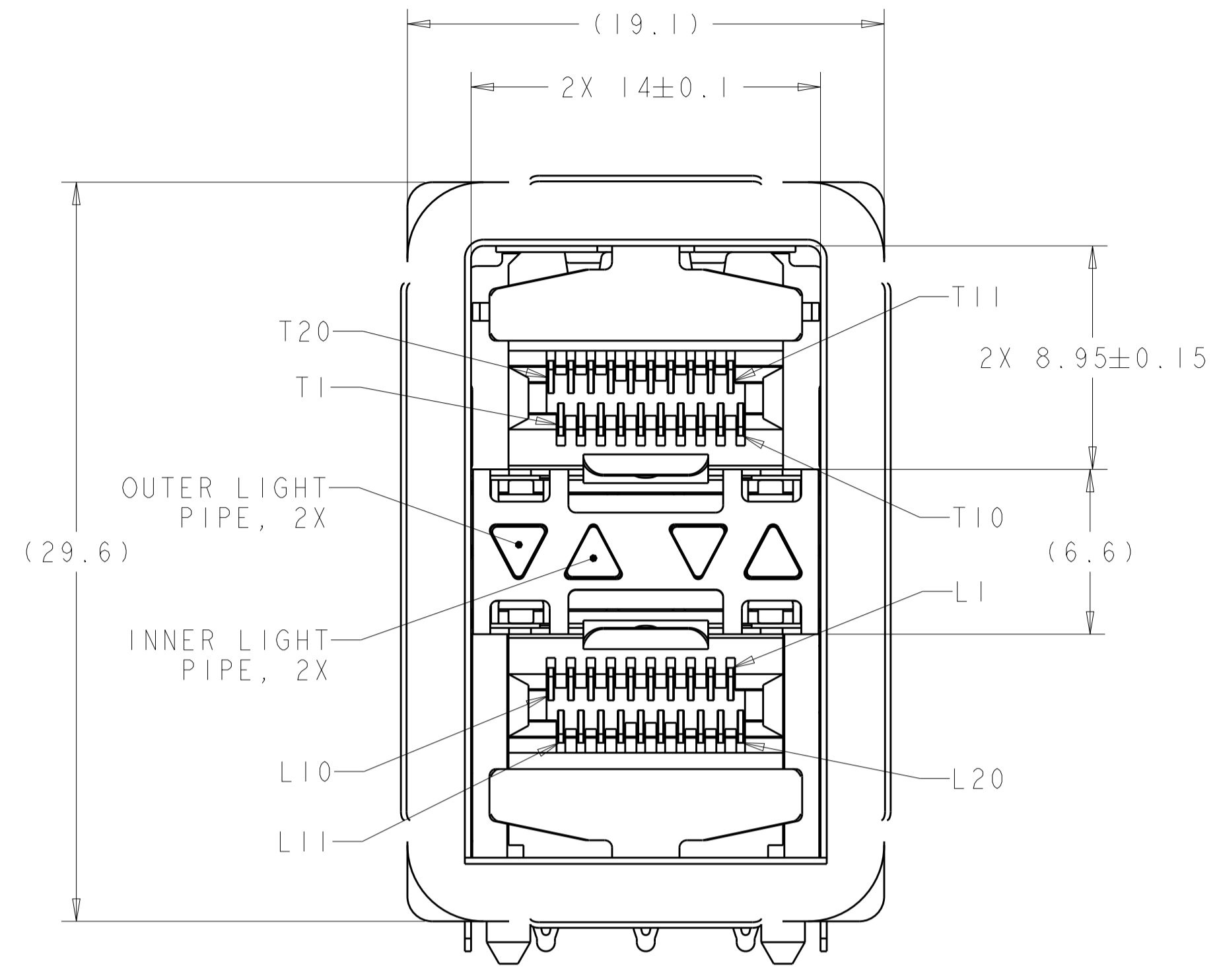

2007538-5 AS SHOWN

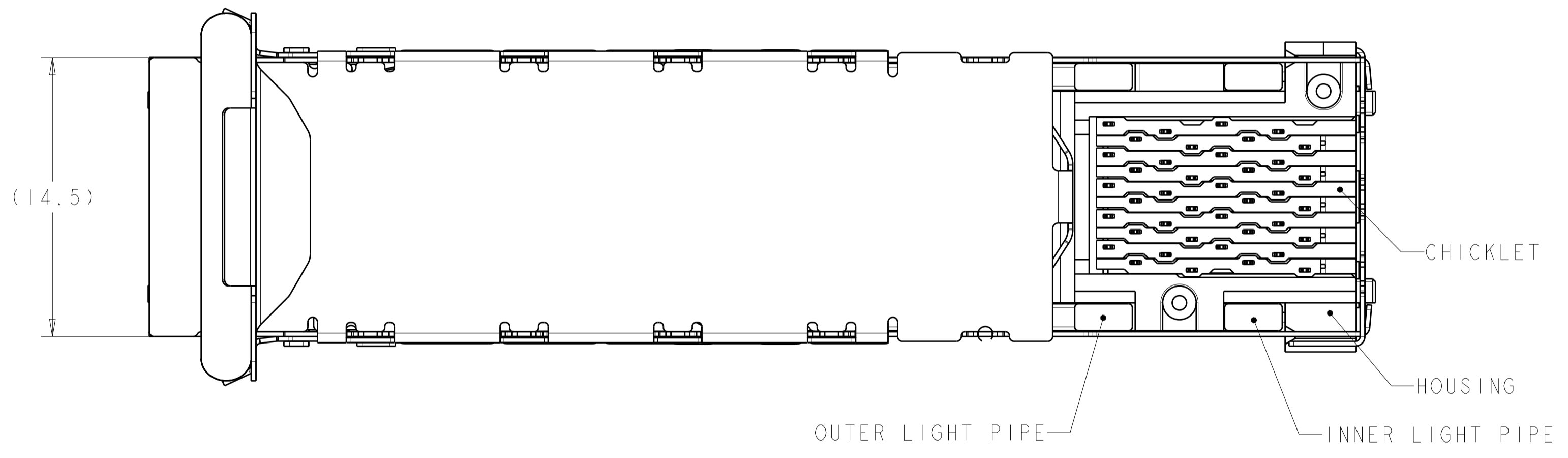
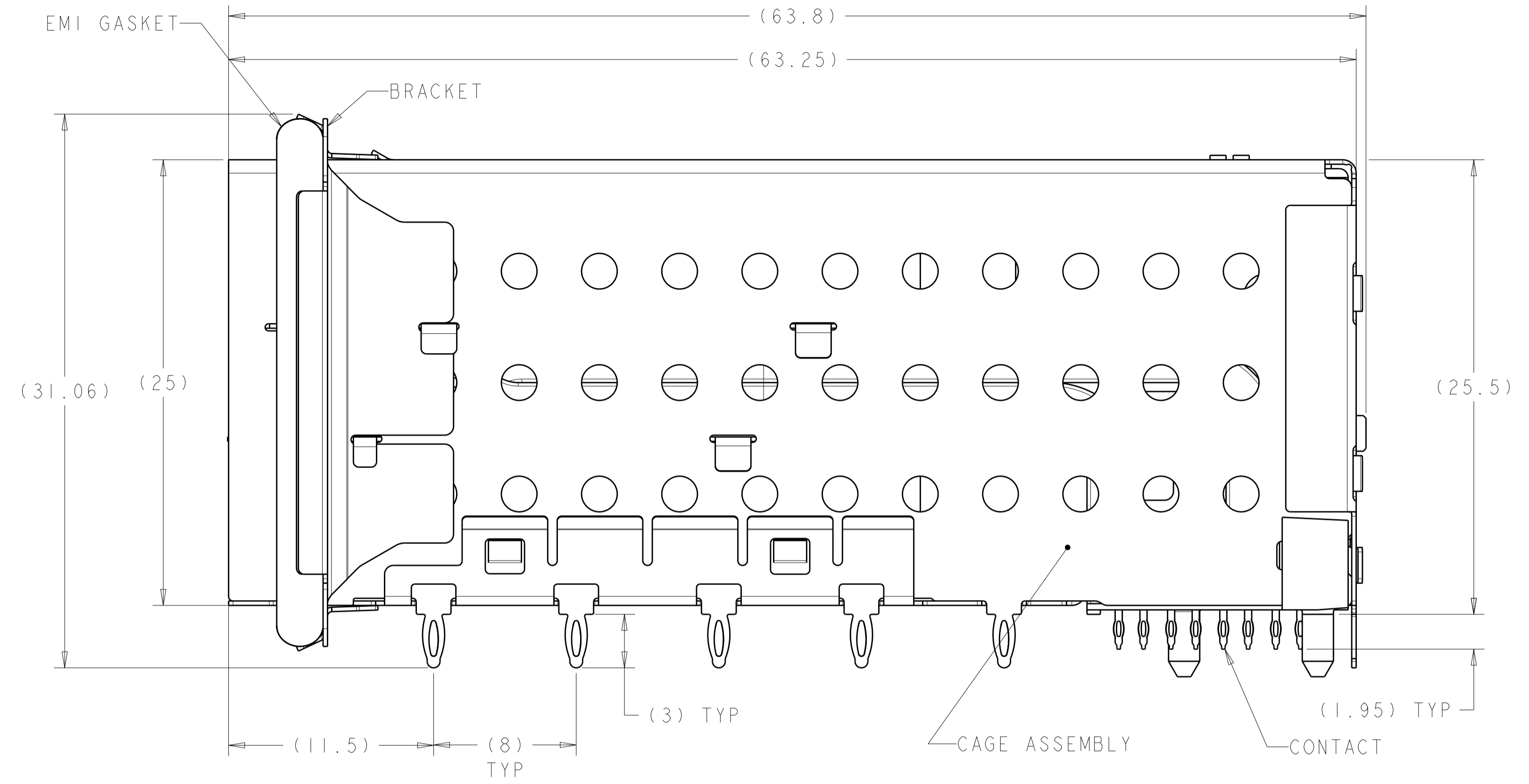

- ⚠ MATERIALS:
 CAGE ASSEMBLY- NICKEL SILVER ALLOY PER ASTM B 122.
 BRACKET- STAINLESS STEEL.
 EMI GASKET- PLATED FILLED SILICONE.
 HOUSING- BLACK LCP, UL 94V-0 RATED.
 CHICKLET- BLACK LCP, UL 94V-0 RATED.
 LIGHT PIPE- POLYCARBONATE, CLEAR.
 INSERT - (FOR LIGHT PIPE PART NUMBERS ONLY) - LCP, BLACK, UL 94V-0.
 CONTACT- COPPER ALLOY.
- ⚠ DATUM AND BASIC DIMENSIONS ESTABLISHED BY CUSTOMER.
- 3. MINIMUM PCB THICKNESS OF 1.5.
- ⚠ CONTACT FINISH- CONFORMS TO THE REQUIREMENTS OF TYCO ELECTRONICS PRODUCT SPECIFICATION 108-2331, BASED ON EIA/ECA-364-1000.01A, (CONTROLLED ENVIRONMENT APPLICATIONS) ON MATING INTERFACE, TIN-LEAD ON NEEDLE EYE.
- ⚠ CONTACT FINISH- CONFORMS TO THE REQUIREMENTS OF TYCO ELECTRONICS PRODUCT SPECIFICATION 108-2331, BASED ON EIA/ECA-364-1000.01A, (CONTROLLED ENVIRONMENT APPLICATIONS) ON MATING INTERFACE, TIN ON NEEDLE EYE.
- ⚠ FOR HOLE SIZE AND PLATINGS, SEE APPLICATION SPEC 114-13219.
- ⚠ THE ENTIRE AREA OF THE CONNECTOR FOOTPRINT, INDICATED BY THE DASHED LINE, TO BE CONSIDERED THE KEEPOUT AREA FOR COMPONENTS AND SIGNAL TRACES, TOP SIDE ONLY. TOP SIDE TRACES ALLOWED WITHIN CONNECTOR HOLE PATTERN.
- ⚠ LIGHT PIPE PAD LAYOUT IS FOR 0805 LOW PROFILE LED PACKAGE WITH A HEIGHT OF 0.8mm.
- ⚠ ADDITIONAL COMPONENT LOCATED WITHIN LATCHPLATE FOR EMI SUPPRESSION.

YES ⁹	NO	ENHANCED EMI FINISH	DESCRIPTION	PART NUMBER
			NO LIGHT PIPES	1-2007538-8
			OUTER 2 LIGHT PIPES	1-2007538-7
			INNER 2 LIGHT PIPES	1-2007538-6
			4 LIGHT PIPES	1-2007538-5
			NO LIGHT PIPES	2007538-8
			OUTER 2 LIGHT PIPES	2007538-7
			INNER 2 LIGHT PIPES	2007538-6
			4 LIGHT PIPES	2007538-5
			NO LIGHT PIPES	2007538-4
			OUTER 2 LIGHT PIPES	2007538-3
			INNER 2 LIGHT PIPES	2007538-2
			4 LIGHT PIPES	2007538-1

THIS DRAWING IS A CONTROLLED DOCUMENT. DWN: M. SHIRK 03JAN2007
 CHK: D. SZCZESNY 03JAN2007
 APVD: D. SZCZESNY 03JAN2007

DIMENSIONS: mm
 TOLERANCES UNLESS OTHERWISE SPECIFIED:
 0 PLC ±0.10
 1 PLC ±0.10
 2 PLC ±0.10
 3 PLC ±0.10
 4 PLC ±0.10
 ANGLES ±°

MATERIAL: ¹
 FINISH: ⁴ ⁵

NAME: CAGE AND PT CONNECTOR ASSEMBLY, WITH EMI GASKET, PRESS FIT, 2X1, STACKED SFP+
 SIZE: 114-13219
 WEIGHT: -
 CUSTOMER DRAWING

TE Connectivity
 A100779C=2007538
 SCALE: 5:1 SHEET 1 OF 4 REV E

REVISIONS				
P.	LTN	DESCRIPTION	DATE	APVD
-		SEE SHEET 1	-	-

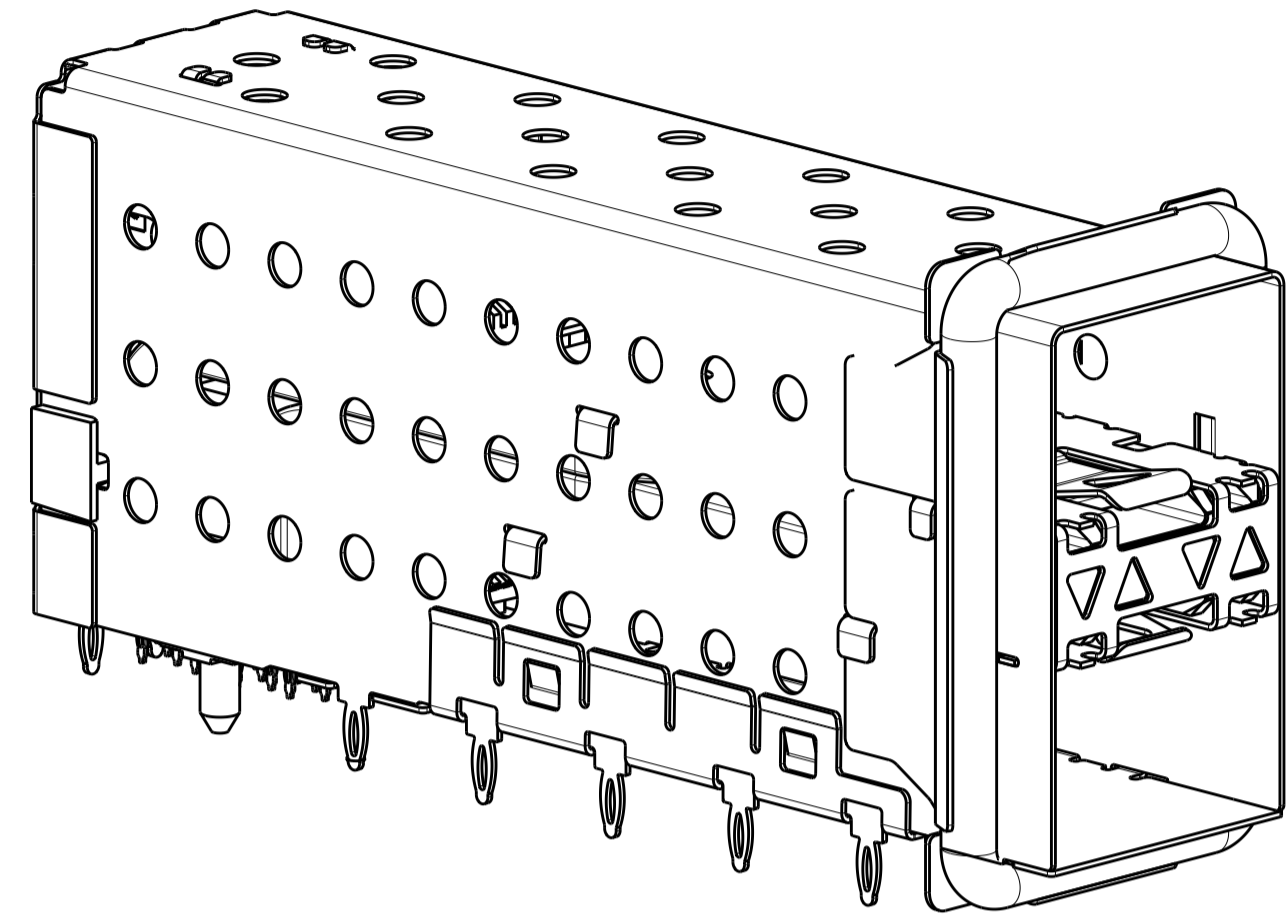

2007538-5 AND 1-2007538-5
 SCALE 3:1

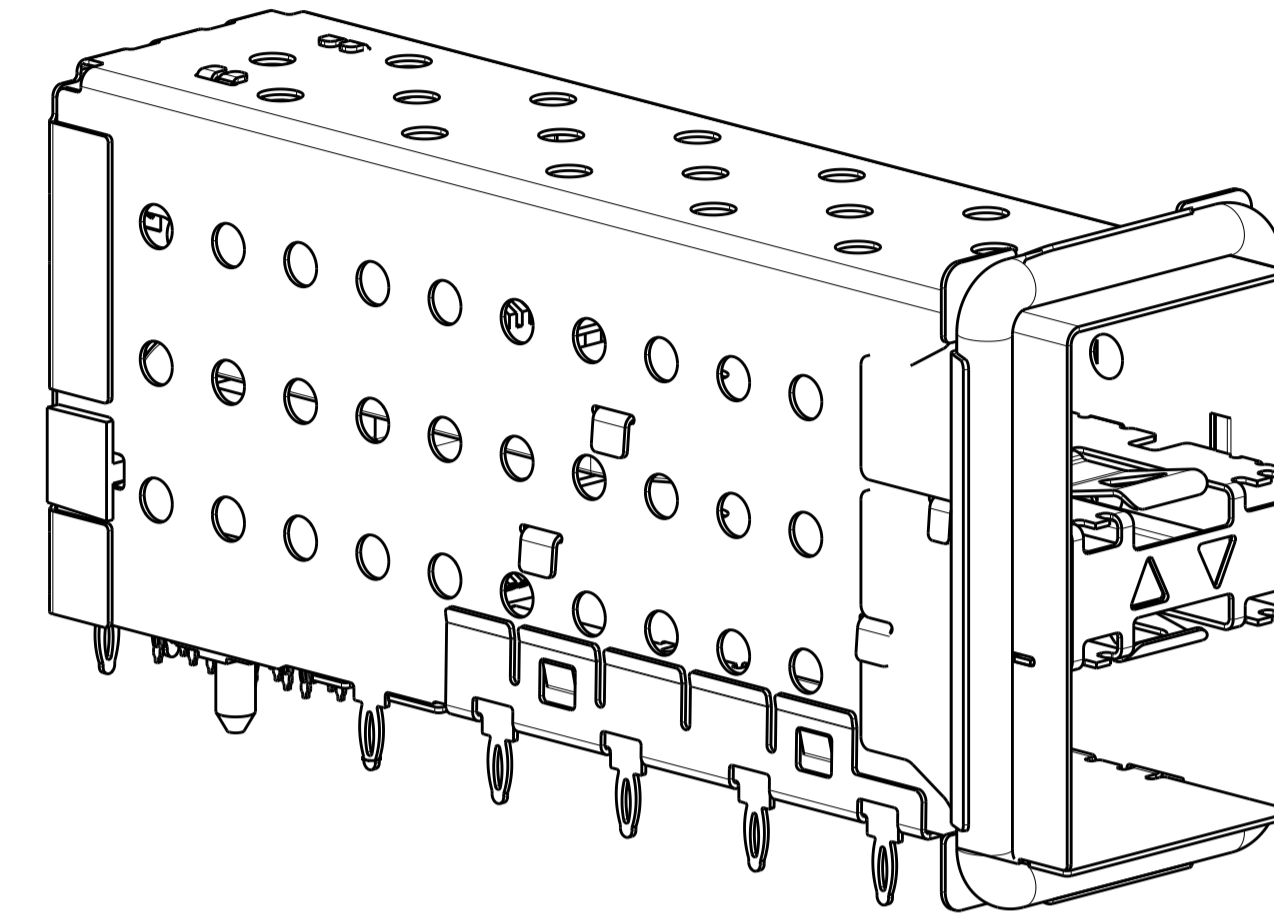

2007538-6 AND 1-2007538-6
 SCALE 3:1

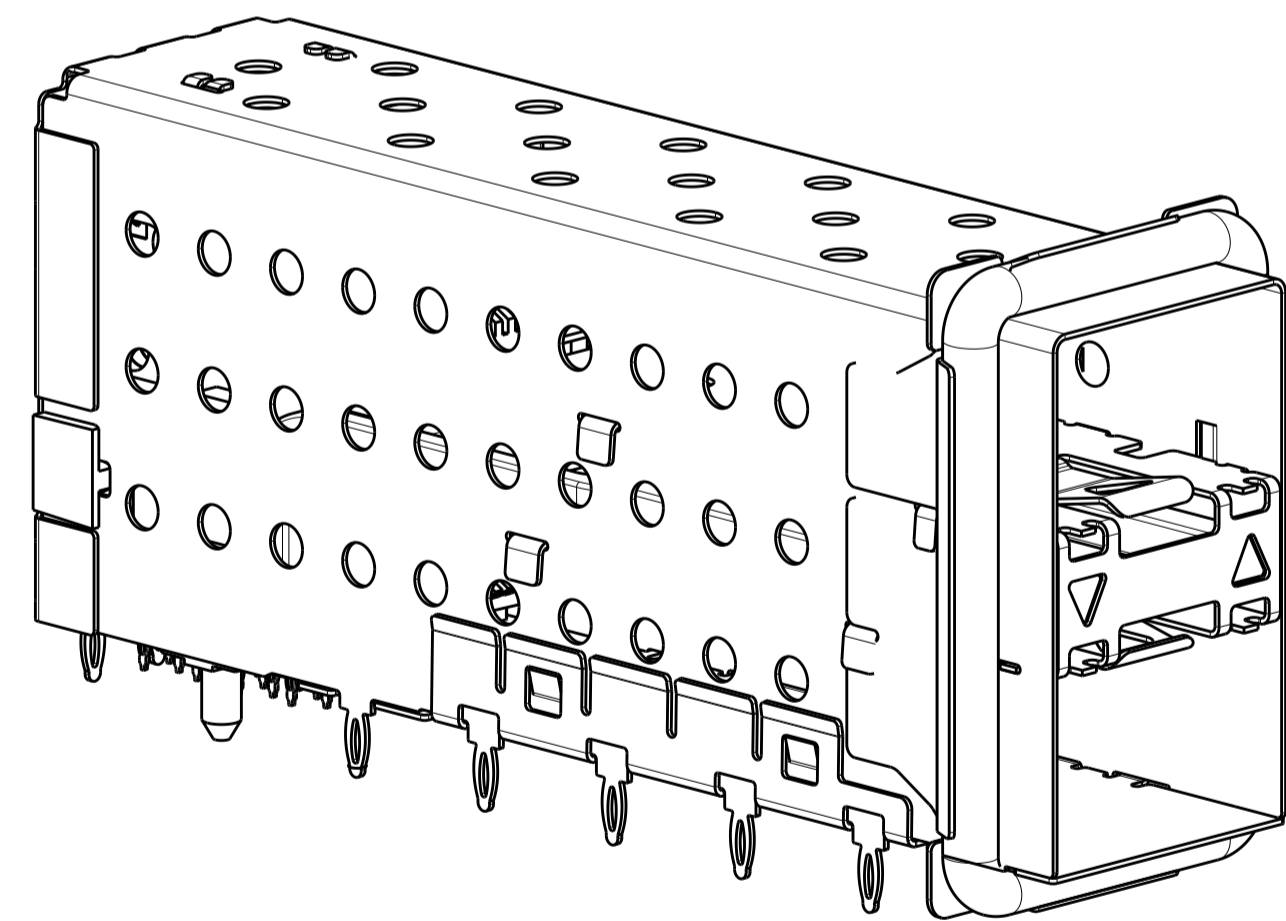

2007538-7 AND 1-2007538-7
 SCALE 3:1

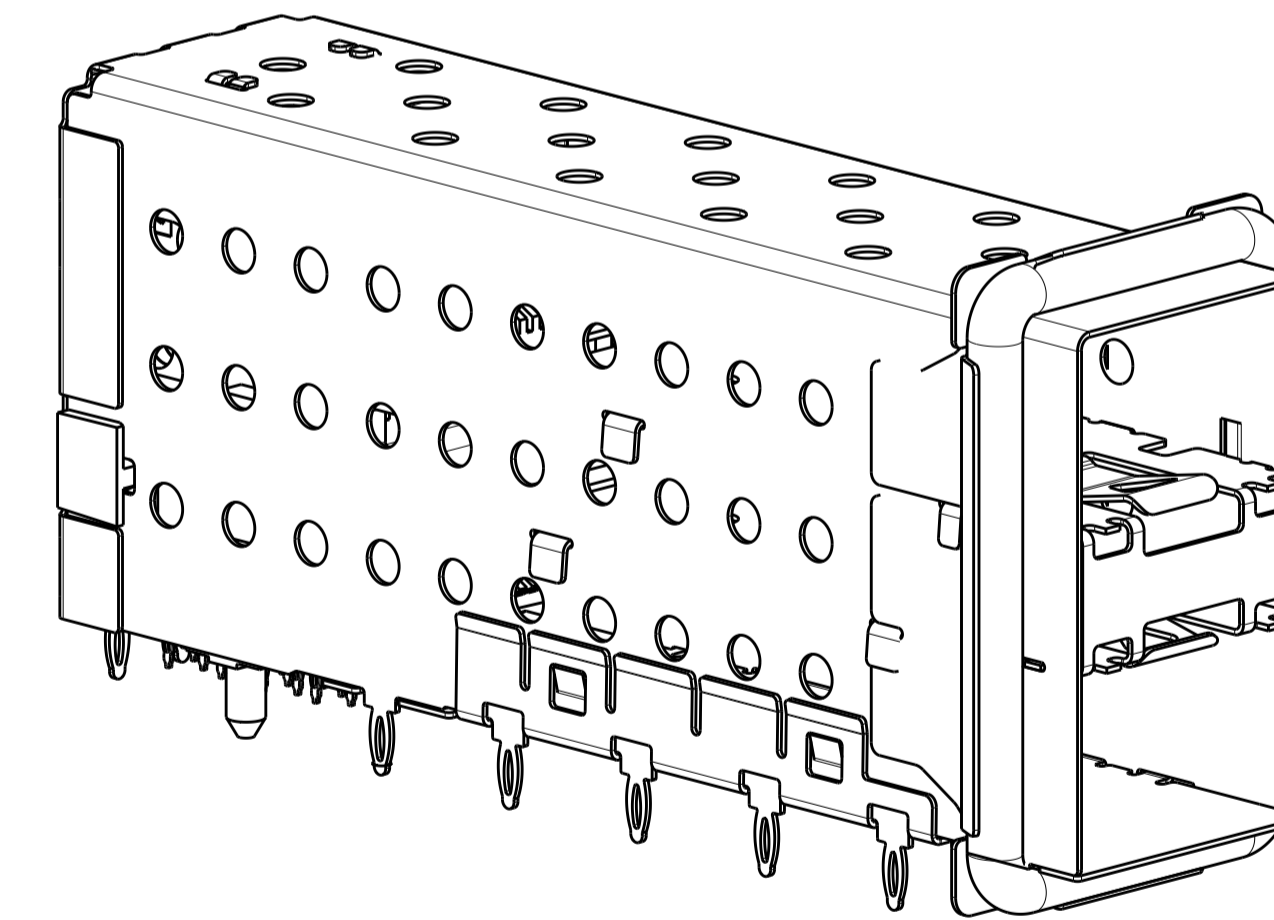

2007538-8 AND 1-2007538-8
 SCALE 3:1

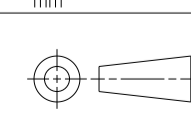
THIS DRAWING IS A CONTROLLED DOCUMENT.		DWN M. SHIRK 03JAN2007	 TE Connectivity
DIMENSIONS:		CHK D. SZCZESNY 03JAN2007	
mm	TOLERANCES UNLESS OTHERWISE SPECIFIED:	APVD D. SZCZESNY 03JAN2007	NAME CAGE AND PT CONNECTOR ASSEMBLY, WITH EMI GASKET, PRESS FIT, 2X1, STACKED SFP+
	0 PLC ±0.10 1 PLC ±0.10 2 PLC ±0.10 3 PLC ±0.10 4 PLC ±0.10 ANGLES ±°	PRODUCT SPEC 108-2331	SIZE 114-13219
MATERIAL	FINISH	APPLICATION SPEC	RESTRICTED TO
		WEIGHT	A100779C=2007538
		CUSTOMER DRAWING	SCALE 5:1 SHEET 1 OF 4 REV E

REVISIONS				
P.	LTN.	DESCRIPTION	DATE	APP'D.
-	-	SEE SHEET 1	-	-

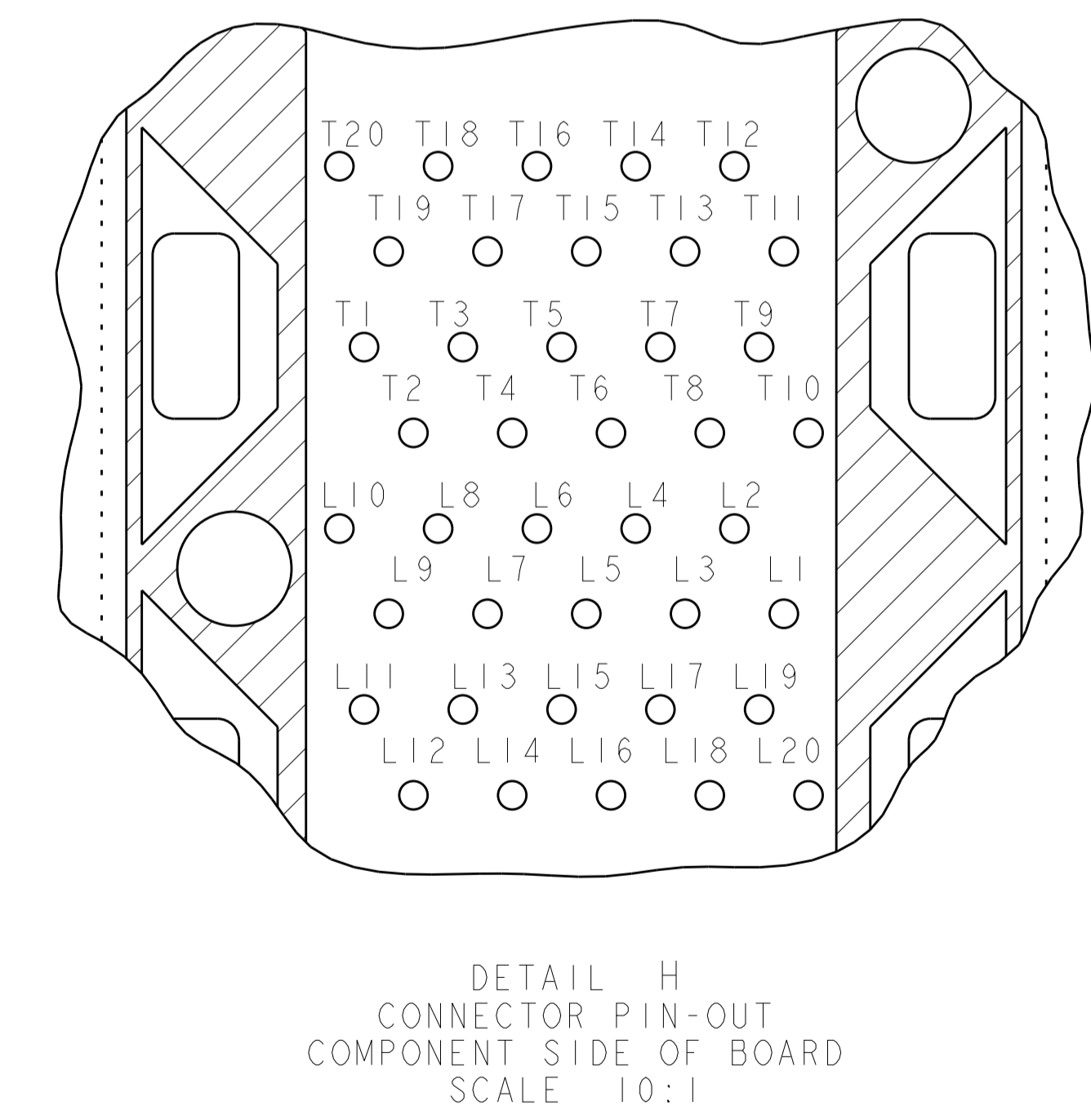
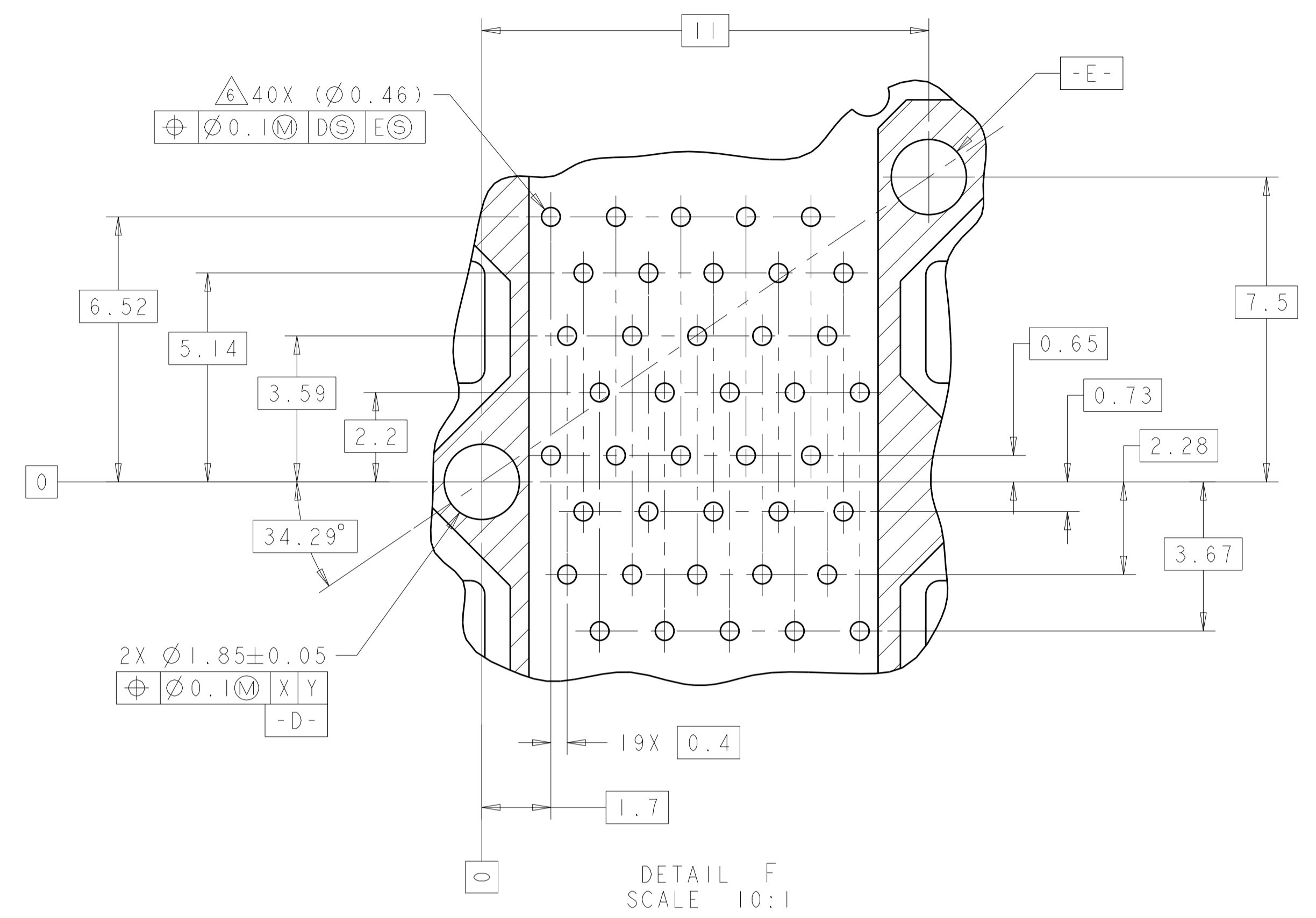
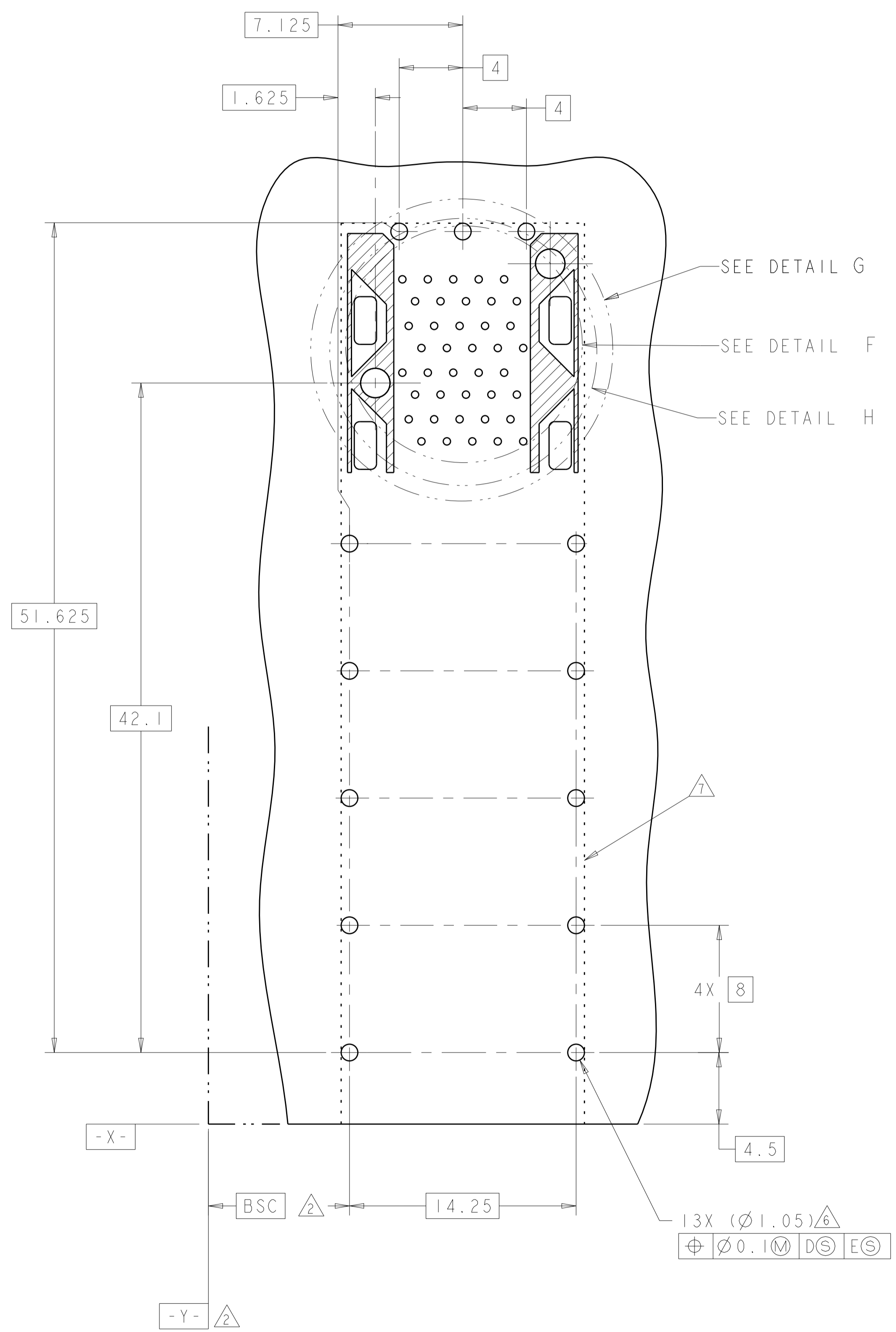

THIS DRAWING IS A CONTROLLED DOCUMENT.		OWN: M. SHIRK 03JAN2007	TE Connectivity
DIMENSIONS: mm		CHK: D. SZCZESNY 03JAN2007	
TOLERANCES UNLESS OTHERWISE SPECIFIED:		APVD: D. SZCZESNY 03JAN2007	NAME: CAGE AND PT CONNECTOR ASSEMBLY, WITH EMI GASKET, PRESS FIT, 2X1, STACKED SFP+
0 PLC ±0.10		PRODUCT SPEC: 108-2331	
1 PLC ±0.10		APPLICATION SPEC: 114-13219	SIZE: A100779 CAGE CODE: 2007538 DRAWING NO: 2007538
2 PLC ±0.10		WEIGHT: -	
3 PLC ±0.10		CUSTOMER DRAWING	SCALE: 5:1
4 PLC ±0.10			SHEET 1 OF 4
ANGLES ±°			REV E
FINISH: -			

REVISIONS				
P.	LTN.	DESCRIPTION	DATE	APP'D.
-	-	SEE SHEET 1	-	-

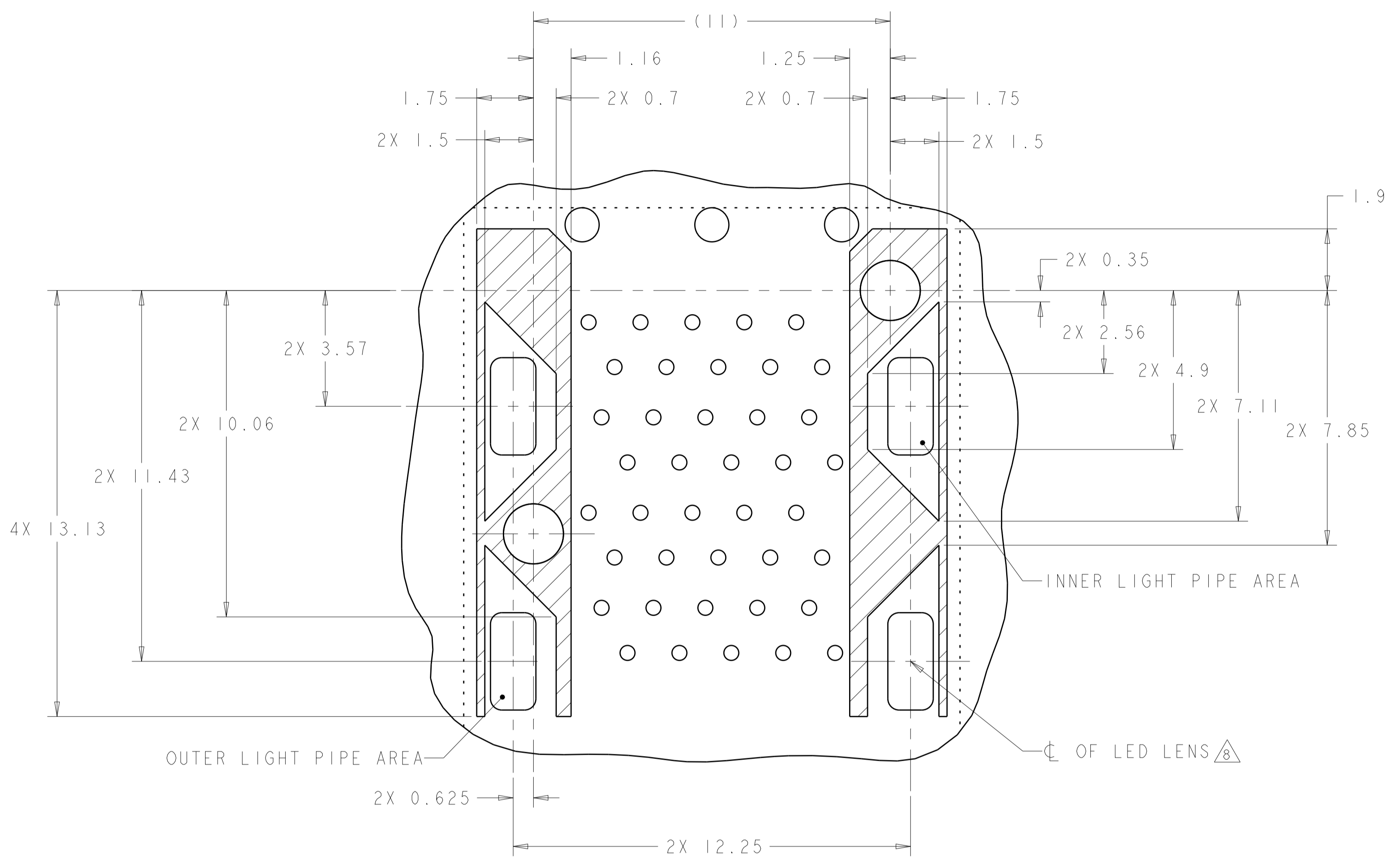

DETAIL G
CONNECTOR HOUSING
KEEPOUT ZONE
SCALE 10:1

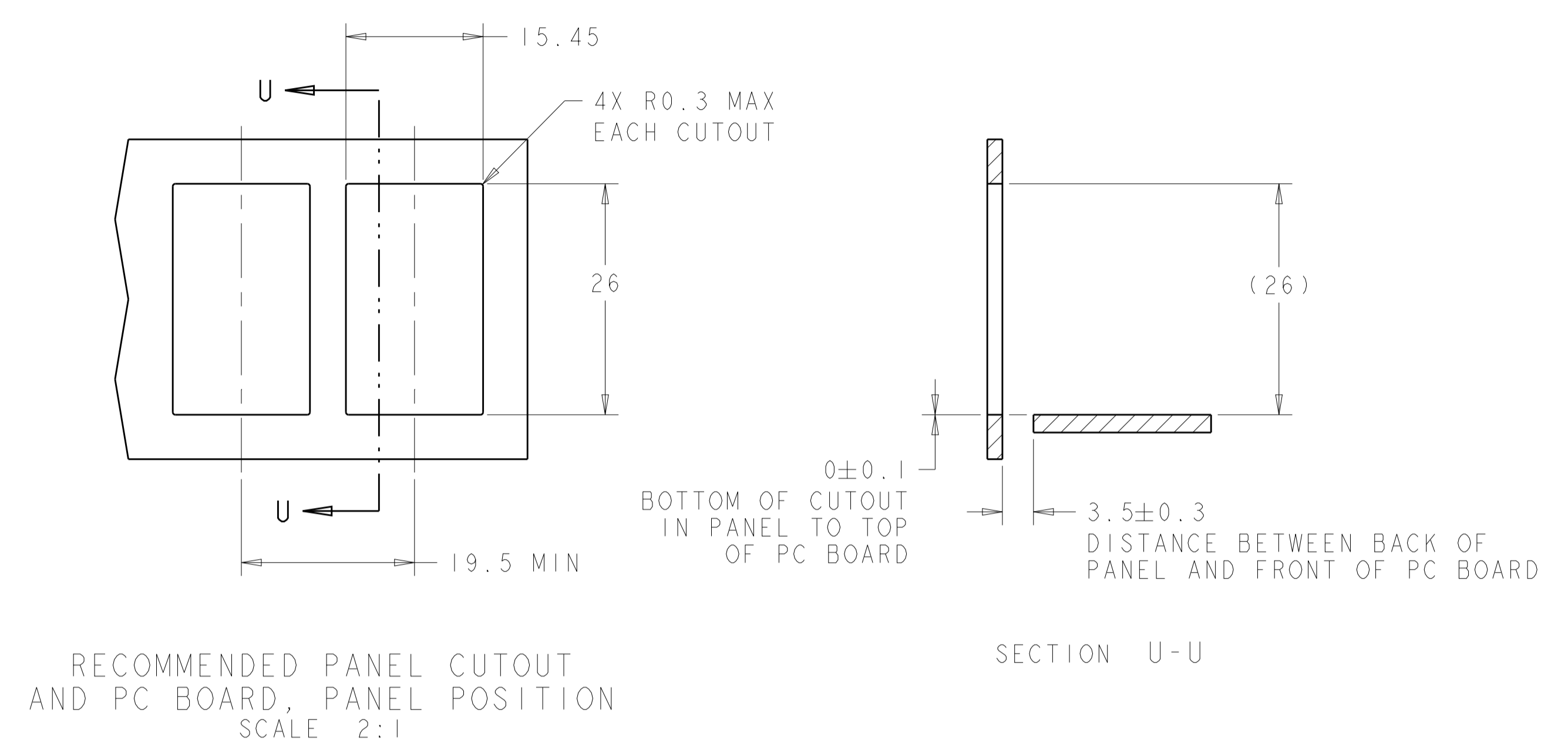

RECOMMENDED PANEL CUTOUT
AND PC BOARD, PANEL POSITION
SCALE 2:1

THIS DRAWING IS A CONTROLLED DOCUMENT.		DWN: M. SHIRK 03JAN2007 CHK: D. SZCZESNY 03JAN2007 APVD: D. SZCZESNY 03JAN2007	TE Connectivity
DIMENSIONS: mm	TOLERANCES UNLESS OTHERWISE SPECIFIED: 0 PLC ±0.10 1 PLC ±0.10 2 PLC ±0.10 3 PLC ±0.10 4 PLC ±0.10 ANGLES ±°	NAME: CAGE AND PT CONNECTOR ASSEMBLY, WITH EMI GASKET, PRESS FIT, 2X1, STACKED SFP+ PRODUCT SPEC: 108-2331 APPLICATION SPEC: 114-13219 WEIGHT: - FINISH: -	
MATERIAL:		CUSTOMER DRAWING	SIZE: A100779 CAGE CODE: C=2007538 SCALE: 5:1 SHEET 1 OF 4 REV E