

**ABSTRACT**

This user's guide provides detailed testing instructions for the BQ25180 evaluation module (EVM). Also included are descriptions of the necessary equipment, equipment setup, procedures, the printed-circuit board layouts, schematics, and the bill of materials (BOM).

Throughout this user's guide, the abbreviation *EVM*, *BQ25180EVM*, and the term evaluation module are synonymous with the BQ25180 evaluation module, unless otherwise noted.

Table of Contents

1 Introduction	3
1.1 Features.....	3
2 EVM Setup	3
3 EVM Connectors and Test Points	5
4 Testing Procedures	6
4.1 Equipment.....	6
4.2 Charge Mode.....	6
4.3 Ship Mode.....	9
5 PCB Layouts	10
6 Schematic	11
7 Bill of Materials	14
8 Revision History	17

List of Figures

Figure 4-1. BQ25180 EVM Connections.....	6
Figure 4-2. TI Charger GUI Device Selection.....	7
Figure 4-3. BQ25180EVM Connected.....	8
Figure 4-4. Quick Start.....	8
Figure 4-5. Register Map.....	9
Figure 4-6. SHIP_RST Register.....	9
Figure 5-1. Top Overlay.....	10
Figure 5-2. Top Solder.....	10
Figure 5-3. Top Layer.....	10
Figure 5-4. Bottom Layer.....	10
Figure 5-5. Bottom Solder.....	10
Figure 5-6. Bottom Overlay.....	10
Figure 6-1. BQ25180EVM Schematic.....	11
Figure 6-2. BQ25180EVM Jumper Connectors.....	12
Figure 6-3. LDO for Other Peripherals.....	13

List of Tables

Table 2-1. Jumper Descriptions.....	3
Table 2-2. Recommended Operating Conditions.....	4
Table 3-1. Factory Jumper Settings.....	5
Table 7-1. Bill of Materials.....	14

Trademarks

All trademarks are the property of their respective owners.



WARNING

Hot surface! Contact may cause burns. Do not touch!

Some components may reach high temperatures $>55^{\circ}\text{C}$ when the board is powered on. The user must not touch the board at any point during operation or immediately after operating, as high temperatures may be present.

1 Introduction

The BQ25180EVM is an evaluation kit for the BQ25180 integrated battery charge management IC. The BQ25180 is an integrated battery charge management IC that integrates the most common functions for wearable devices: linear charger, regulated output, manual reset with timer, and ship mode function.

1.1 Features

This EVM has the following features:

- 1-A Linear battery charger
- I2C Configurable Battery Regulation voltage with 0.5% Accuracy
- Configurable Termination Current down to 0.5 mA
- Programmable thermal charging profile with configurable Hot, Warm, Cool, and Cold thresholds
- Power Path Management for powering the system and charging the battery
- 15-nA shutdown mode for longest shelf life
- One Button Wake-up and Reset Input with Adjustable Timers
- I2C Communication control

See the device datasheet for detailed features and operation of the integrated IC

2 EVM Setup

[Table 2-1](#) lists the jumper connections and the jumper description. [Table 2-2](#) lists the recommended operating conditions.

Table 2-1. Jumper Descriptions

Jumper Name	Description
J1	Provides the I2C Pins a pull-up to 3p3V
J2	VIN and GND connector. Input voltage from external power supply. Recommended voltage is 5V and OVP is 5.7V. Max input voltage is 25V while in OVP
J3	VBAT and GND connector. Battery connection using jumper for easy access
J4	Battery Pack Connector. Battery connection using JST header
J5	TS potentiometer connector. Connects TS potentiometer to TS pin. Leaving this jumper open will leave the TS pin open.
J6	USB2ANY connector. For connecting the device to the USB2ANY evaluation board to allow computer to interface with the EVM
J7	VIO connector to 3p3V
J8, J9	Board Connector to the other module
J10	/INT connector to 3p3V
J11	I2C Pull-up
J14	Mirco-USB connector (optional for VIN) BQ25180EVM Connections

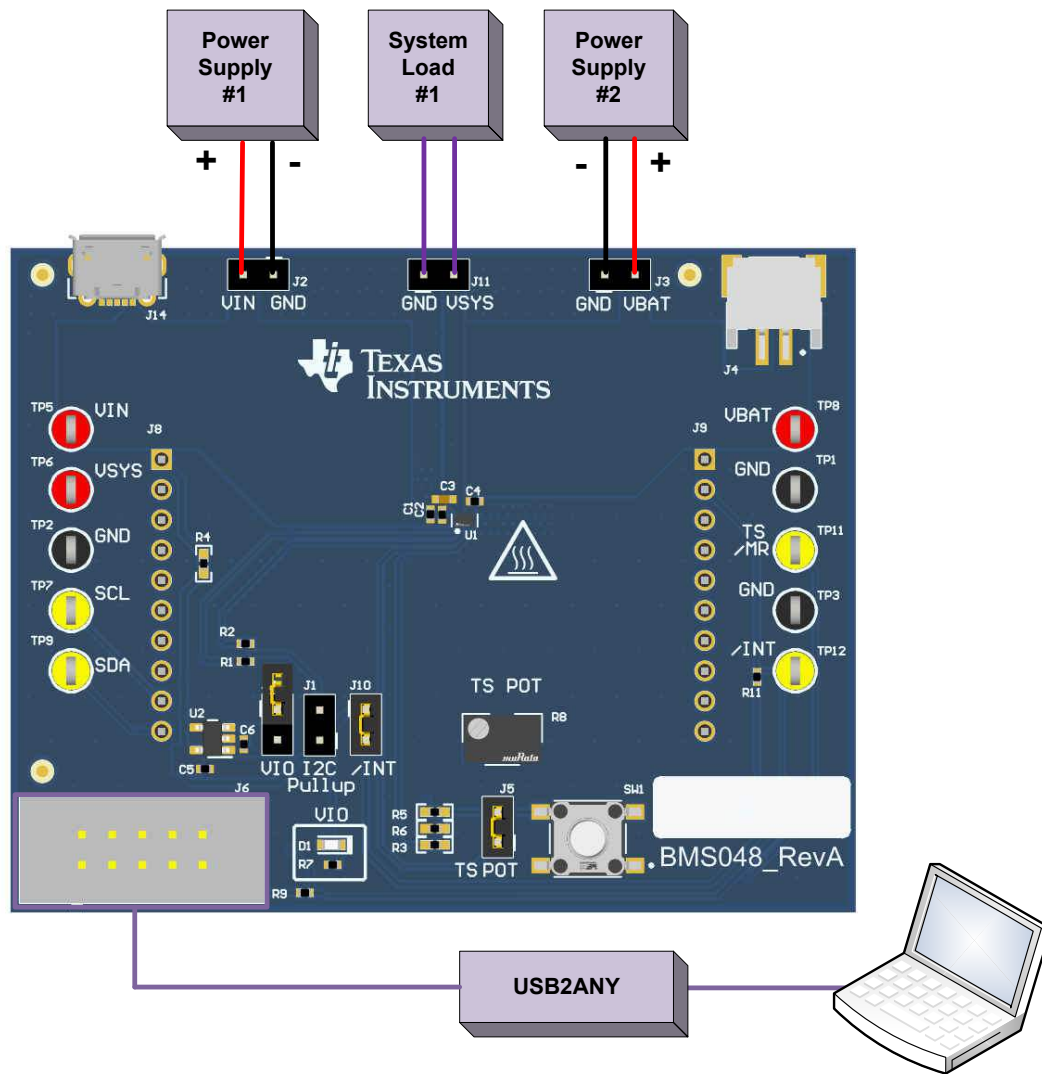

Table 2-2. Recommended Operating Conditions

		MIN	NOM	MAX	UNIT
VBAT	Battery Voltage Range	2.2		4.6	V
VIN	Input Voltage Range	2.7		5.5	V
IIN	Input Current Range (IN to SYS)			1.1	A
IBAT	Battery Discharge Current (BAT to SYS)			1.5	A
TA	Operating Ambient Temperature Range	-40		85	°C
TJ	Operating Junction Temperature Range	-40		125	°C

3 EVM Connectors and Test Points

Table 3-1 shows the default configuration for connectors.

Table 3-1. Factory Jumper Settings

Jumper Name	Description	Setting
J1	I2C Pullup	NA
J2	VIN and GND connector	NA
J3	VBAT and GND connector	NA
J4	Battery Pack Connector	NA
J5	TS Potentiometer Connector	Connected
J6	USB2ANY Connector	NA
J7	VIO Connector to 3p3V.	NA
J8, J9	Board connector to other modules	NA
J10	/INT connector to 3p3V	Connect 3p3V to /INT
J11	VSYS and GND connector	NA
J14	Micro USB connector (optional for VIN)	NA

Note

Connecting the J7 jumper will enable the VIO LED. This LED will draw 10mA.

4 Testing Procedures

4.1 Equipment

This section includes a list of supplies required to perform tests on this EVM

1. *Two Power Supplies:* Keithley 2400 Powersupply or equivalent
 - a. Power Supply #1 (PS #1) will be used as input voltage
 - b. Power Supply #2 (PS #2) will be used as battery voltage
2. *4 Channel Oscilloscope:* To monitor voltages at VIN, VBAT, and VSYS
 - a. Channel 1 (SC #1) will be used to probe VIN
 - b. Channel 2 (SC #2) will be used to probe VBAT
 - c. Channel 3 (SC #3) will be used to probe VSYS
3. *Computer:* A computer with at least one USB port and a USB cable
4. *PC communication interface:* [USB2ANY](#) with the latest firmware
5. *Software:* Download the [TI Charger GUI](#) from Texas Instruments.

4.2 Charge Mode

Connect the equipment as the following:

- Power Supply PS#1: VIN of the BQ25180 at 5V
- Power supply PS#2: VBAT of the BQ25180 at 3.7V
- Scope Channel SC#1: VIN
- Scope Channel SC#2: VSYS
- Scope Channel SC#3: VBAT

Turn ON the supply PS#2, then turn ON the supply PS#1. The VSYS will rise to the level of 4.5V. The device will begin to charge as long as the TS is left at default configuration and there are no other faults.

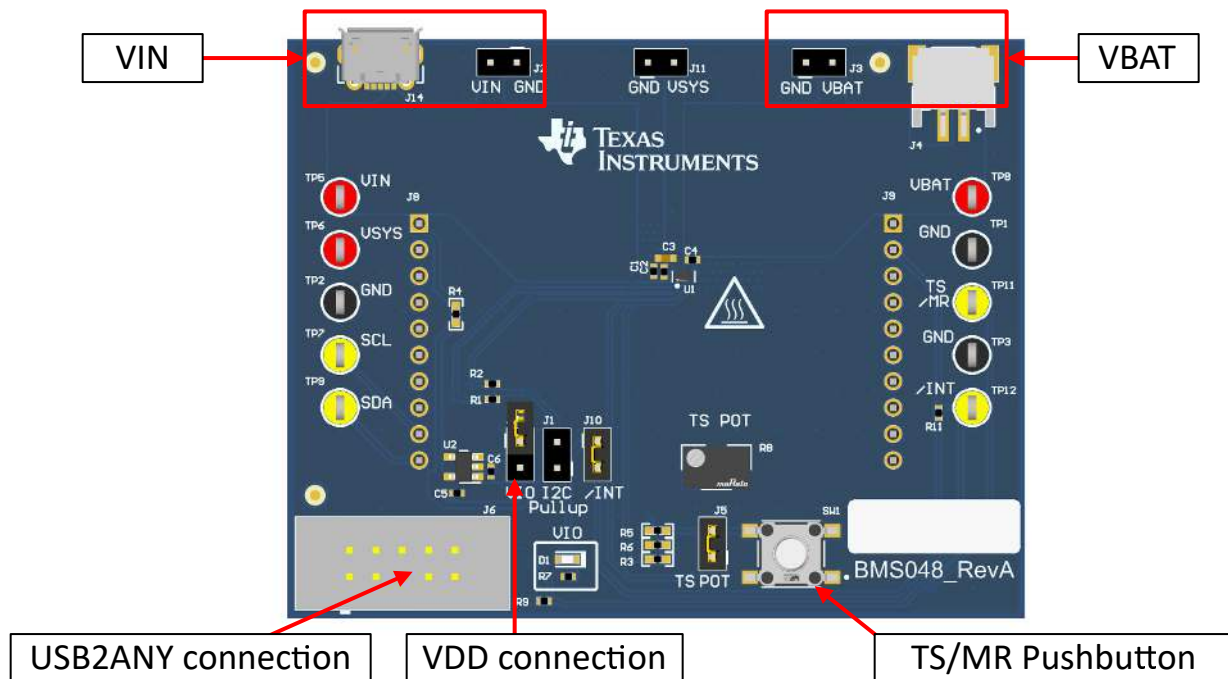

Figure 4-1. BQ25180 EVM Connections

To adjust the charge current or change other parameters, connect the USB2ANY to the EVM and then startup TI Charger GUI.

Note

If the supplies (VIN and VBAT) are turned off, you will need to restart the TI Charger GUI for correct I²C transactions to be reflected in the TI Charger GUI

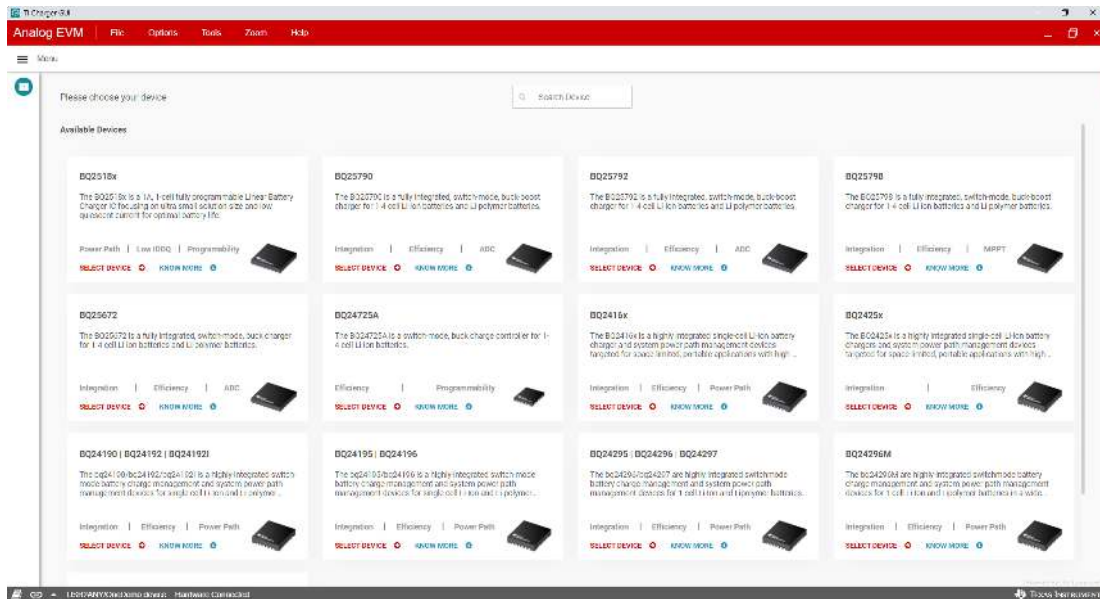

Figure 4-2. TI Charger GUI Device Selection

Select the BQ2518X from the charger selection. Click *Quick Start* or *Register Map*.

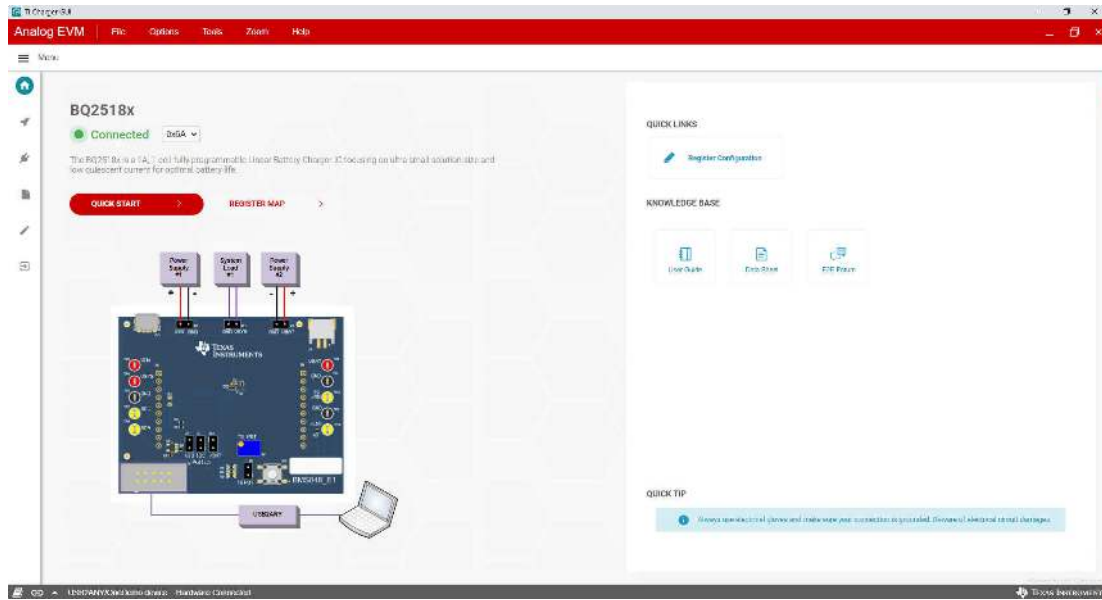

Figure 4-3. BQ25180EVM Connected

The Quick Start is shown in [Figure 4-4](#)

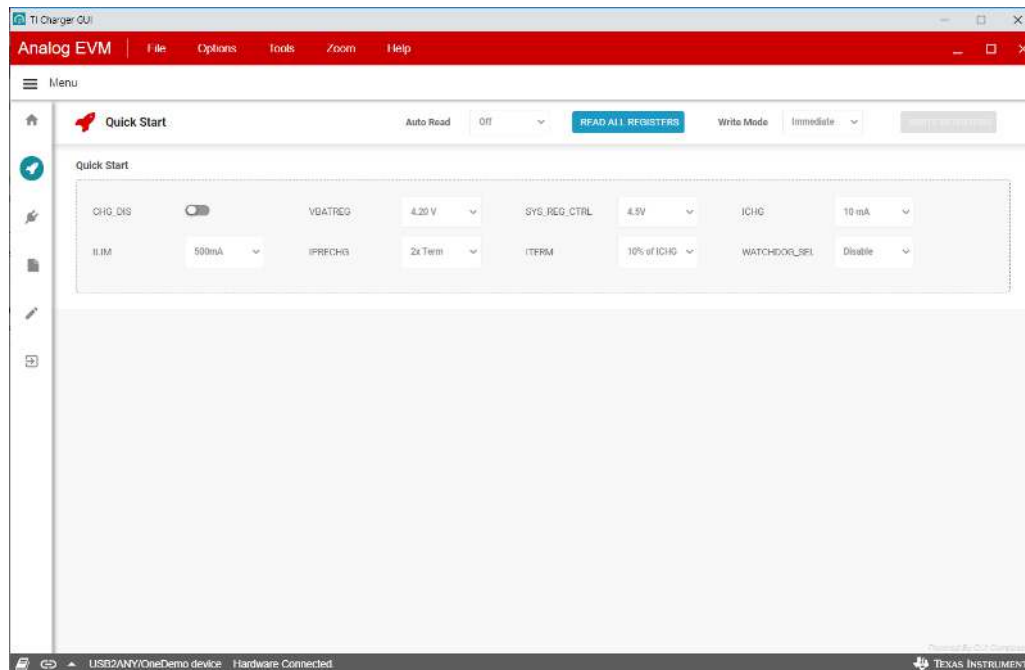

Figure 4-4. Quick Start

The register map is shown in Figure 4-5.

Register Name	Address	Value	Bits								
			7	6	5	4	3	2	1	0	
BQ2518x											
STAT0	0x00	0x01	0	0	0	0	0	0	0	0	1
STAT1	0x01	0x40	0	1	-	0	0	0	0	0	0
FLAG0	0x02	0x00	0	0	0	0	0	0	0	0	0
VBAT_CTRL	0x03	0x46	-	1	0	0	0	0	1	1	0
ICHG_CTRL	0x04	0x05	0	0	0	0	0	0	1	0	1
CHARGECTRL0	0x05	0x2C	-	0	1	0	1	0	1	0	0
CHARGECTRL1	0x06	0x56	0	1	0	1	0	1	1	0	0
IC_CTRL	0x07	0x87	1	0	0	0	0	0	1	1	1
TMR_ILIM	0x08	0x4D	0	1	0	0	1	1	0	1	1
SHIP_RST	0x09	0x11	0	0	0	1	0	0	0	0	1
SYS_REG	0x0A	0x40	0	1	0	-	0	0	0	0	0
TS_CONTROL	0x0B	0x00	0	0	0	0	0	0	0	0	0
MASK_ID	0x0C	0xC0	1	1	0	0	0	0	0	0	0

Figure 4-5. Register Map

4.3 Ship Mode

To go to Ship Mode, enable ship mode through an I²C transaction to set EN_SHIP_RST bits or the PB_LPRESS_ACTION bits as shown in Figure 4-6:

- EN_RST_SHIP = 2b01 (Enable shipmode with wake on button press or adapter insert)
- PB_PRESS_ACTION = 2b10 (Enable shipmode)

Enter ship mode by removing VIN if setting EN_RST_SHIP to 2b01. If setting PB_LPRESS_ACTION to 2b10 to enable shipmode, hold the TS/MR button for the configured t_{LPRESS} then remove VIN.

You will know you are in Ship Mode as the voltage on the SYS (SC#2) will fall to 0 V.

Figure 4-6. SHIP_RST Register

5 PCB Layouts

Figure 5-1 through Figure 5-6 show the EVM PCB layout images.

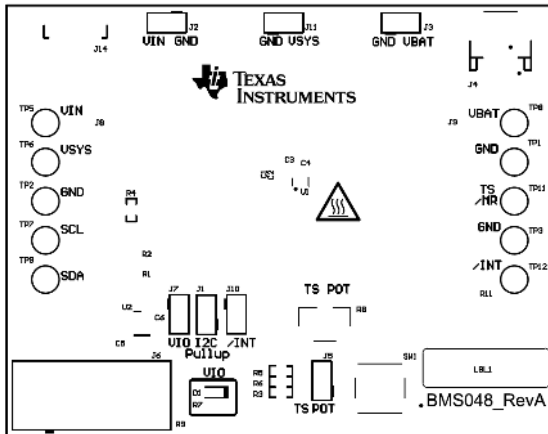

Figure 5-1. Top Overlay

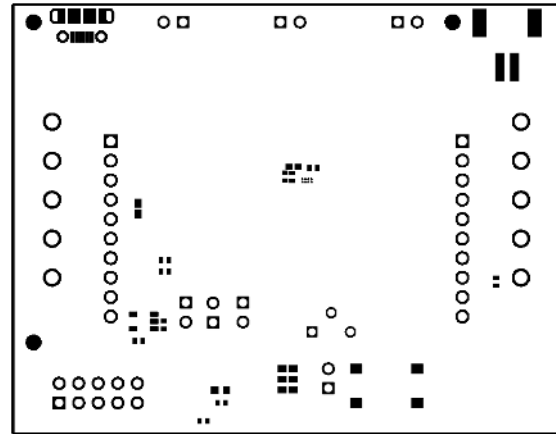

Figure 5-2. Top Solder

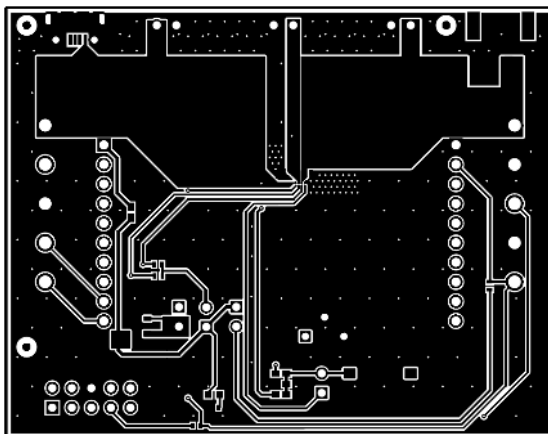

Figure 5-3. Top Layer

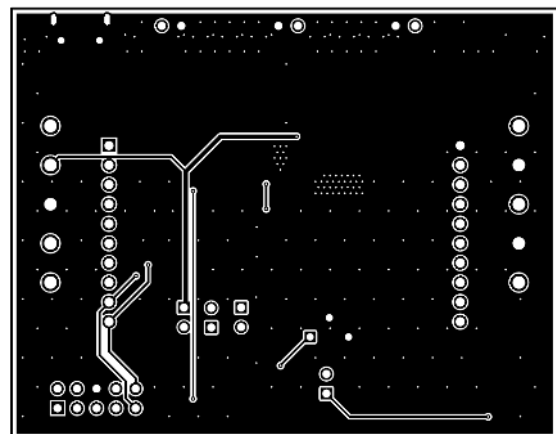

Figure 5-4. Bottom Layer

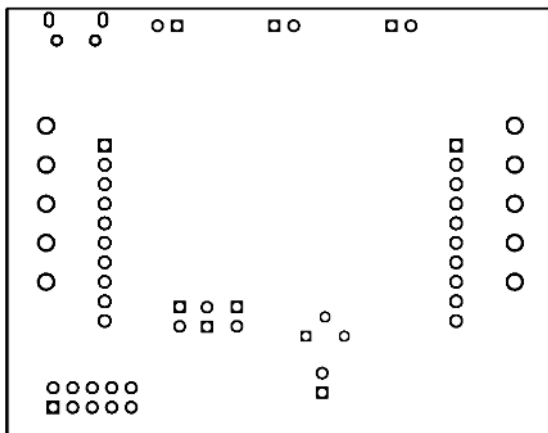

Figure 5-5. Bottom Solder

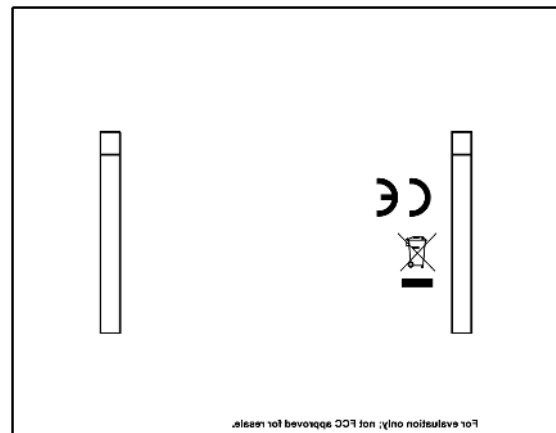

Figure 5-6. Bottom Overlay

6 Schematic

Figure 6-1 illustrates the EVM schematic.

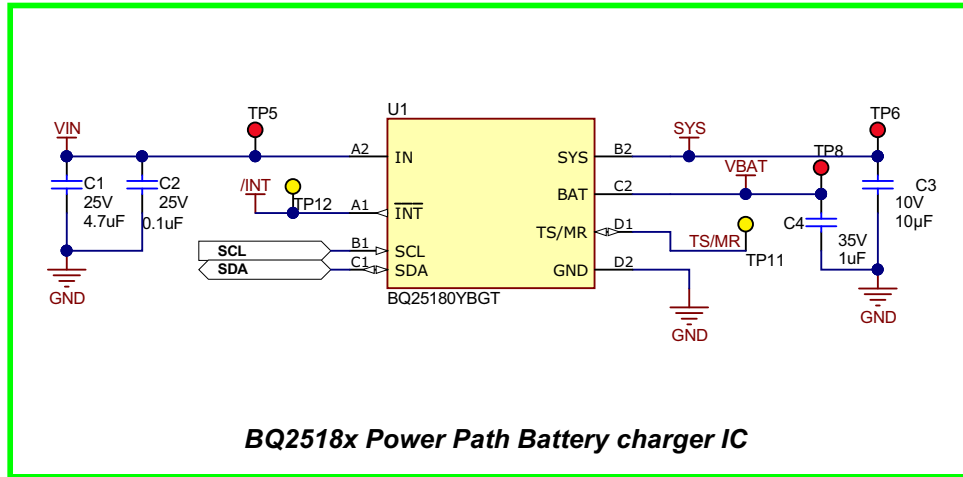

Figure 6-1. BQ25180EVM Schematic

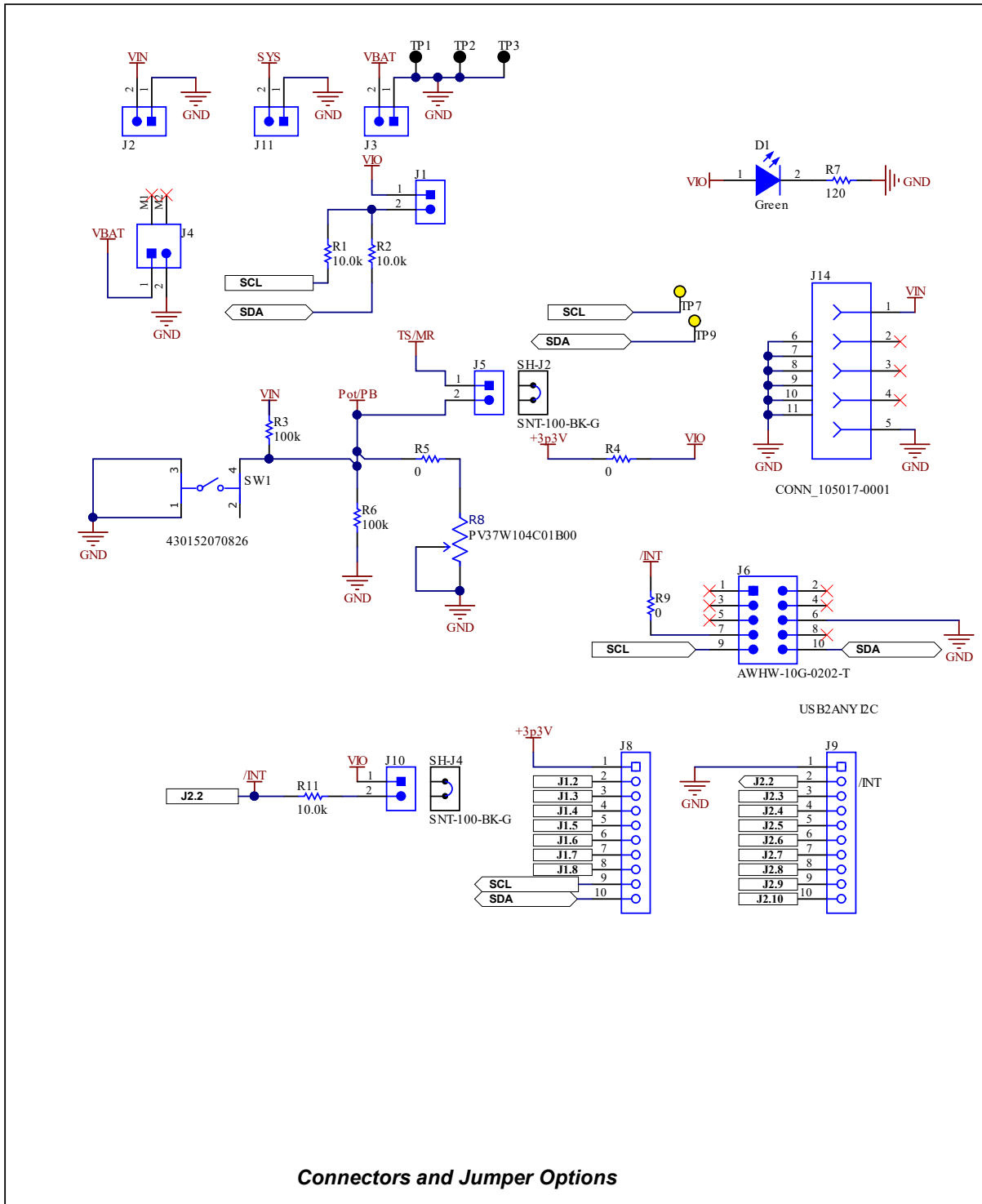

Figure 6-2. BQ25180EVM Jumper Connectors

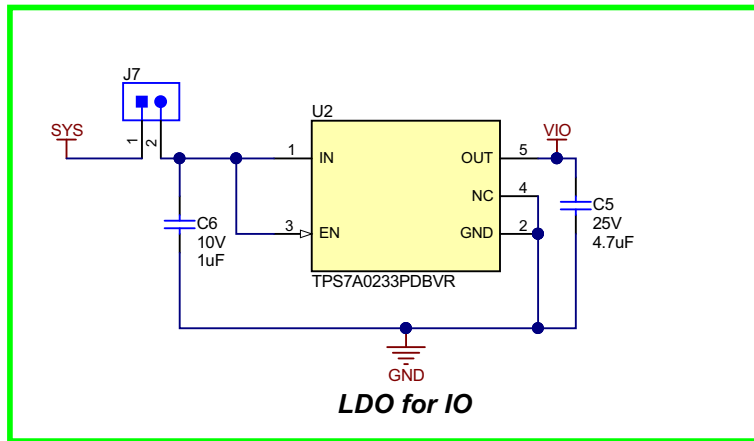

Figure 6-3. LDO for Other Peripherals

7 Bill of Materials

Table 7-1 lists the EVM bill of materials (BOM).

Table 7-1. Bill of Materials

Designator	Quantity	Value	Description	Package Reference	PartNumber	Manufacturer
!PCB1	1		Printed Circuit Board		BMS048	Any
C1, C5	2	2.2uF	CAP, CERM, 2.2 uF, 25 V, +/- 10%, X5R, 0402	0402	GRM155R61E225KE11D	MuRata
C2	1	0.1uF	CAP, CERM, 0.1 uF, 25 V, +/- 10%, X5R, 0402	0402	GRM155R61E104KA87D	MuRata
C3	1	10uF	CAP, CERM, 10 uF, 10 V, +/- 20%, X5R, 0402	0402	CL05A106MP8NUB8	Samsung Electro-Mechanics
C4	1	1uF	CAP, CERM, 1 uF, 35 V, +/- 10%, JB, 0402	0402	C1005JB1V105K050BC	TDK
C6	1	1uF	CAP, CERM, 1 uF, 10 V, +/- 10%, X5R, 0402	0402	GRM155R61A105KE15D	MuRata
D1	1	Green	LED, Green, SMD	1.6x0.8x0.8mm	LTST-C190GKT	Lite-On
J1, J2, J3, J5, J7, J10, J11	7		Header, 100mil, 2x1, Tin, TH	Header, 2 PIN, 100mil, Tin	PEC02SAAN	Sullins Connector Solutions
J4	1		Header (shrouded), 2mm, 2x1, R/A, SMT	Header, 2x1, 2mm, R/A	S2B-PH-SM4-TB(LF)(SN)	JST Manufacturing
J6	1		Header(Shrouded), 2.54mm, 5x2, Gold, TH	Header, 2.54mm, 5x2, TH	AWHW-10G-0202-T	Assman WSW
J8, J9	2		Connector, Receptacle, 100mil, 10x1, Gold plated, TH	10x1 Receptacle	SSW-110-23-F-S	Samtec
J14	1		Connector, Receptacle, Micro-USB Type B, R/A, Bottom Mount SMT	Micro USB receptacle	105017-0001	Molex
LBL1	1		Thermal Transfer Printable Labels, 0.650" W x 0.200" H - 10,000 per roll	PCB Label 0.650 x 0.200 inch	THT-14-423-10	Brady
R1, R2, R11	3	10.0k	RES, 10.0 k, 1%, 0.063 W, 0402	0402	RC0402FR-0710KL	Yageo America

Table 7-1. Bill of Materials (continued)

Designator	Quantity	Value	Description	Package Reference	PartNumber	Manufacturer
R5	1	0	RES, 0, 5%, 0.1 W, AEC-Q200 Grade 0, 0402	0402	ERJ-2GE0R00X	Panasonic
R6	1	100k	RES, 100 k, 1%, 0.0625 W, AEC-Q200 Grade 0, 0402	0402	AC0402FR-07100KL	Yageo America
R7	1	120	RES, 120, 5%, 0.063 W, 0402	0402	CRCW0402120RJNED	Vishay-Dale
R8	1	100kΩ	12-Turn Through Hole Trimmer Resistor with Pin Terminations, 10% 1/4W 150ppm/C	PTH_POT_6MM4_4MM0	PV37W104C01B00	Murata
R9	1	0	RES, 0, 5%, 0.063 W, AEC-Q200 Grade 0, 0402	0402	CRCW04020000Z0ED	Vishay-Dale
SH-J2, SH-J3, SH-J4	3	1x2	Shunt, 100mil, Gold plated, Black	Shunt	SNT-100-BK-G	Samtec
SW1	1		Tactile Switch SPST-NO Top Actuated Surface Mount	SMT_TACT	430152070826	Würth Electronics
TP1, TP2, TP3	3		Test Point, Multipurpose, Black, TH	Black Multipurpose Testpoint	5011	Keystone
TP5, TP6, TP8	3		Test Point, Multipurpose, Red, TH	Red Multipurpose Testpoint	5010	Keystone
TP7, TP9, TP11, TP12	4		Test Point, Multipurpose, Yellow, TH	Yellow Multipurpose Testpoint	5014	Keystone
U1	1		1-Cell I2C/Standalone Linear Charger with Power Path, Regulated System Output and Push-Button Controller	DSBGA8	BQ25180YBGT	Texas Instruments
U2	1		1-uA IQ, 200-mA, Ultralow IQ Low-Dropout Regulator, DBV0005A (SOT-23-5)	DBV0005A	TPS7A0233PDBVR	Texas Instruments
FID1, FID2, FID3	0		Fiducial mark. There is nothing to buy or mount.	N/A	N/A	N/A

Table 7-1. Bill of Materials (continued)

Designator	Quantity	Value	Description	Package Reference	PartNumber	Manufacturer
R3	0	100k	RES, 100 k, 1%, 0.0625 W, AEC-Q200 Grade 0, 0402	0402	AC0402FR-07100KL	Yageo America
R4	0	0	RES, 0, 5%, 0.1 W, AEC-Q200 Grade 0, 0402	0402	ERJ-2GE0R00X	Panasonic

8 Revision History

NOTE: Page numbers for previous revisions may differ from page numbers in the current version.

Changes from Revision A (January 2022) to Revision B (February 2022)	Page
• Added Hot Surface Warning.....	3

Changes from Revision * (August 2021) to Revision A (January 2022)	Page
• Production release of EVM user's guide.....	1

IMPORTANT NOTICE AND DISCLAIMER

TI PROVIDES TECHNICAL AND RELIABILITY DATA (INCLUDING DATA SHEETS), DESIGN RESOURCES (INCLUDING REFERENCE DESIGNS), APPLICATION OR OTHER DESIGN ADVICE, WEB TOOLS, SAFETY INFORMATION, AND OTHER RESOURCES "AS IS" AND WITH ALL FAULTS, AND DISCLAIMS ALL WARRANTIES, EXPRESS AND IMPLIED, INCLUDING WITHOUT LIMITATION ANY IMPLIED WARRANTIES OF MERCHANTABILITY, FITNESS FOR A PARTICULAR PURPOSE OR NON-INFRINGEMENT OF THIRD PARTY INTELLECTUAL PROPERTY RIGHTS.

These resources are intended for skilled developers designing with TI products. You are solely responsible for (1) selecting the appropriate TI products for your application, (2) designing, validating and testing your application, and (3) ensuring your application meets applicable standards, and any other safety, security, regulatory or other requirements.

These resources are subject to change without notice. TI grants you permission to use these resources only for development of an application that uses the TI products described in the resource. Other reproduction and display of these resources is prohibited. No license is granted to any other TI intellectual property right or to any third party intellectual property right. TI disclaims responsibility for, and you will fully indemnify TI and its representatives against, any claims, damages, costs, losses, and liabilities arising out of your use of these resources.

TI's products are provided subject to [TI's Terms of Sale](#) or other applicable terms available either on ti.com or provided in conjunction with such TI products. TI's provision of these resources does not expand or otherwise alter TI's applicable warranties or warranty disclaimers for TI products.

TI objects to and rejects any additional or different terms you may have proposed.

Mailing Address: Texas Instruments, Post Office Box 655303, Dallas, Texas 75265
Copyright © 2022, Texas Instruments Incorporated