

## FEATURES

- 5 V at 55 mA output for an HDMI +5 V requirement
- For hot plug detect with HDMI Tx
- 3.3 V at 60 mA output
- Lithium battery input: 2.5 V to 4.5 V
- Short-circuit limitation: 100 mA
- 3 × 4 array WLCSP package
- Package footprint: 3 mm<sup>2</sup> (2 mm × 1.5 mm)
- Package height: 0.5 mm

## APPLICATIONS

- Cellular phones with HDMI/DVI output
- Companion chip with HDMI Tx
- Portable media players (PMPs)
- Mobile Internet devices
- Digital still cameras

## GENERAL DESCRIPTION

The AD9394 uses charge pump technology to provide the power required to drive 55 mA of 5 V for HDMI interface requirements.

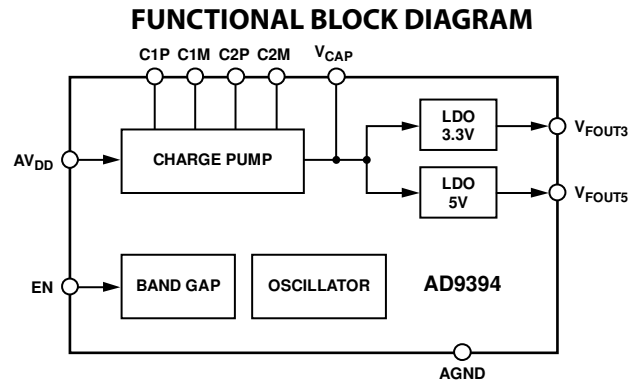

Figure 1.

### Rev. B

Information furnished by Analog Devices is believed to be accurate and reliable. However, no responsibility is assumed by Analog Devices for its use, nor for any infringements of patents or other rights of third parties that may result from its use. Specifications subject to change without notice. No license is granted by implication or otherwise under any patent or patent rights of Analog Devices. Trademarks and registered trademarks are the property of their respective owners.

## TABLE OF CONTENTS

Features .....	1	Pin Configuration and Function Descriptions.....	5
Applications.....	1	Typical Performance Characteristics .....	6
General Description .....	1	Application Schematic .....	7
Functional Block Diagram .....	1	Outline Dimensions .....	8
Revision History .....	2	Ordering Guide .....	8
Specifications.....	3		
Absolute Maximum Ratings.....	4		
Thermal Characteristics .....	4		
ESD Caution.....	4		

## REVISION HISTORY

### 10/11—Rev. A to Rev. B

Changes to Table 1.....	3
Added Typical Performance Characteristics Section and Figure 3; Renumbered Figures Consecutively.....	6
Changes to Detail A Dimensions, Figure 6; Updated Outline Dimensions .....	8

### 6/10—Rev. 0 to Rev. A

Changes to Supply Current Parameter and Short-Circuit Load Current Parameter, Added Maximum Load Current Parameter, Table 1.....	3
--	---

### 1/10—Revision 0: Initial Version

## SPECIFICATIONS

Table 1.

Parameter	Min	Typ	Max	Unit	Test Conditions/Comments
INPUT VOLTAGE, $AV_{DD}$	2.5		4.5	V	
Enable Pin (EN), $V_{IH}$	1.4		$AV_{DD}$	V	
Enable Pin (EN), $V_{IL}$	-0.4		+0.4	V	
SUPPLY CURRENT					
$I_{AVDD}$		$1 \times I_{LDO3} + 2 \times I_{LDO5}$	$1.1 \times \text{typ}$	mA	$AV_{DD} > 4.1 \text{ V}$
		$2 \times I_{LDO3} + 2 \times I_{LDO5}$	$1.1 \times \text{typ}$	mA	$3.4 \text{ V} < AV_{DD} \leq 4.1 \text{ V}$
		$2 \times I_{LDO3} + 3 \times I_{LDO5}$	$1.1 \times \text{typ}$	mA	$AV_{DD} \leq 3.4 \text{ V}$
		60	66	mA	$I_{LDO3} = 60 \text{ mA}, AV_{DD} > 4.1 \text{ V}$
		120	132	mA	$I_{LDO3} = 60 \text{ mA}, AV_{DD} \leq 4.1 \text{ V}$
		110	121	mA	$I_{LDO5} = 55 \text{ mA}, AV_{DD} > 3.4 \text{ V}$
		165	182	mA	$I_{LDO5} = 55 \text{ mA}, AV_{DD} \leq 3.4 \text{ V}$
$I_{AVDD}$ , No Load			1	mA	$AV_{DD} = 4.5 \text{ V}, \text{EN high}, I_{LDO3} = 0 \text{ mA}, I_{LDO5} = 0 \text{ mA}$
MAXIMUM LOAD CURRENT					
$V_{FOUT5}$ Load Compliance	4.8	5.0	5.2	V	55 mA load
$V_{FOUT3}$ Load Compliance <sup>1</sup>	3.0	3.3	3.6	V	60 mA load
SHUTDOWN CURRENT			2	$\mu\text{A}$	EN low
$V_{FOUT5}$ Ripple			50	mV	
$V_{FOUT3}$ Ripple			50	mV	
LDO3 Shutdown of LDO5 <sup>1</sup>	10		20	mA	
SHORT-CIRCUIT LOAD CURRENT					
LDO5			100	mA	Shorted LDO5 draws $\leq 100 \text{ mA}$ from $AV_{DD}$
LDO3			>500	mA	No short-circuit limit for LDO3
LDO5 REVERSE VOLTAGE			7.5	V	$AV_{DD} = 0 \text{ V}$ , voltage applied to $V_{FOUT5}$ pin
START-UP TIME			1	ms	Time from EN high to stable output voltage

<sup>1</sup> LDO3 current in excess of 10 mA may shut down the LDO5 output.

## ABSOLUTE MAXIMUM RATINGS

$T_A = 25^\circ\text{C}$ , unless otherwise noted.

Table 2.

Parameter	Rating
Supply Voltage, $V_{DD}$	5.0 V
Operating Temperature Range	$-40^\circ\text{C}$ to $+85^\circ\text{C}$
Storage Temperature Range	$-65^\circ\text{C}$ to $+150^\circ\text{C}$
Junction Temperature	$150^\circ\text{C}$
Power Dissipation	0.7 W

Stresses above those listed under Absolute Maximum Ratings may cause permanent damage to the device. This is a stress rating only; functional operation of the device at these or any other conditions above those indicated in the operational section of this specification is not implied. Exposure to absolute maximum rating conditions for extended periods may affect device reliability.

## THERMAL CHARACTERISTICS

Table 3. Thermal Resistance

Package Type	$\theta_{JA}$	Unit
$3 \times 4$ Array WLCSP Package	65	$^\circ\text{C}/\text{W}$

## ESD CAUTION



**ESD (electrostatic discharge) sensitive device.** Charged devices and circuit boards can discharge without detection. Although this product features patented or proprietary protection circuitry, damage may occur on devices subjected to high energy ESD. Therefore, proper ESD precautions should be taken to avoid performance degradation or loss of functionality.

## PIN CONFIGURATION AND FUNCTION DESCRIPTIONS

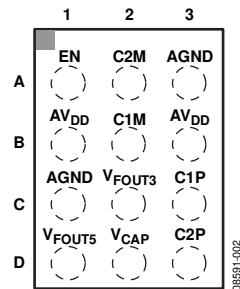

**AD9394**  
TOP VIEW  
(BALL SIDE DOWN)  
Not to Scale

Figure 2. Pin Configuration

Table 4. Pin Function Descriptions

Pin No.	Mnemonic	Description
A1	EN	Enable Part. When EN = 1, the part is on.
A2	C2M	Flying Capacitor. Connect with a 1 $\mu$ F capacitor to C2P (Pin D3).
A3	AGND	Ground.
B1	AV <sub>DD</sub>	Input Voltage from Battery.
B2	C1M	Flying Capacitor. Connect with a 1 $\mu$ F capacitor to C1P (Pin C3).
B3	AV <sub>DD</sub>	Input Voltage from Battery.
C1	AGND	Ground.
C2	V <sub>FOUT3</sub>	3.3 V Output. Connect with a 1 $\mu$ F capacitor to AGND.
C3	C1P	Flying Capacitor Connection.
D1	V <sub>FOUT5</sub>	5 V Output. Connect with a 1 $\mu$ F capacitor to AGND.
D2	V <sub>CAP</sub>	Charge Pump Output Voltage (~5.6 V). Connect with a 2.2 $\mu$ F capacitor to AGND.
D3	C2P	Flying Capacitor Connection.

### TYPICAL PERFORMANCE CHARACTERISTICS

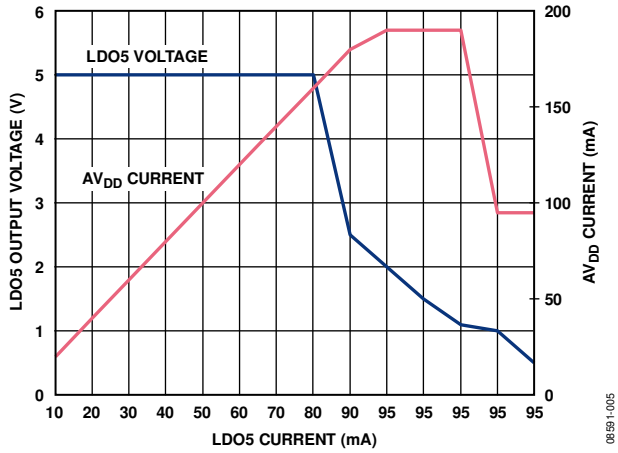

Figure 3. LDO5 Voltage vs. Current

APPLICATION SCHEMATIC

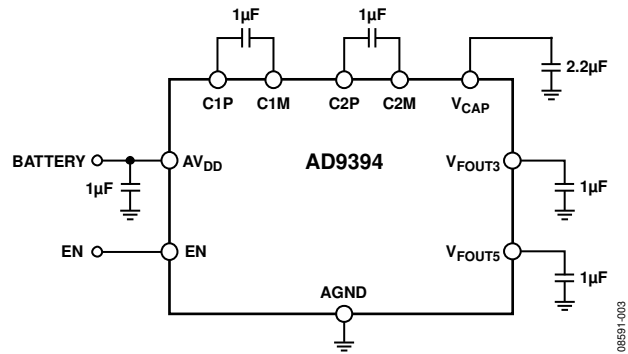

Figure 4. Application Schematic

OUTLINE DIMENSIONS

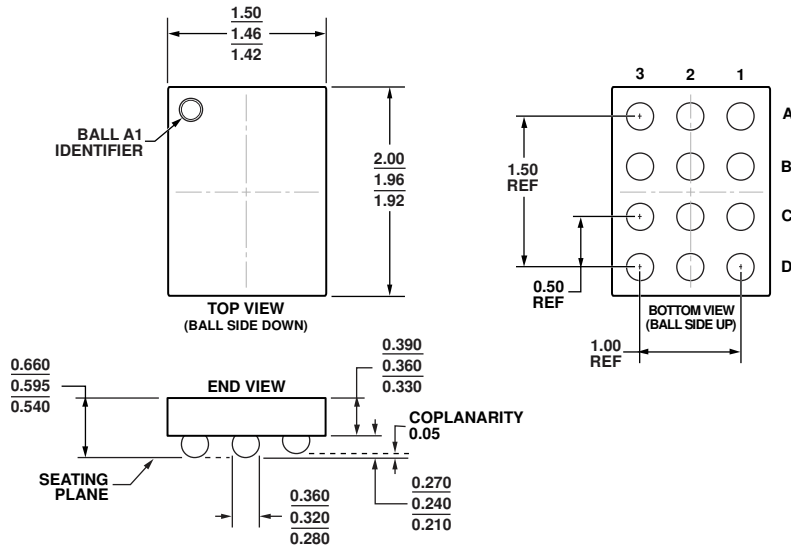

Figure 5. 12-Ball Wafer Level Chip Scale Package [WLCSP]  
1.5 mm x 2.0 mm Body  
(CB-12-2)  
Dimensions shown in millimeters

06-25-2010-B

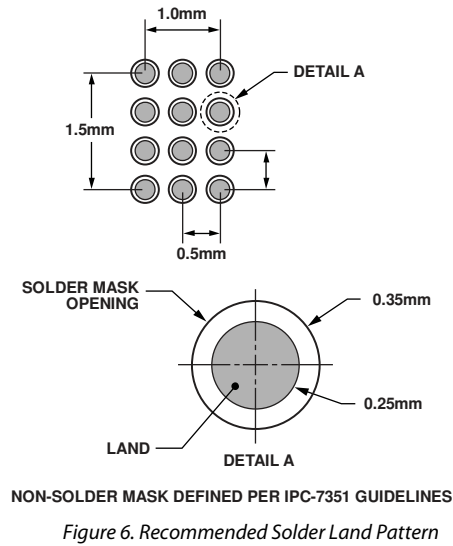

Figure 6. Recommended Solder Land Pattern

06591-004

ORDERING GUIDE

Model <sup>1</sup>	Temperature Range	Package Description	Package Option	Branding
AD9394BCBZ-R7	-40°C to +85°C	12-Ball WLCSP	CB-12-2	L8V
EVAL-AD9394Z		Evaluation Board		

<sup>1</sup> Z = RoHS Compliant Part.