

N-Channel Enhancement Mode Power MOSFET

Description

The G25N06K uses advanced trench technology to provide excellent $R_{DS(ON)}$, low gate charge. It can be used in a wide variety of applications.

General Features

- V_{DS} 60V
- I_D (at $V_{GS} = 10V$) 25A
- $R_{DS(ON)}$ (at $V_{GS} = 10V$) < 27m Ω
- $R_{DS(ON)}$ (at $V_{GS} = 4.5V$) < 35m Ω
- 100% Avalanche Tested
- RoHS Compliant

Application

- Power switch
- DC/DC converters

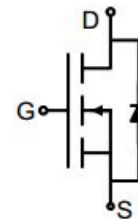

Schematic diagram

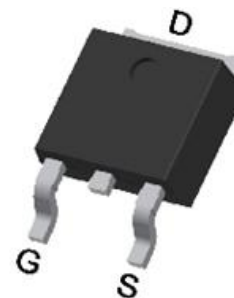

TO-252

Ordering Information

| Device | Package | Marking | Packaging |
|---------|---------|---------|--------------|
| G25N06K | TO-252 | G25N06 | 2500pcs/Reel |

Absolute Maximum Ratings $T_C = 25^\circ\text{C}$, unless otherwise noted

| Parameter | Symbol | Value | Unit |
|--|----------------|------------|------------------|
| Drain-Source Voltage | V_{DS} | 60 | V |
| Continuous Drain Current | I_D | 25 | A |
| Pulsed Drain Current (note1) | I_{DM} | 100 | A |
| Gate-Source Voltage | V_{GS} | ± 20 | V |
| Power Dissipation | P_D | 41 | W |
| Single pulse avalanche energy (note2) | E_{AS} | 30 | mJ |
| Operating Junction and Storage Temperature Range | T_J, T_{stg} | -55 To 150 | $^\circ\text{C}$ |

Thermal Resistance

| Parameter | Symbol | Value | Unit |
|---|------------|-------|--------------------|
| Thermal Resistance, Junction-to-Ambient | R_{thJA} | 60 | $^\circ\text{C/W}$ |
| Maximum Junction-to-Case | R_{thJC} | 3 | $^\circ\text{C/W}$ |

| Specifications $T_J = 25^\circ\text{C}$, unless otherwise noted | | | | | | |
|--|---------------|--|-------|------|-----------|------------|
| Parameter | Symbol | Test Conditions | Value | | | Unit |
| | | | Min. | Typ. | Max. | |
| Static Parameters | | | | | | |
| Drain-Source Breakdown Voltage | $V_{(BR)DSS}$ | $V_{GS} = 0V, I_D = 250\mu A$ | 60 | -- | -- | V |
| Zero Gate Voltage Drain Current | I_{DSS} | $V_{DS} = 60V, V_{GS} = 0V$ | -- | -- | 1 | μA |
| Gate-Source Leakage | I_{GSS} | $V_{GS} = \pm 20V$ | -- | -- | ± 100 | nA |
| Gate-Source Threshold Voltage | $V_{GS(th)}$ | $V_{DS} = V_{GS}, I_D = 250\mu A$ | 1.0 | 1.5 | 2.0 | V |
| Drain-Source On-Resistance | $R_{DS(on)}$ | $V_{GS} = 10V, I_D = 20A$ | -- | 22 | 27 | m Ω |
| | | $V_{GS} = 4.5V, I_D = 10A$ | -- | 24 | 35 | |
| Forward Transconductance | g_{FS} | $V_{GS} = 5V, I_D = 20A$ | -- | 30 | -- | S |
| Dynamic Parameters | | | | | | |
| Input Capacitance | C_{iss} | $V_{GS} = 0V,$ $V_{DS} = 30V,$ $f = 1.0\text{MHz}$ | -- | 1550 | -- | pF |
| Output Capacitance | C_{oss} | | -- | 77 | -- | |
| Reverse Transfer Capacitance | C_{rss} | | -- | 67 | -- | |
| Total Gate Charge | Q_g | $V_{DD} = 30V,$ $I_D = 20A,$ $V_{GS} = 10V$ | -- | 25 | -- | nC |
| Gate-Source Charge | Q_{gs} | | -- | 4.5 | -- | |
| Gate-Drain Charge | Q_{gd} | | -- | 6.5 | -- | |
| Turn-on Delay Time | $t_{d(on)}$ | $V_{DD} = 30V,$ $I_D = 20A,$ $R_G = 3\Omega$ | -- | 7 | -- | ns |
| Turn-on Rise Time | t_r | | -- | 20 | -- | |
| Turn-off Delay Time | $t_{d(off)}$ | | -- | 16 | -- | |
| Turn-off Fall Time | t_f | | -- | 23 | -- | |
| Drain-Source Body Diode Characteristics | | | | | | |
| Continuous Body Diode Current | I_S | $T_C = 25^\circ\text{C}$ | -- | -- | 25 | A |
| Body Diode Voltage | V_{SD} | $T_J = 25^\circ\text{C}, I_{SD} = 20A, V_{GS} = 0V$ | -- | -- | 1.2 | V |
| Reverse Recovery Charge | Q_{rr} | $I_F = 20A, V_{GS} = 0V$ $di/dt = 100A/\mu s$ | -- | 49 | -- | nC |
| Reverse Recovery Time | T_{rr} | | -- | 29 | -- | ns |

Notes

1. Repetitive Rating: Pulse width limited by maximum junction temperature
2. EAS condition : $T_J = 25^\circ\text{C}, V_{DD} = 50V, V_{GS} = 10V, L = 0.5\text{mH}, R_G = 25\Omega$
3. Identical low side and high side switch with identical R_G

Gate Charge Test Circuit

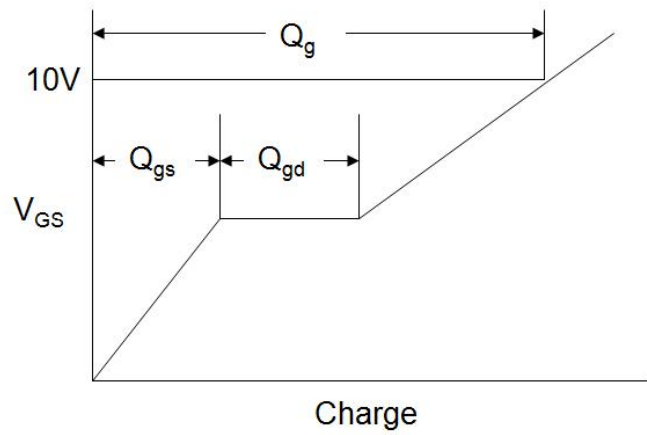
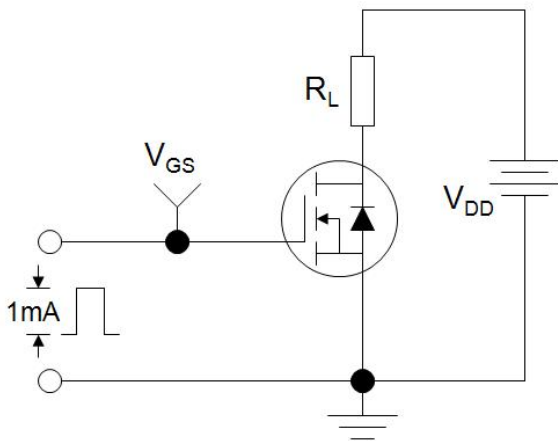

Switch Time Test Circuit

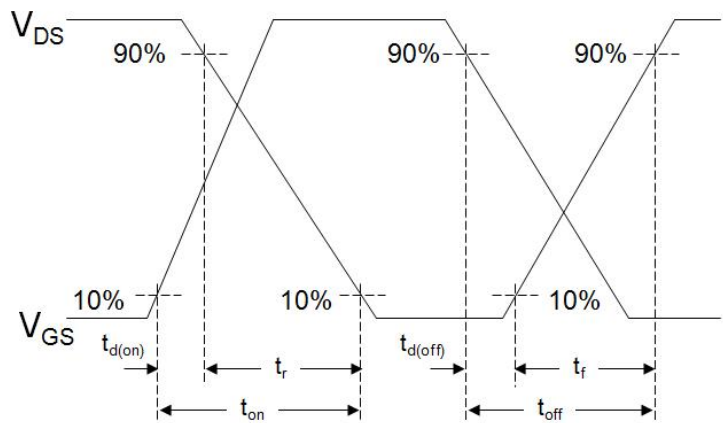
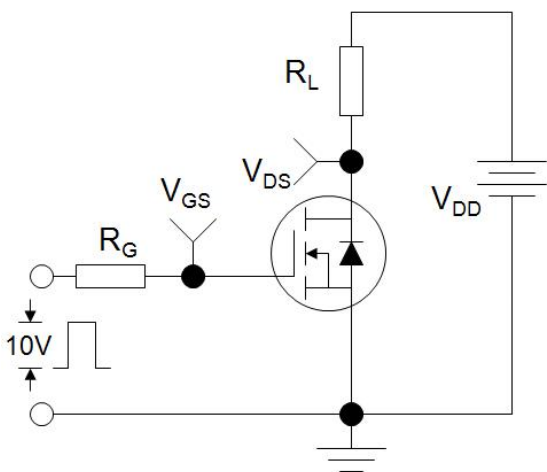

EAS Test Circuit

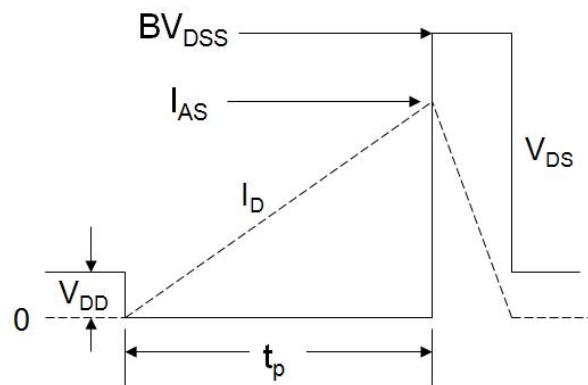
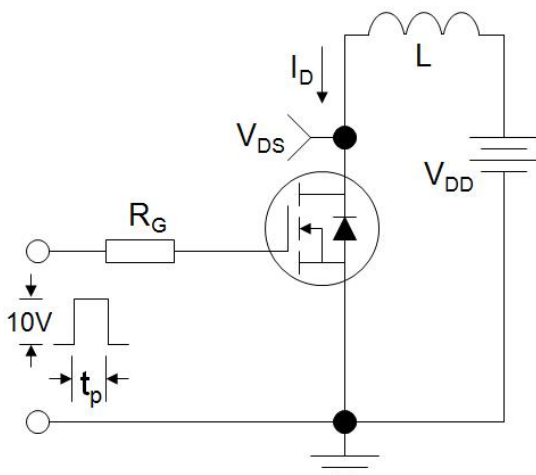

Typical Characteristics $T_J = 25^\circ\text{C}$, unless otherwise noted

Figure 1. Output Characteristics

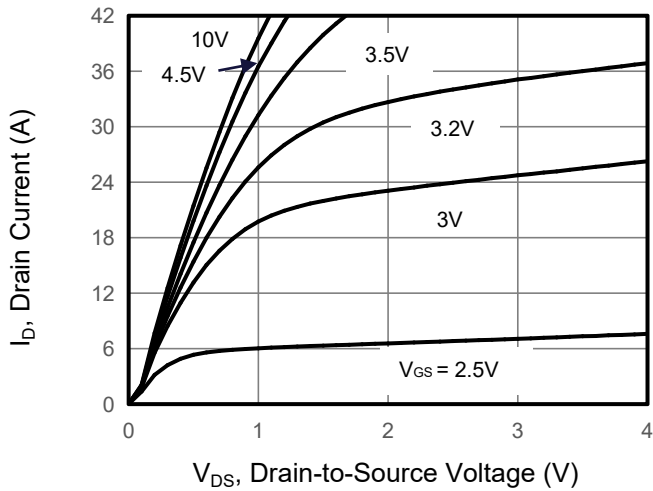

Figure 2. Transfer Characteristics

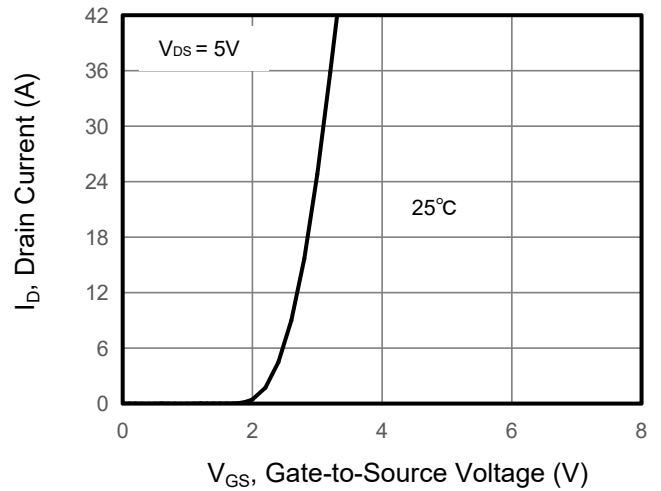

Figure 3. Drain Source On Resistance

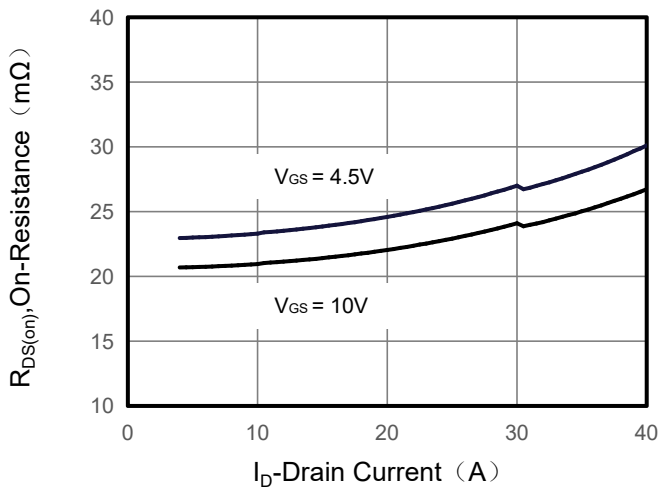

Figure 4. Gate Charge

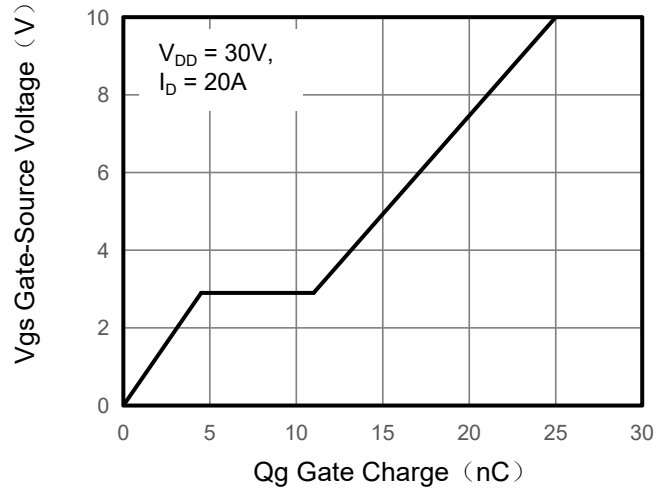

Figure 5. Capacitance

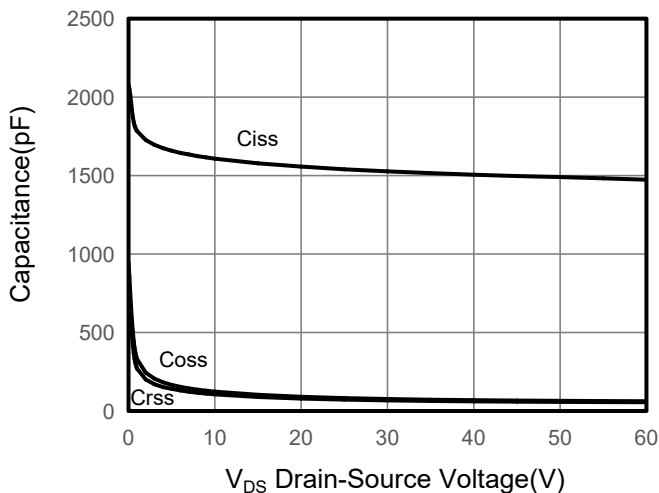
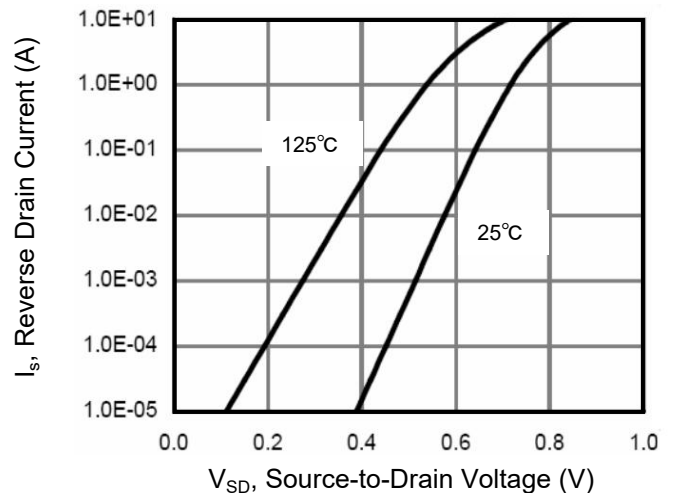

Figure 6. Source-Drain Diode Forward



Typical Characteristics $T_J = 25^\circ\text{C}$, unless otherwise noted

Figure 7. Drain-Source On-Resistance

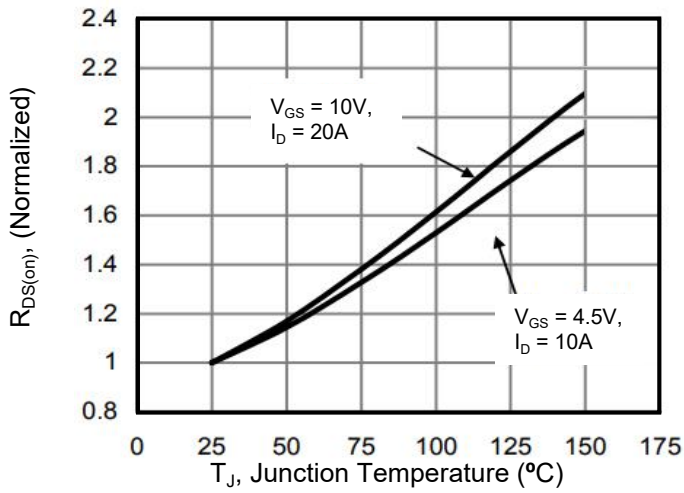

Figure 8. Safe Operation Area

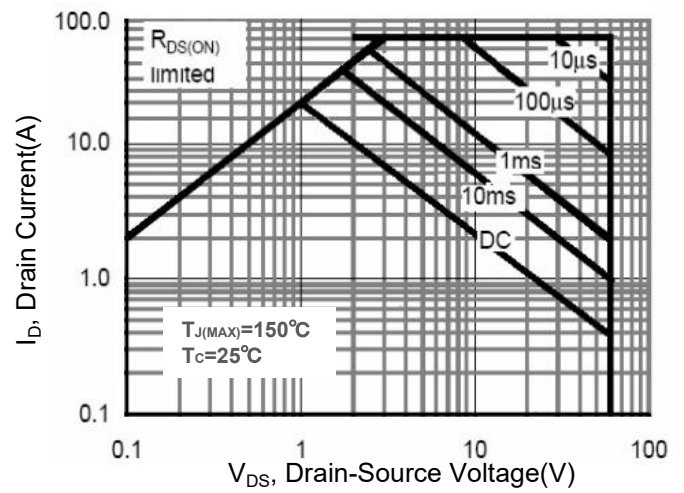
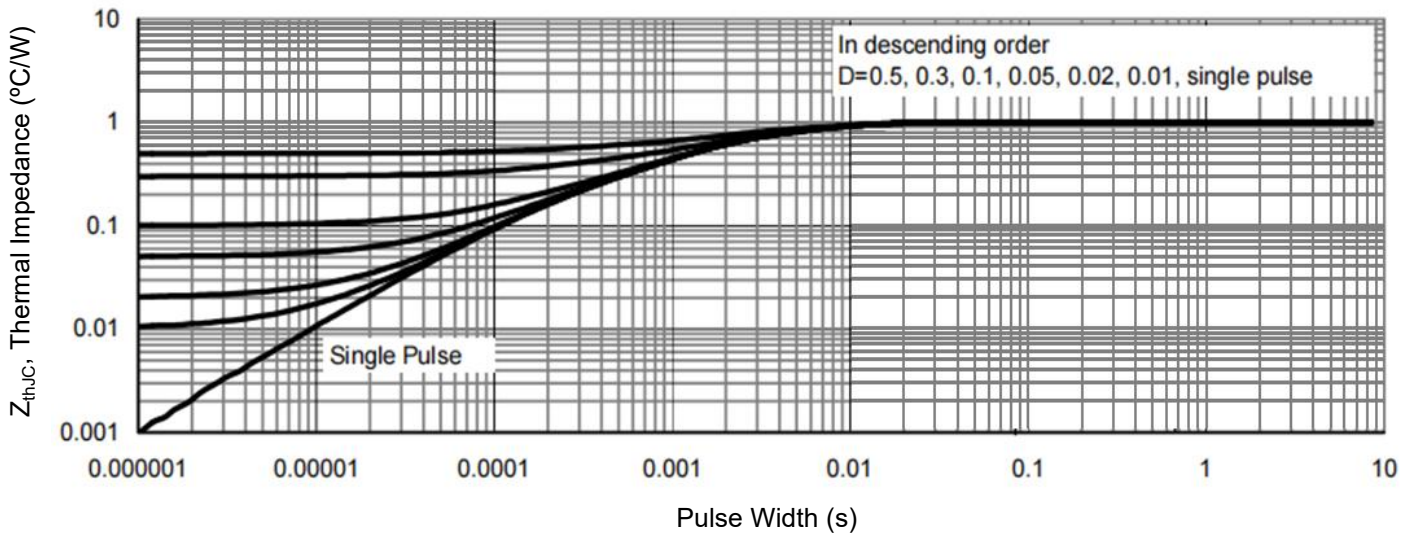
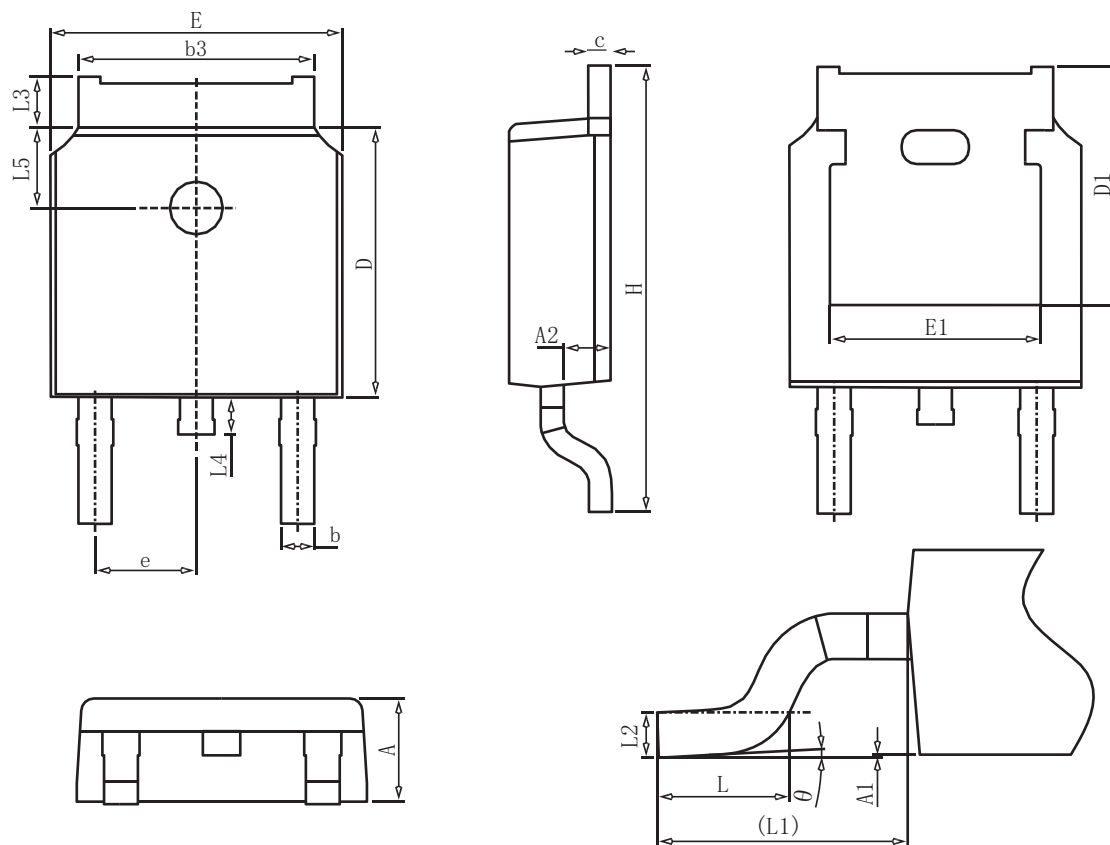

Figure 9. Normalized Maximum Transient Thermal Impedance



TO-252 Package Information



COMMON DIMENSIONS

| SYMBOL | mm | | |
|--------|----------|-------|-------|
| | MIN | NOM | MAX |
| A | 2.20 | 2.30 | 2.40 |
| A1 | 0.00 | - | 0.20 |
| A2 | 0.97 | 1.07 | 1.17 |
| b | 0.68 | 0.78 | 0.90 |
| b3 | 5.20 | 5.33 | 5.50 |
| c | 0.43 | 0.53 | 0.63 |
| D | 5.98 | 6.10 | 6.22 |
| D1 | 5.30REF | | |
| E | 6.40 | 6.60 | 6.80 |
| E1 | 4.63 | - | - |
| e | 2.286BSC | | |
| H | 9.40 | 10.10 | 10.50 |
| L | 1.38 | 1.50 | 1.75 |
| L1 | 2.90REF | | |
| L2 | 0.51BSC | | |
| L3 | 0.88 | - | 1.28 |
| L4 | 0.50 | - | 1.00 |
| L5 | 1.65 | 1.80 | 1.95 |
| θ | 0° | - | 8° |