

PART NAME: KNOB SCALE: 1:1 DATE: 2/28/97 DR. BY HD

THIS DRAWING IS THE PROPERTY OF DAVIES MOLDING COMPANY, IS SUBMITTED SOLELY AS A DESIGN OR ENGINEERING PROJECT. WE ACCEPT NO RESPONSIBILITY WHATSOEVER FOR THE PRACTICAL APPLICATION OF THE PIECES MADE TO THIS DESIGN.

DAVIES MOLDING COMPANY
CAROL STREAM, ILLINOIS 60188

P/N 1202BZ	
BASE PART	1202-08
CAP INLAY	I0786(SCL)

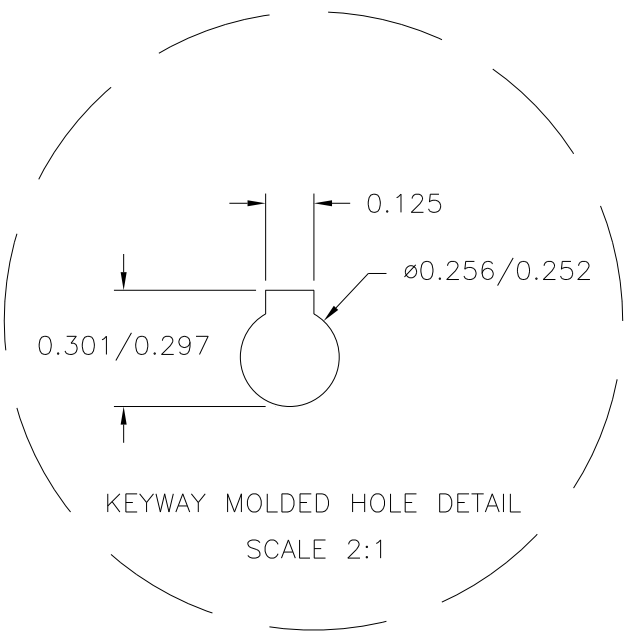
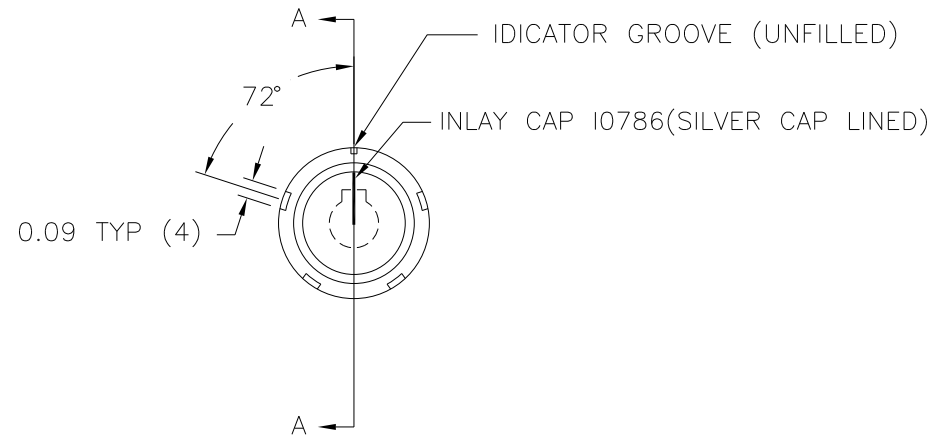

SECTION A-A

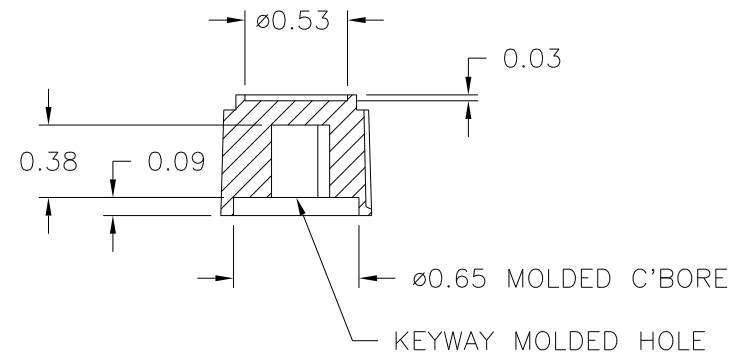
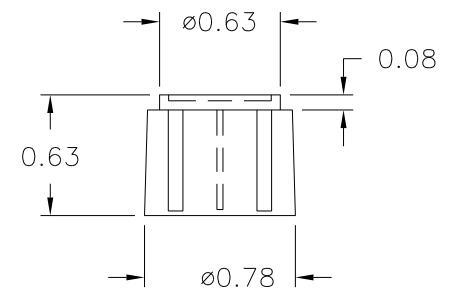

NOTE: ALL MOLDED PARTS MUST BE CHECKED WITH SPECIAL GAUGE.
KEYWAY PIN MUST ACCEPT MOLDED HOLE

MATERIAL: G.P. PHENOLIC (B11)
COLOR: BLACK

TOLERANCES: UNLESS OTHERWISE SPECIFIED	DO NOT SCALE DRAWING				
DECIMALS: X.XXX ± .005 X.XX ± .015	MM: X.XX ± 0.15MM X.X ± 0.4MM	-	UPDATED/HAD TOOLBOX	ST	4/5/2000
FRACTIONS ± 1/64	ANG. ± 1°	-	CAD/REDRAWN	HD	9/9/93
CHANGES					

PART NAME: KNOB SCALE: 1:1 DATE: 2/28/97 DR. BY HD

THIS DRAWING IS THE PROPERTY OF DAVIES MOLDING COMPANY, IS SUBMITTED SOLELY AS A DESIGN OR ENGINEERING PROJECT.
 WE ACCEPT NO RESPONSIBILITY WHATSOEVER FOR THE PRACTICAL APPLICATION OF THE PIECES MADE TO THIS DESIGN.

DAVIES MOLDING COMPANY
 CAROL STREAM, ILLINOIS 60188

P/N 1202BZ

BASE PART	1202-08
CAP INLAY	I0786(SCL)

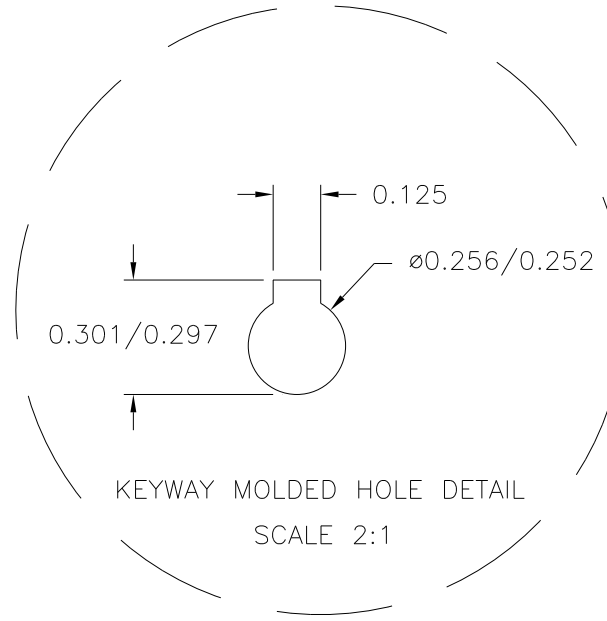
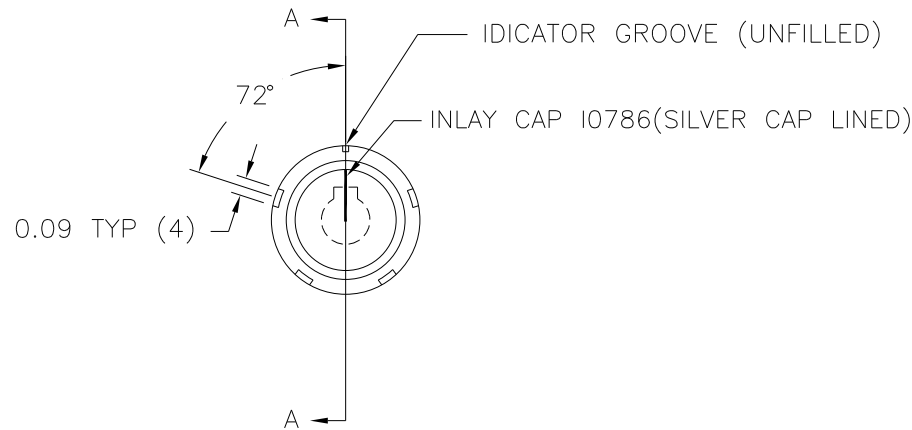

SECTION A-A

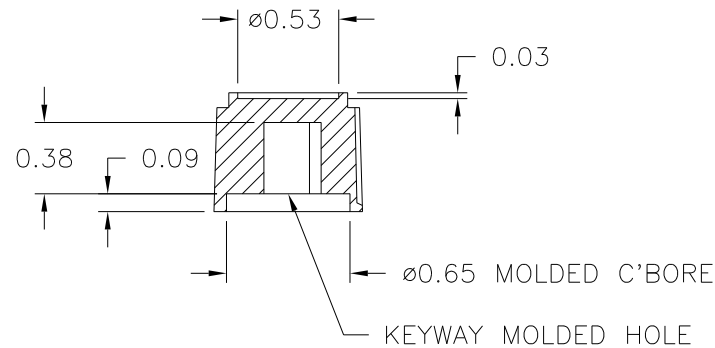
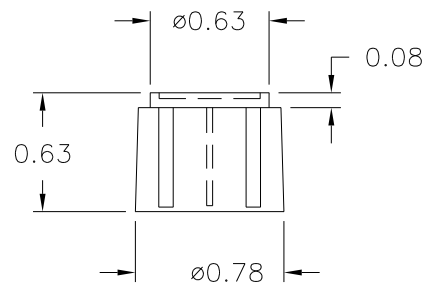

NOTE: ALL MOLDED PARTS MUST BE CHECKED WITH SPECIAL GAUGE.
 KEYWAY PIN MUST ACCEPT MOLDED HOLE

MATERIAL: G.P. PHENOLIC (B11)
 COLOR: BLACK

TOLERANCES: UNLESS OTHERWISE SPECIFIED	DO NOT SCALE DRAWING				
DECIMALS: X.XXX ± .005 X.XX ± .015	MM: X.XX ± 0.15MM X.X ± 0.4MM	-	UPDATED/HAD TOOLBOX	ST	4/5/2000
FRACTIONS ± 1/64	ANG. ± 1°	-	CAD/REDRAWN	HD	9/9/93
CHANGES					