

LOC	DIST	REVISIONS					
GP	00	#	LY#	DESCRIPTION	DATE	OWN	APVD
		1		PRELIMINARY	24SEP2013	ZJ	JY
		A		ACTIVE THE DRAWING	31DEC2013	ZJ	JY
		B		REVISED PER ECO-15-005721	4AUG2015	RG	SH
		D		REVISED PER ECO-19-004279	20MAR2019	TX	SH

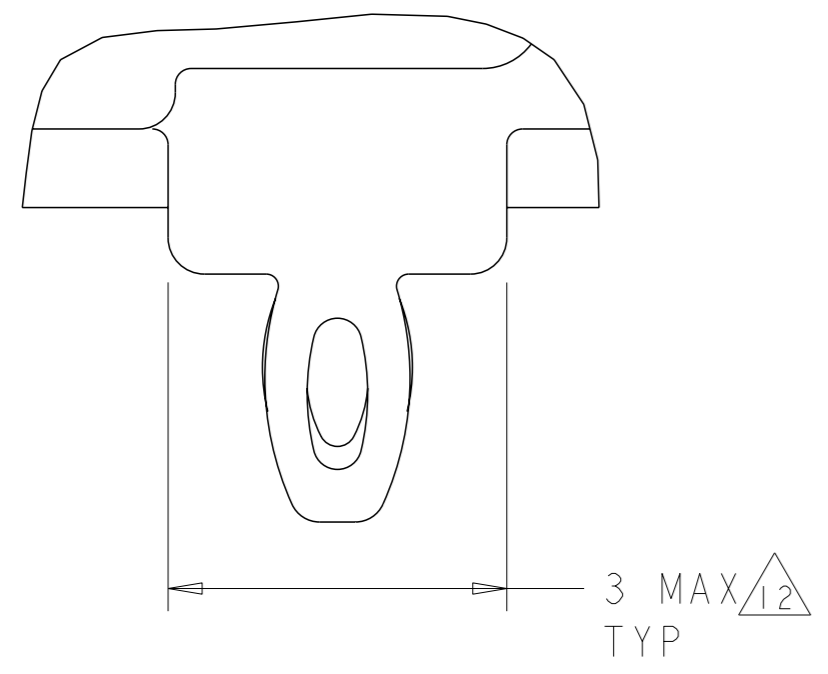

DETAIL S
SCALE 16:1

- 1. CAGE ASSEMBLY MATERIAL: NICKEL SILVER, 0.25 THICK
- HEAT SINK MATERIAL: ALUMINUM
- HEAT SINK CLIP MATERIAL: STAINLESS STEEL
- EMI SPRING MATERIAL: COPPER ALLOY
- FRONT FLANGE MATERIAL: ZINC ALLOY
- 2. PITCH BETWEEN PORTS OF ONE 1X4 CAGE ASSEMBLY.
- 3. SPACING BETWEEN CAGES ON THE SAME PC BOARD, TO BE SPECIFIED BY CUSTOMER, MUST COMPLY WITH MINIMUM DIMENSIONS SHOWN.
- 4. REFERENCE APPLICATION SPEC 114-13218 FOR RECOMMENDED DRILL HOLE DIAMETER AND PLATING THICKNESS.
- 5. DATUMS AND BASIC DIMENSIONS ESTABLISHED BY CUSTOMER.
- 6. DIMENSION C IS THE NOMINAL THICKNESS OF CUSTOMER SUPPLIED PC BOARD, SINGLE SIDED PC BOARD MINIMUM THICKNESS = 1.45mm, DOUBLE SIDED PC BOARD MINIMUM THICKNESS = 2.2mm PER QSFP.
- 7. HEAT SINKS AND CLIPS SHIPPED ASSEMBLED TO CAGE ASSEMBLY. CAGE ASSEMBLY MAY BE PRESSED INTO THE PCB AS SHIPPED.
- 8. DATUM -A- IS TOP SURFACE OF PC BOARD.
- 9. DIMENSION APPLIES WITH MODULE INSERTED IN CAGE.
- 10. UNPLATED THRU HOLE.

- 11. MATES WITH QSFP MSA COMPATIBLE TRANSCEIVER.
- 12. SURFACE TRACES PERMITTED WITHIN THIS AREA EXCEPT WHERE CAGE STANDOFFS, SHOWN IN DETAIL A AND S, CONTACT PC BOARD.
- 13. BASELINE FOR THESE DIMENSIONS IS THE CENTER OF COMPLIANT PIN HOLE.
- 14. 2D BARCODE AND DATE CODE (YYWW) MARKED ON SIDE OF CAGE.
- 15. REFERENCE APP SPEC 114-13218 FOR GASKET THICKNESS CALCULATION.
- 16. EMI SPRING FINISH: 2µm MINIMUM TIN
FRONT FLANGE FINISH: 3µm MINIMUM TIN OVER 1.27µm MINIMUM NICKEL OVER 5.08µm MINIMUM COPPER.
HEAT SINK FINISH: NICKEL.

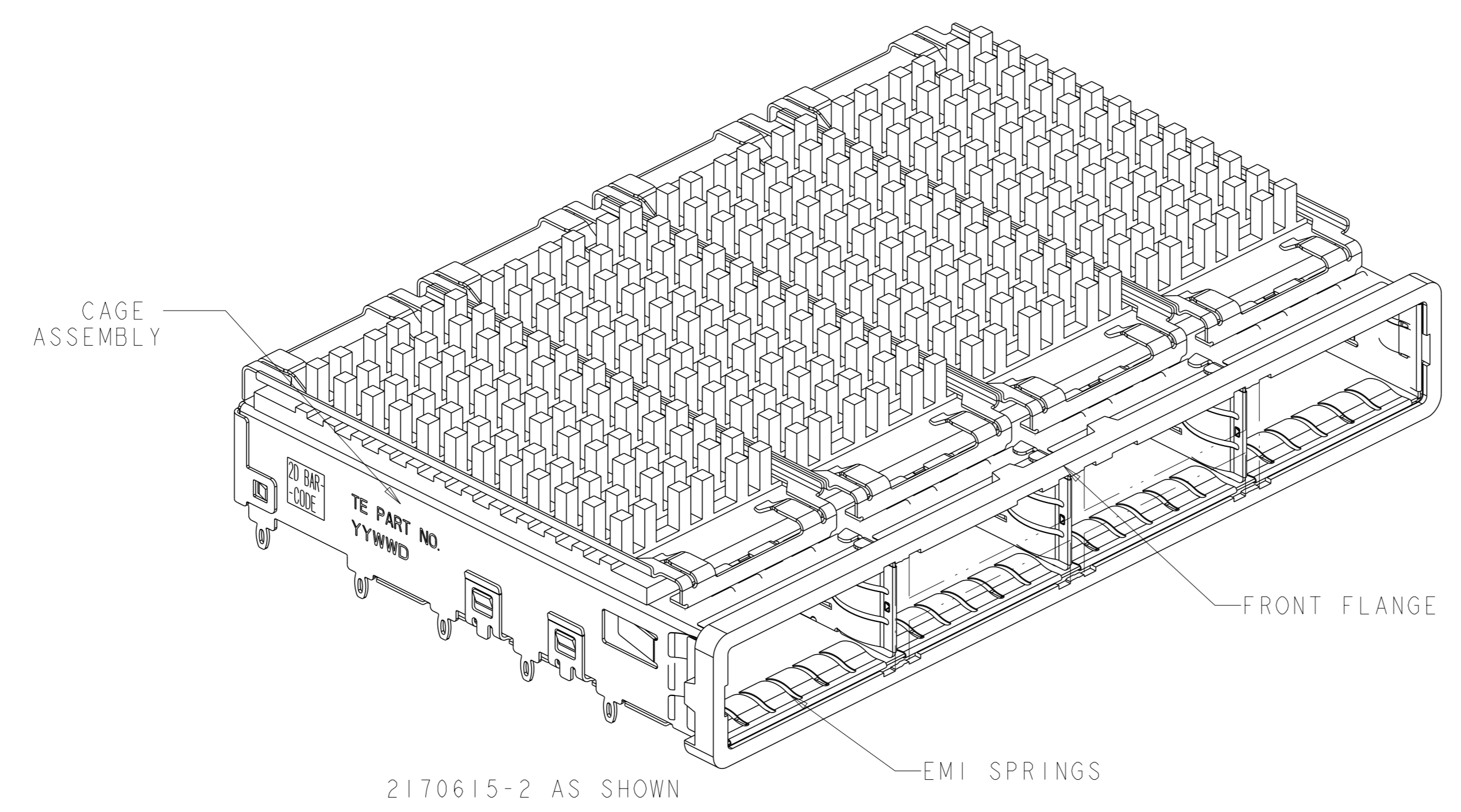
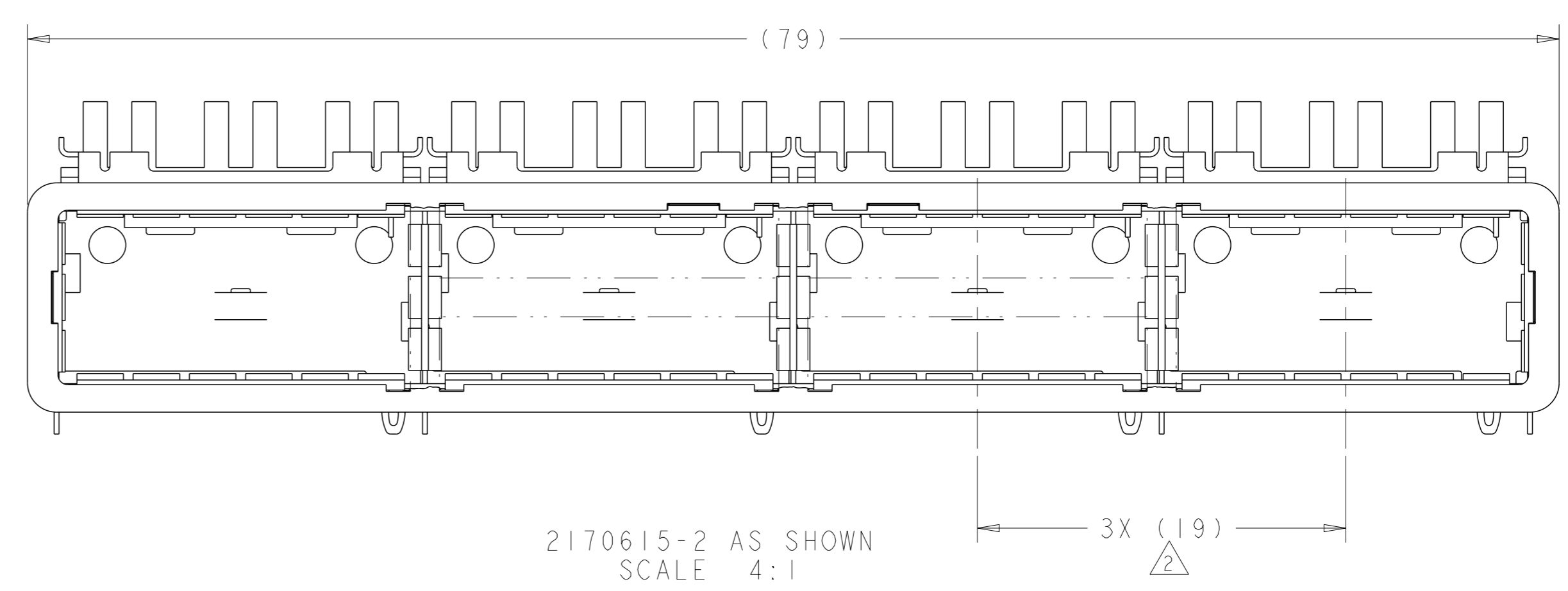
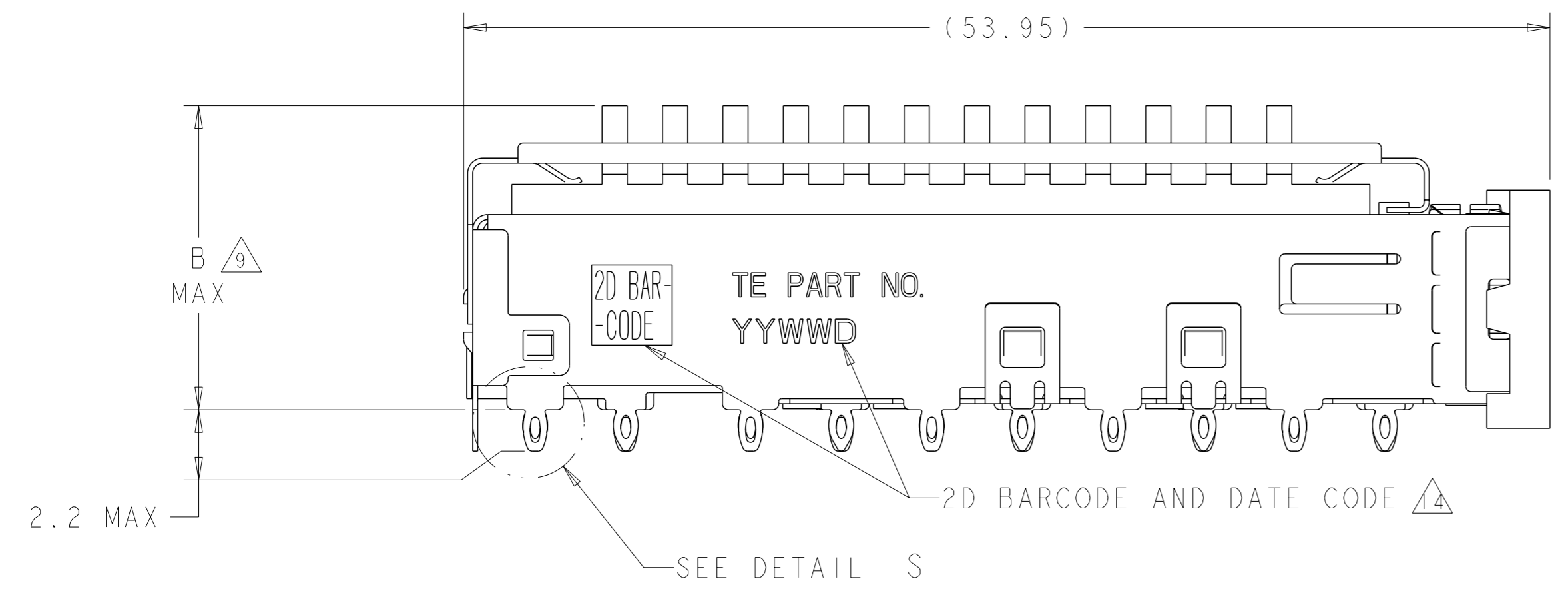

23.0	NETWORKING	2170615-4
16.0	SAN	2170615-2
13.7	PCI	2170615-1
B	HEAT SINK PROFILE	PART NUMBER

THIS DRAWING IS A CONTROLLED DOCUMENT. OWN: ZJ, CHK: JY, APVD: MC, DATE: 24SEP2013

DIMENSIONS: mm. TOLERANCES UNLESS OTHERWISE SPECIFIED: 0 PLC ±, 1 PLC ±0.1, 2 PLC ±0.1, 3 PLC ±, 4 PLC ±, ANGLES FINISH ±.

MATERIAL: 1. FINISH: 16.

Customer Drawing

SCALE 1:1 SHEET 1 OF 6 REV D

TE Connectivity

NAME: 1X4 CAGE ASSEMBLY, BEHIND BEZEL, W/ HEAT SINKS, QSFP

PRODUCT SPEC: 108-2286

APPLICATION SPEC: 114-13218

SIZE: A1 CAGE CODE: 00779 DRAWING NO: 2170615

LOC	DIST	REVISIONS			
GP	00	REV	DATE	OWN	APVD
		-	SEE SHEET 1	-	-

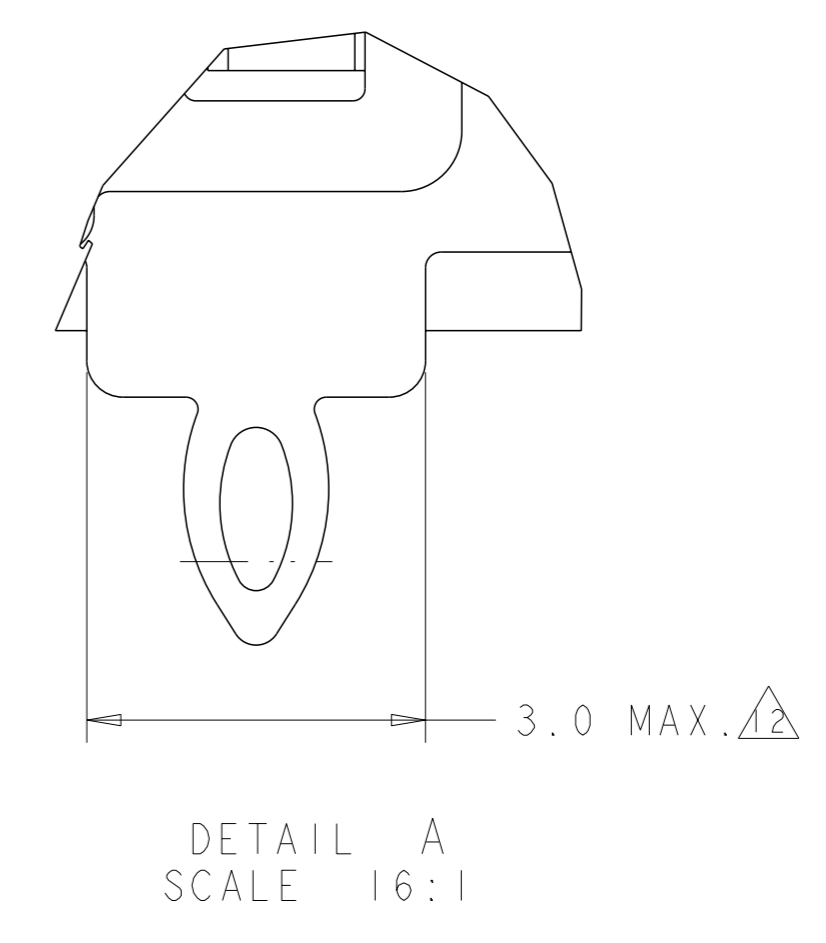
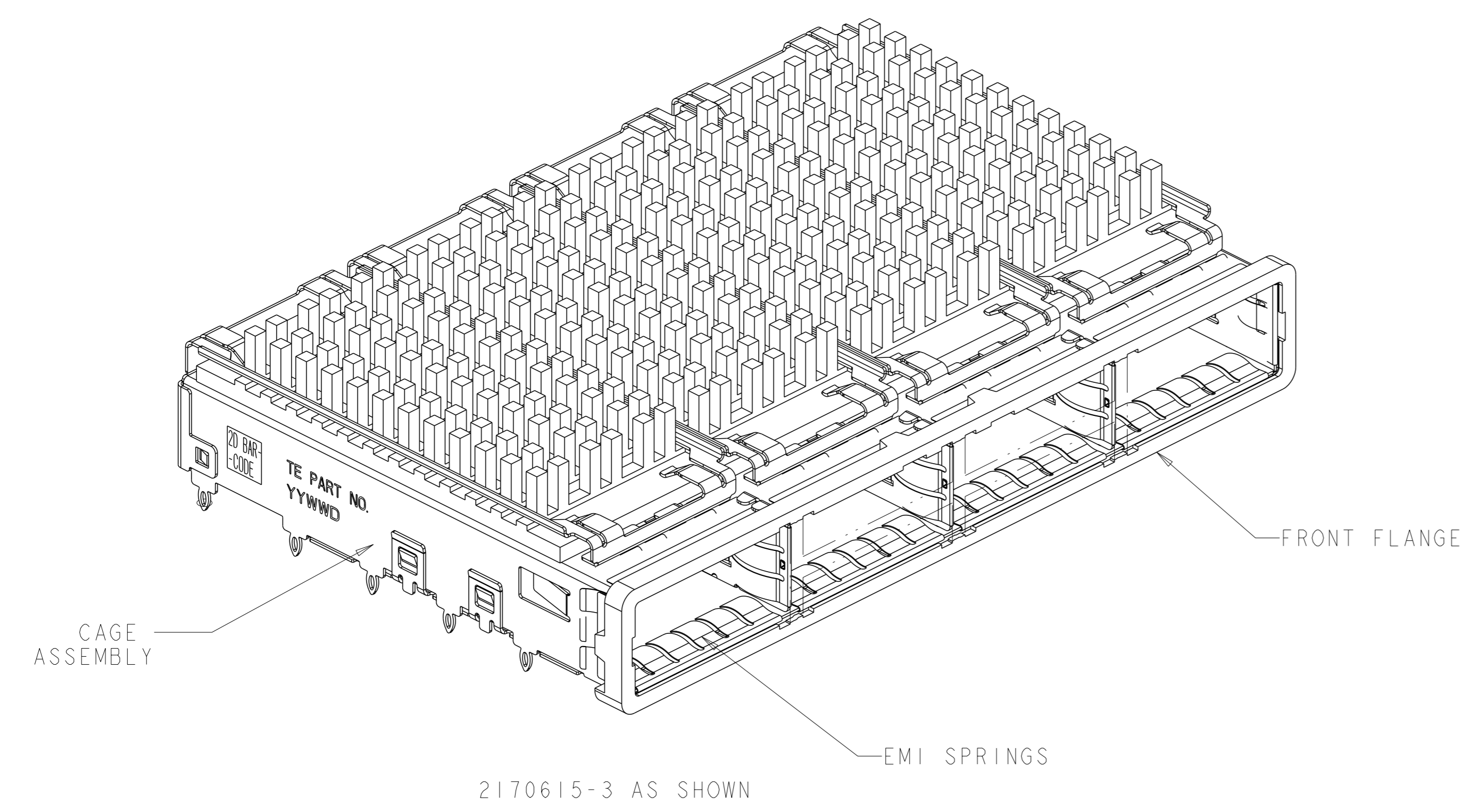
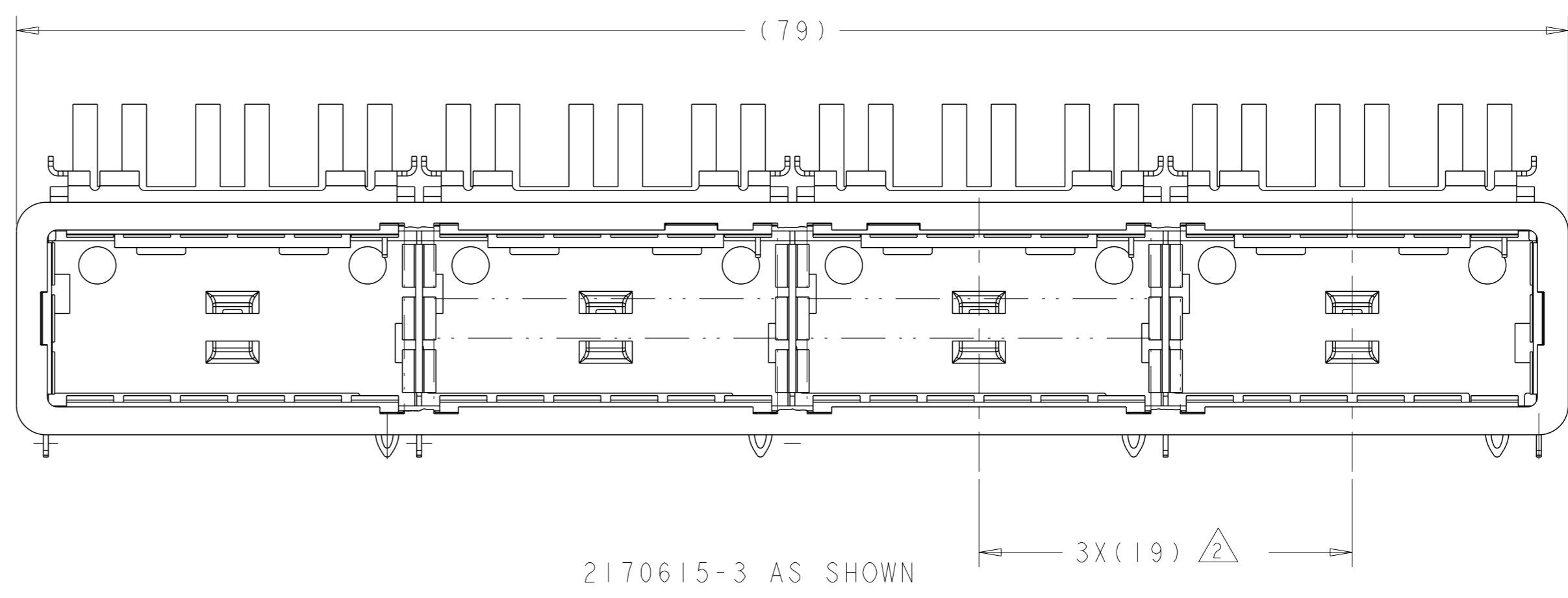
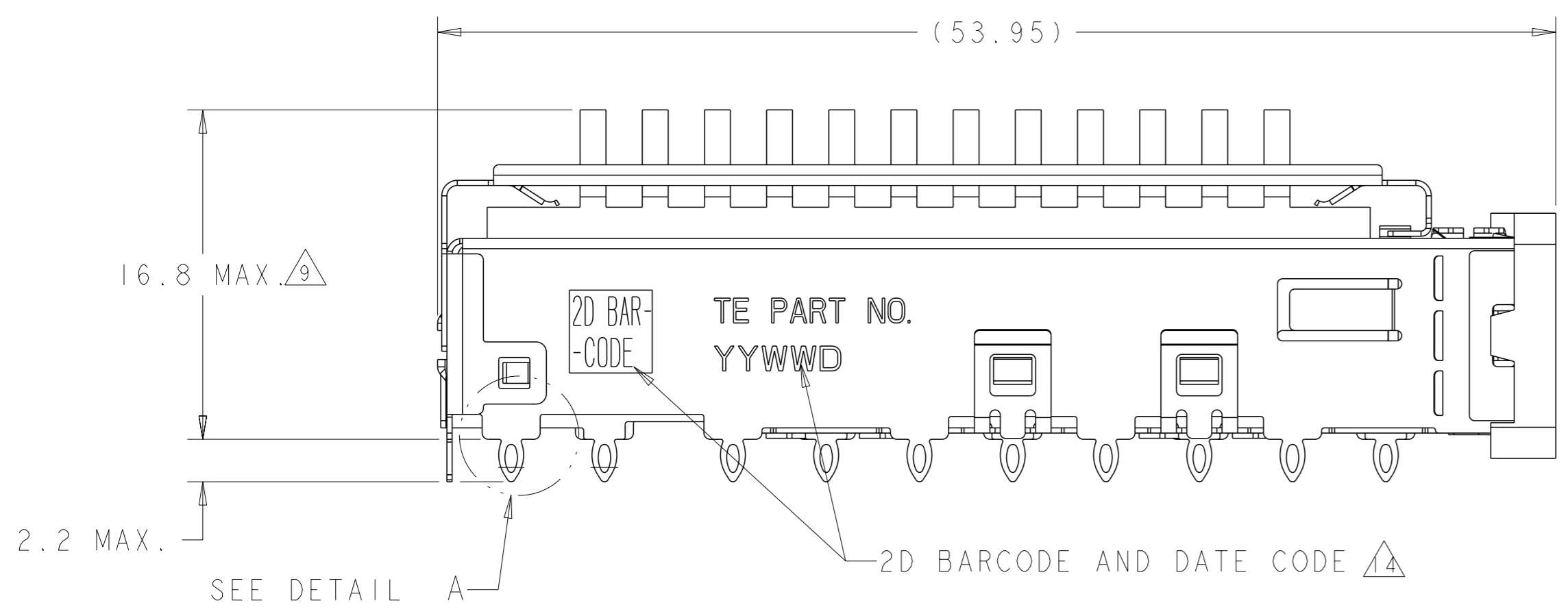

CUSTOMIZED	2170615-3
HEAT SINK PROFILE	PART NUMBER

THIS DRAWING IS A CONTROLLED DOCUMENT.		OWN: ZJ	24SEP2013	TE Connectivity NAME: 1X4 CAGE ASSEMBLY, BEHIND BEZEL, W/ HEAT SINKS, QSFP PRODUCT SPEC: 108-2286 APPLICATION SPEC: 114-13218
DIMENSIONS:		CHK: JY	24SEP2013	
TOLERANCES UNLESS OTHERWISE SPECIFIED:		APVD: MC	24SEP2013	
mm		0 PLC ±	1 PLC ±0.1	
		2 PLC ±0.1	3 PLC ±	
MATERIAL:		4 PLC ±	ANGLES ±	
		FINISH	WEIGHT	RESTRICTED TO
			Customer Drawing	SCALE: 1:1 SHEET 2 OF 6 REV D

LOC		DIST		REVISIONS			
GP	00	P	LYR	DESCRIPTION	DATE	OWN	APVD
		-		SEE SHEET 1	-	-	-

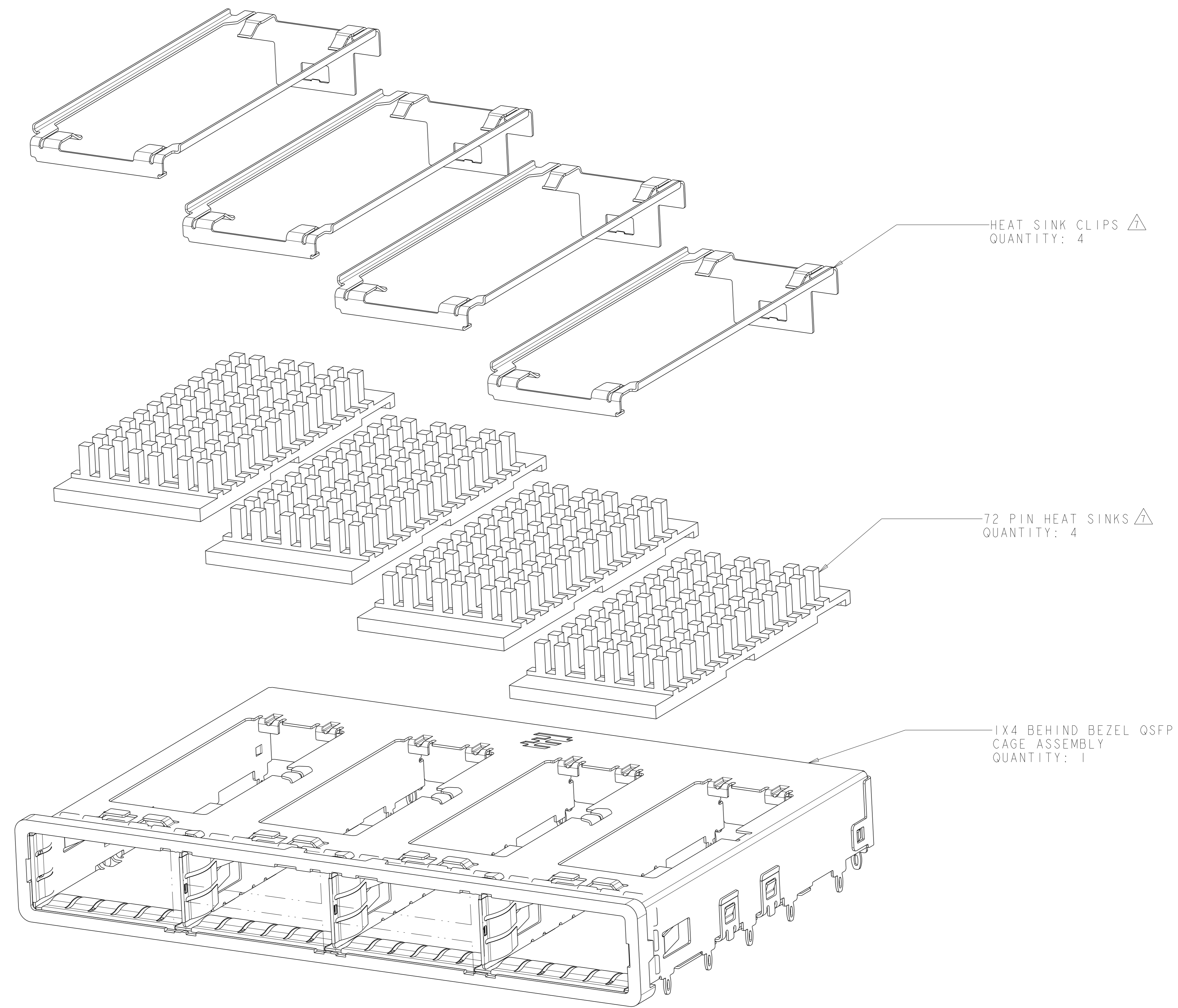

2170615-2 AS SHOWN

THIS DRAWING IS A CONTROLLED DOCUMENT.		OWN	ZJ	24SEP2013	
		CHK	JY	24SEP2013	
		APVD	MC	24SEP2013	NAME 1X4 CAGE ASSEMBLY, BEHIND BEZEL, W/ HEAT SINKS, QSFP
		PRODUCT SPEC		108-2286	
		APPLICATION SPEC		114-13218	RESTRICTED TO
		WEIGHT		-	SIZE
		MATERIAL		-	CAGE CODE
		FINISH		-	DRAWING NO
		DIMENSIONS:		A100779C=2170615	
		TOLERANCES UNLESS OTHERWISE SPECIFIED:		SCALE	
		0 PLC ±		1:1	
		1 PLC ±0.1		SHEET	
		2 PLC ±0.1		3	
		3 PLC ±		OF	
		4 PLC ±		6	
		ANGLES ±		REV	
		FINISH ±		D	
		CUSTOMER DRAWING			

LOC	DIST	REVISIONS					
GP	00	P	LYR	DESCRIPTION	DATE	DWN	APVD
-	-	-	-	SEE SHEET 1	-	-	-

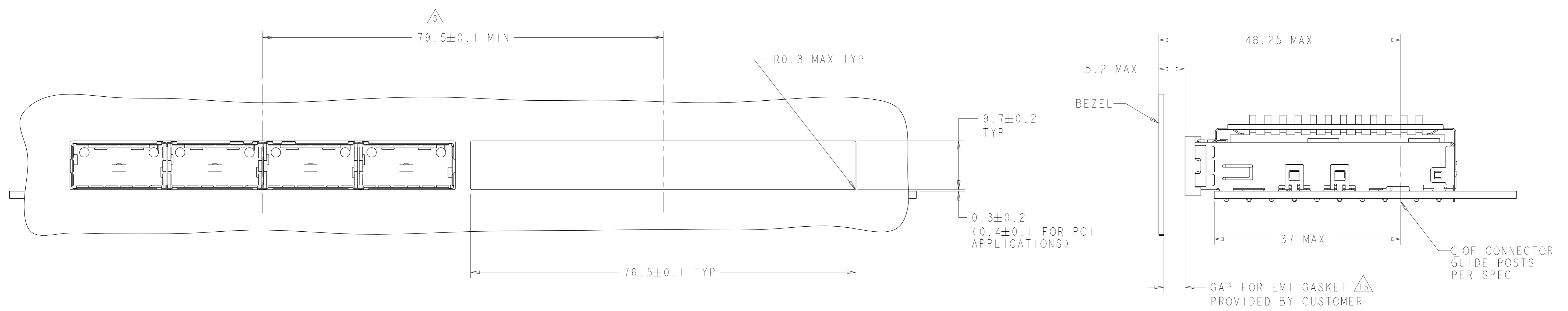

ONE SIDED CONFIGURATION
 SCALE 5:2

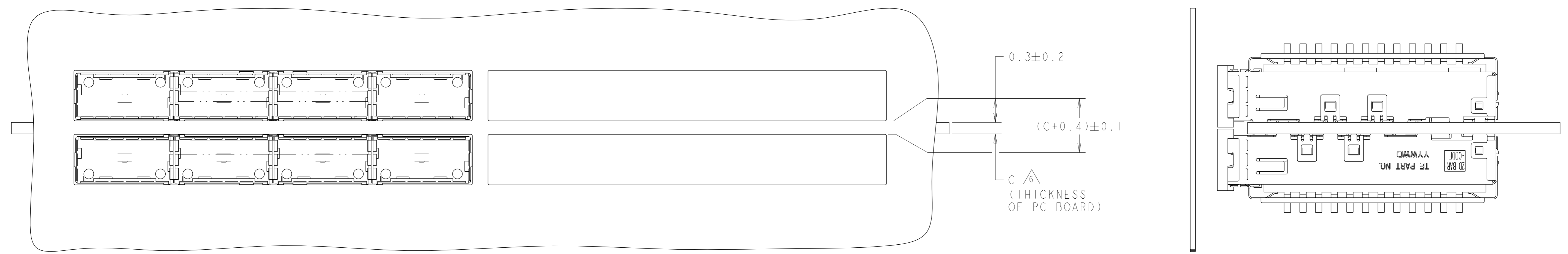

BELLY TO BELLY CONFIGURATION SIMILAR
 TO ONE SIDED EXCEPT WHERE NOTED
 SCALE 5:2

THIS DRAWING IS A CONTROLLED DOCUMENT.		DWN ZJ	24SEP2013	TE TE Connectivity
DIMENSIONS:		CHK JY	24SEP2013	
mm	TOLERANCES UNLESS OTHERWISE SPECIFIED:	APVD MC	24SEP2013	NAME 1X4 CAGE ASSEMBLY, BEHIND BEZEL, W/ HEAT SINKS, QSFP
0 PLC ±	1 PLC ±0.1	PRODUCT SPEC	108-2286	SIZE -
2 PLC ±0.1	3 PLC ±	APPLICATION SPEC	114-13218	CAGE CODE DRAWING NO A100779C=2170615
4 PLC ±	ANGLES ±	FINISH	Customer Drawing	RESTRICTED TO -
MATERIAL			WEIGHT	SCALE 1:1 SHEET 4 OF 6 REV D

LOC	DIST	REV	DESCRIPTION	DATE	OWN	APVD
GP	00		SEE SHEET 1			

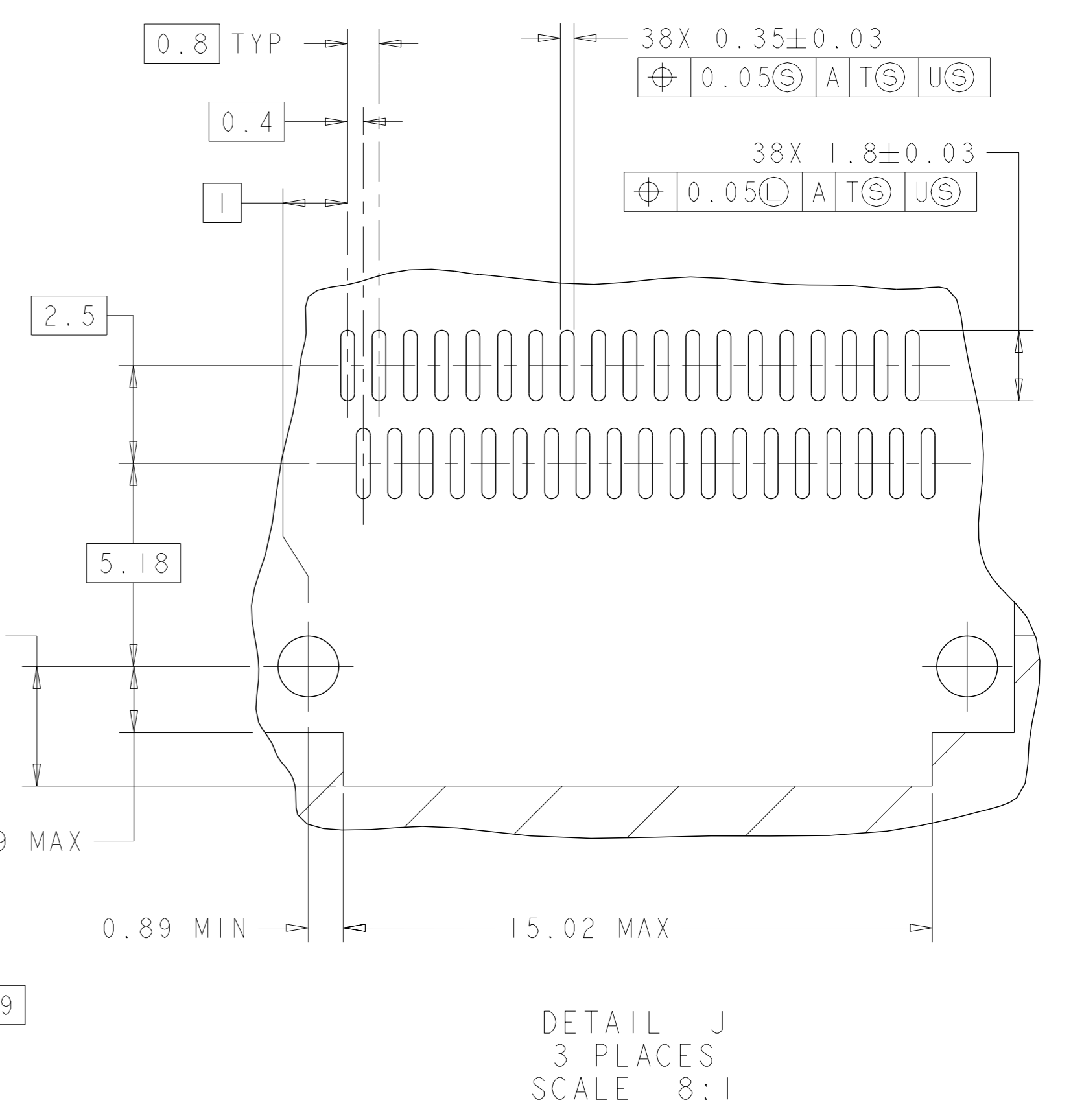
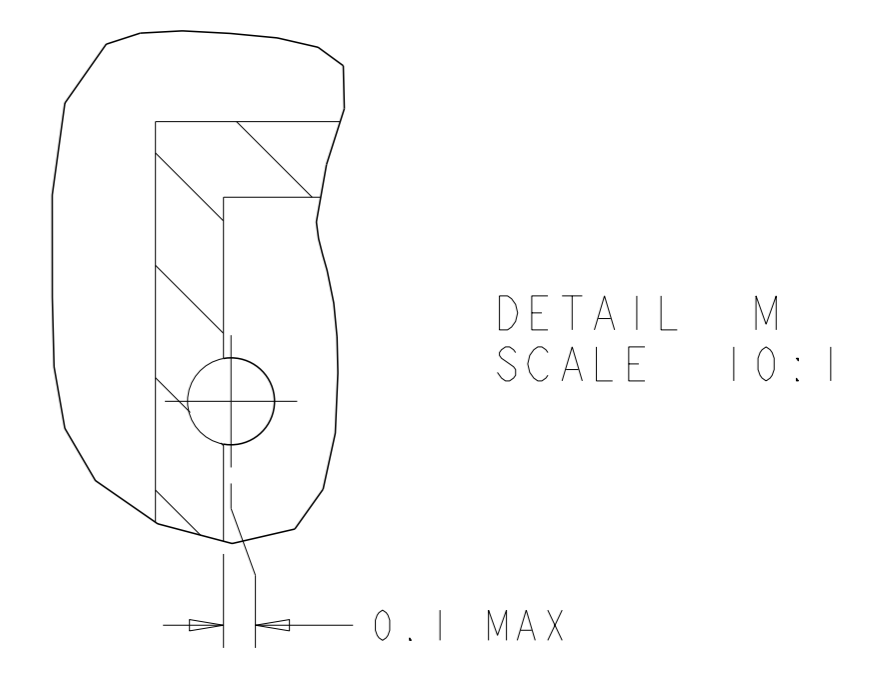
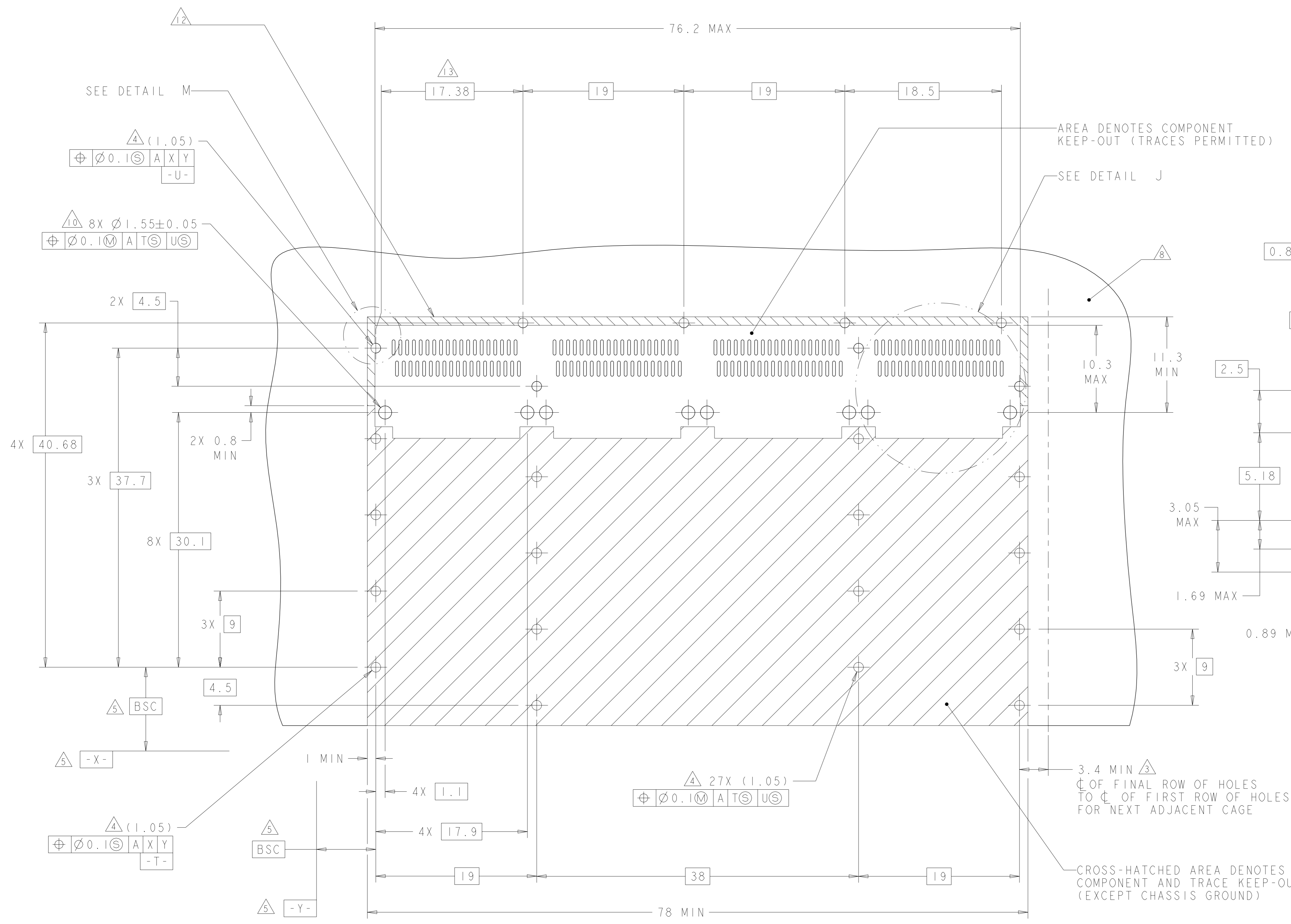

RECOMMENDED PC BOARD LAYOUT
 SINGLE SIDE MOUNT CONFIGURATION
 SCALE 4:1

THIS PRODUCT HAS NOT COMPLETED VALIDATION/QUALIFICATION TESTING

THIS DRAWING IS A CONTROLLED DOCUMENT.		OWN: ZJ	24SEP2013		TE Connectivity
DIMENSIONS: mm		CHK: JY	24SEP2013		
TOLERANCES UNLESS OTHERWISE SPECIFIED:		APVD: MC	24SEP2013	NAME: 1X4 CAGE ASSEMBLY, BEHIND BEZEL, W/ HEAT SINKS, QSFP	
0 PLC	±	PRODUCT SPEC		SIZE: 108-2286	
1 PLC	±0.1	APPLICATION SPEC		CAGE CODE: 114-13218	
2 PLC	±0.1	MATERIAL		RESTRICTED TO: A100779C=2170615	
3 PLC	±	FINISH		SCALE: 1:1	
4 PLC	±	WEIGHT		SHEET 5 OF 6	
ANGLES	±	Customer Drawing		REV D	

LOC	DIST	REVISIONS			
GP	00	REV	DATE	OWN	APVD
-	-	SEE SHEET 1	-	-	-

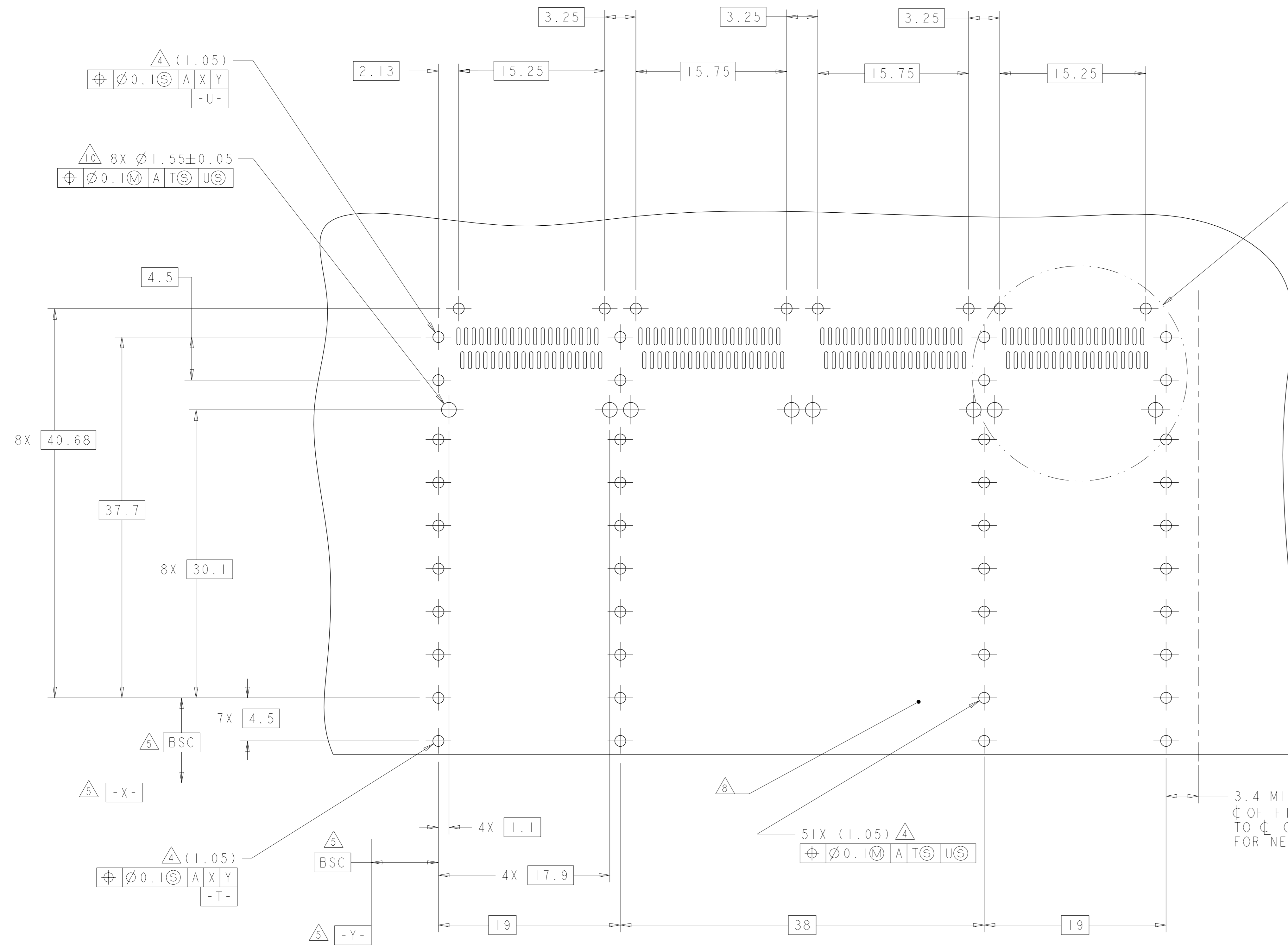

SEE DETAIL K

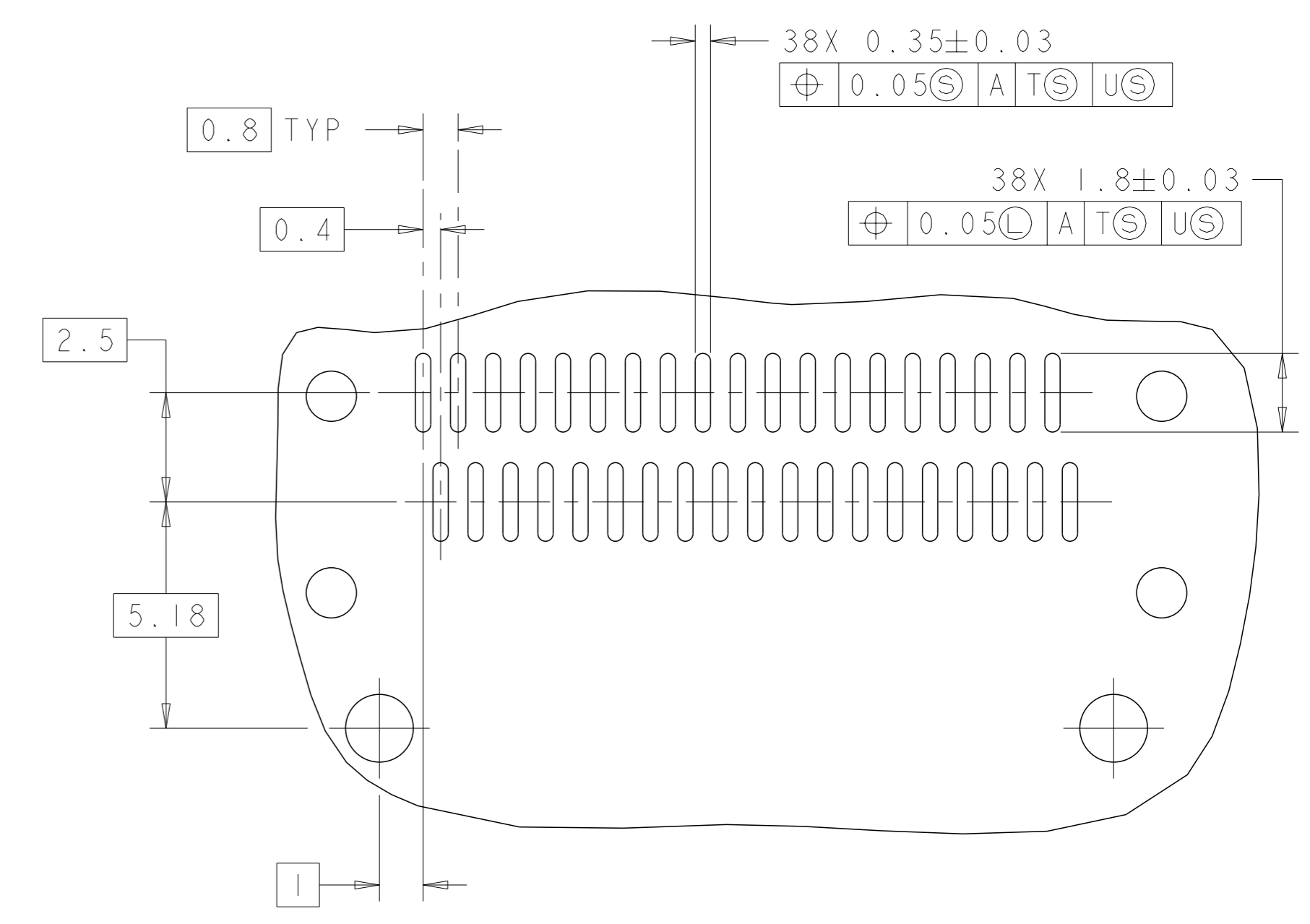

DETAIL K
SCALE 8:1

RECOMMENDED PC BOARD LAYOUT
 BELLY TO BELLY CONFIGURATION
 SEE SHEET 4 FOR COMPONENT
 AND TRACE KEEP-OUTS
 SCALE 4:1

3.4 MIN Δ
 ϕ OF FINAL ROW OF HOLES
 TO ϕ OF FIRST ROW OF HOLES
 FOR NEXT ADJACENT CAGE

THIS PRODUCT HAS NOT COMPLETED VALIDATION/QUALIFICATION TESTING

THIS DRAWING IS A CONTROLLED DOCUMENT.		OWN: ZJ	24SEP2013	TE Connectivity NAME: 1X4 CAGE ASSEMBLY, BEHIND BEZEL, W/ HEAT SINKS, QSFP
DIMENSIONS: mm		CHK: JY	24SEP2013	
TOLERANCES UNLESS OTHERWISE SPECIFIED:		APVD: MC	24SEP2013	
0 PLC ± 1 PLC ±0.1 2 PLC ±0.1 3 PLC ± 4 PLC ± ANGLES FINISH ±		PRODUCT SPEC: 108-2286	APPLICATION SPEC: 114-13218	
MATERIAL:		WEIGHT:	114-13218	SIZE: A1
		Customer Drawing		RESTRICTED TO: -
		SCALE: 1:1		SHEET: 6 OF 6
				REV: D