

DWG. NO.	HH-3495-BC
ISSUE	REVISIONS

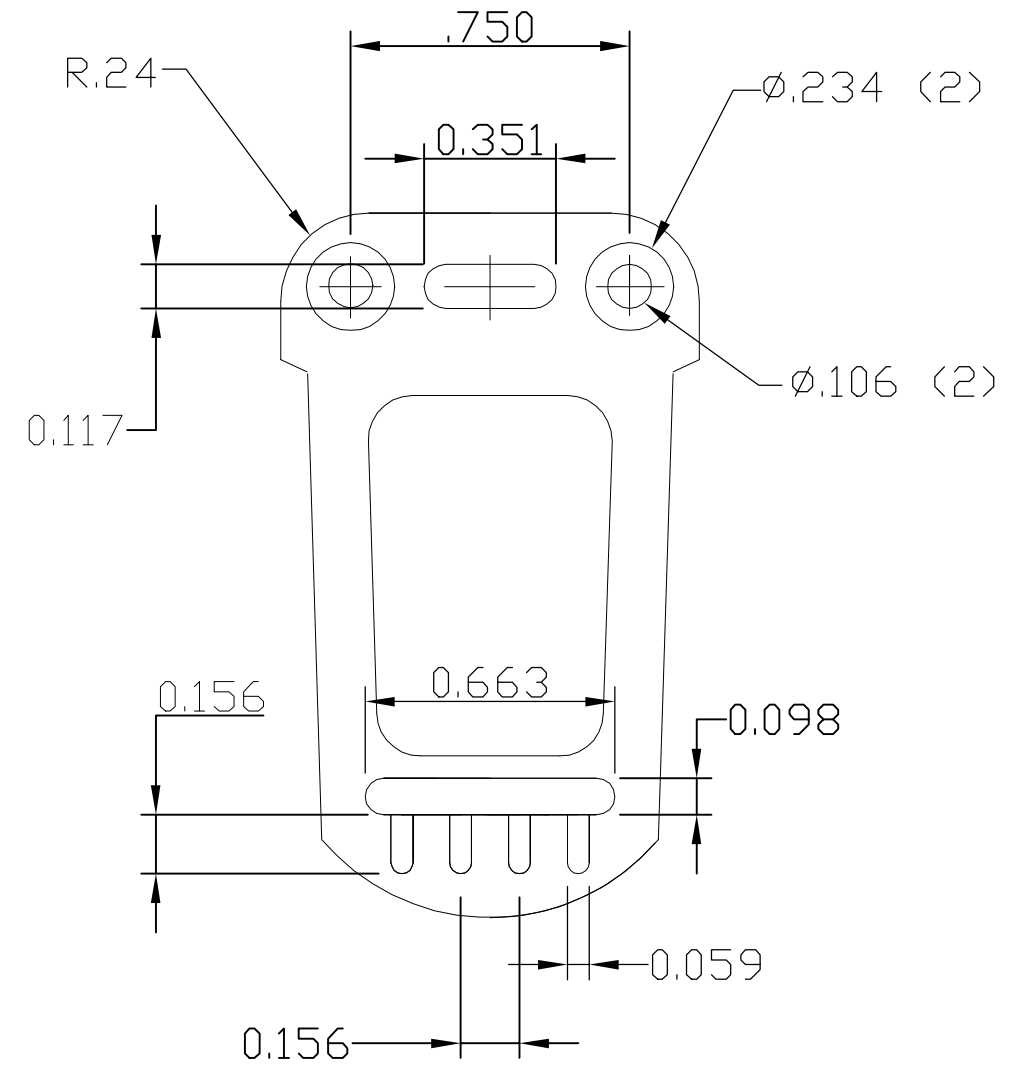
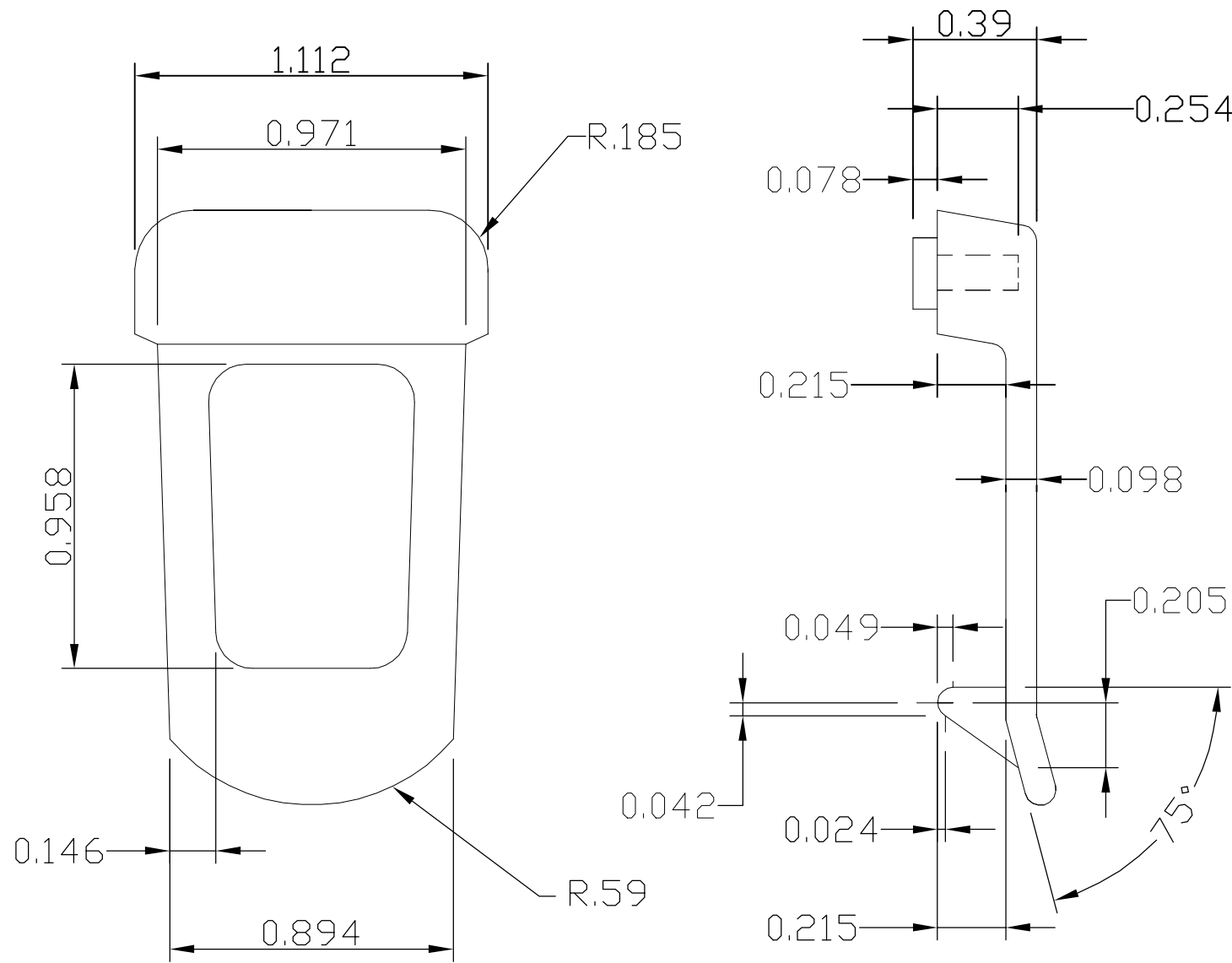

MATERIAL: ABS UL94-HB
 FINISH: LIGHT TEXTURE
 BLACK (HH-3595-BCB) OR
 LIGHT GRAY (HH-3595-BCG).

NOTES:

- 1) 2 PCS. MOUNTING HARDWARE INCLUDED (SCREW, M3.5x6mm, THREAD FORMING, ZINC PLATED STEEL).
- 2) TO MOUNT TO ENCLOSURE, DRILL (2) 0.234 DIA. MIN. HOLES ON .750 CENTERS

QTY.	USED ON	ITEM	REQ'D.	PART NO.	DESCRIPTION
		TOLERANCES: ±.005 BETWEEN HOLE CENTERS ±.015 FROM SHEARED EDGE ±.032 FROM A BENT SURFACE ±.063 BETWEEN ASSEMBLED SURFACES UNLESS OTHERWISE SPECIFIED		MAT: AS NOTED FINISH: AS NOTED DR. DP 5-24-05 CH. APP.	SCALE: BUD BUD INDUSTRIES, INC. WILLOUGHBY, OHIO NAME: BELT CLIP DWG. NO. HH-3595-BC