

TOSHIBA BiCD Process IC Silicon Monolithic

TB62206FG

BiCD PWM 2-Phase Bipolar Stepping Motor Driver

The TB62206FG is designed to drive a 2-phase bipolar stepping motor. With BiCD process technology, this device enables output withstand voltage of 40 V and maximum current of 1.8 A to be achieved.

Features

- Bipolar stepping motor driver IC
- Internal PWM current control
- 2-phase/1-2 phase excitation is available
- Monolithic BiCD IC
DMOS FET used for output power transistor
- High voltage output and High current: 40 V/1.8 A (max)
- On-chip thermal shutdown circuit, overcurrent protection circuit and power-on reset circuit (POR)
- Package: HSOP20-P-450-1.00

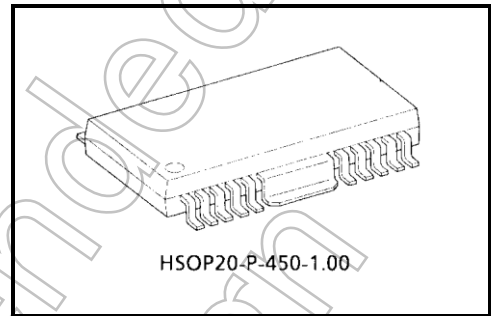

Weight: 0.79 g (typ.)

Pin Assignment

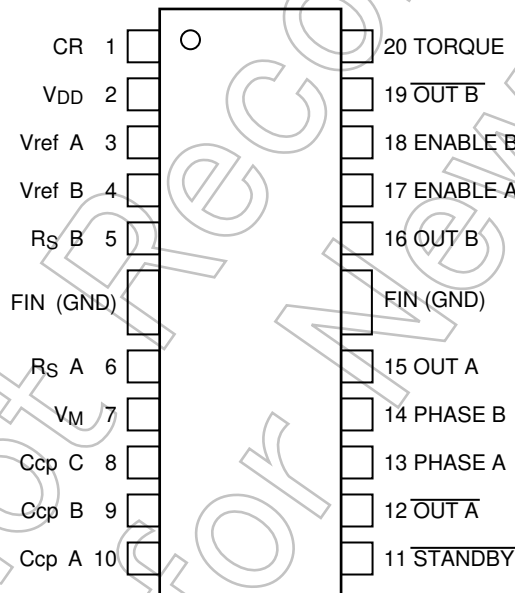

Note:

Please be careful about the thermal conditions during use, like operating current, PCB conditions, ambient temperature, etc.

This IC may be broken if it is soldered at wrongly rotated position because high voltage is applied to low voltage part.

Please be sure that 1PIN position and PCB pattern is correct before soldering process.

Block Diagram

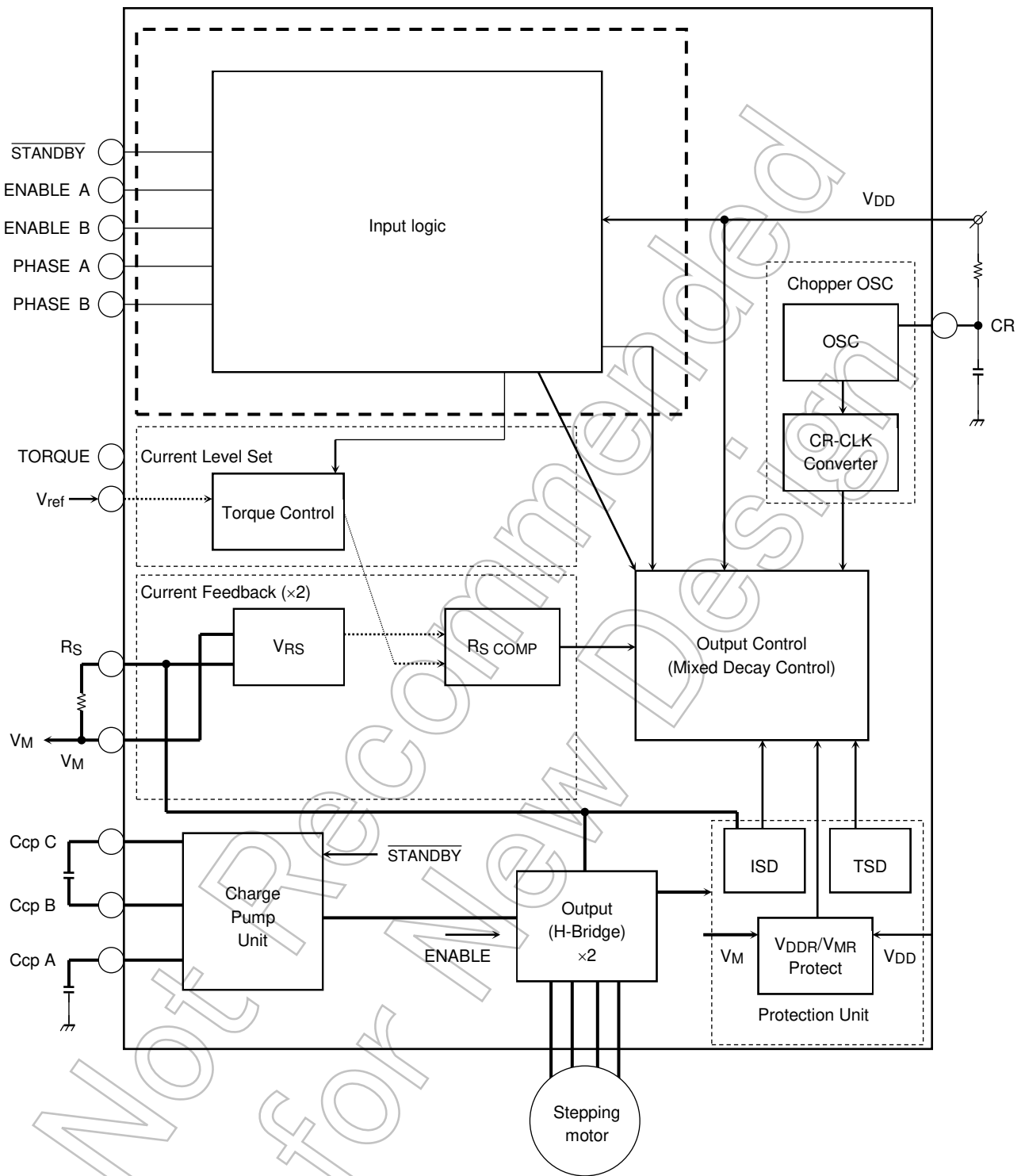

Function Table—Output

Phase	Enable	OUT X	$\overline{\text{OUT X}}$
X	L	OFF	OFF
H	H	H	L
L	H	L	H

X: Don't care

Others

Pin Name	H	L	Notes
ENABLE X	Output	Output OFF	Output is OFF regardless of its phase's state.
PHASE X	OUT X: H	OUT \bar{X} : H	In high level, current flows OUT X \rightarrow OUT \bar{X}
$\overline{\text{STANDBY}}$	Motor operation enable	All functions of the IC stopped	When $\overline{\text{STANDBY}} = \text{L}$, output stopped while charge pump stopped.
TORQUE	100%	71%	High-level

Protection Function

- (1) Thermal shutdown circuit
While $T_j = 150^\circ\text{C}$, all outputs are OFF. To turn-on, change the state of the $\overline{\text{STANDBY}}$ pin in the order of H, L, H.
It has temperature hysteresis to prevent the output from oscillating. ($\Delta T = 35^\circ\text{C}$)
- (2) POR (Power-On Reset Circuit: VM and VDD power supply monitor circuit)
Output is forcibly turned off until VM and VDD reach their specified levels.
- (3) ISD
Output is forcibly turned off when current higher than the specified level flows in the output block.
To turn-on, change the state of the $\overline{\text{STANDBY}}$ pin in the order of H, L, H.

Absolute Maximum Ratings (Ta = 25°C)

Characteristics	Symbol	Rating	Unit
Logic supply voltage	V _{DD}	7	V
Motor supply voltage	V _M	40	V
Output current (Note 1)	I _{OUT}	1.8	A
Current detect pin voltage	V _{RS}	V _M ± 4.5 V	V
Charge pump pin maximum voltage (CCP1 pin)	V _H	V _M + 7.0	V
Logic input voltage (Note 2)	V _{IN}	to V _{DD} + 0.4	V
Power dissipation	(Note 3)	1.4	W
	(Note 4)	3.2	
Operating temperature	T _{opr}	-40 to 85	°C
Storage temperature	T _{stg}	-55 to 150	°C
Junction temperature	T _j	150	°C

Note 1: Perform thermal calculations for the maximum current value under normal conditions. Use the IC at 1.5 A or less per phase.

The current value may be controlled according to the ambient temperature or board conditions.

Note 2: Input 7 V or less as V_{IN}

Note 3: Measured for the IC only. (Ta = 25°C)

Note 4: Measured when mounted on the board. (Ta = 25°C)

Ta: IC ambient temperature

T_{opr}: IC ambient temperature when starting operation

T_j: IC chip temperature during operation T_j (max) is controlled by TSD (thermal shut down circuit)

Operating Range (Ta = 0 to 85°C, (Note 5))

Characteristics	Symbol	Test Condition	Min	Typ.	Max	Unit
Power supply voltage	V _{DD}	—	4.5	5.0	5.5	V
Motor supply voltage	V _M	V _{DD} = 5.0 V, C _{cp1} = 0.22 μF, C _{cp2} = 0.02 μF	13	24	35	V
Output current	I _{OUT} (1)	Ta = 25°C, per phase	—	1.2	1.5	A
Logic input voltage	V _{IN}	—	GND	—	V _{DD}	V
Phase signal input frequency	f _{PHASE}	V _{DD} = 5.0 V	—	1.0	150	kHz
Chopping frequency	f _{chop}	V _{DD} = 5.0 V	50	100	150	kHz
V _{ref} reference voltage	V _{ref}	V _M = 24 V, Torque = 100%	GND	3.0	4.0	V
Current detect pin voltage	V _{RS}	V _{DD} = 5.0 V	0	±1.0	±4.5	V

Note 5: Please design in consideration of the maximum current so that T_j does not exceed 120°C.

Electrical Characteristics 1 (unless otherwise specified, Ta = 25°C, VDD = 5 V, VM = 24 V)

Characteristics		Symbol	Test Circuit	Test Condition	Min	Typ.	Max	Unit
Input voltage	HIGH	V _{IN (H)}	DC	Data input pins	2.0	V _{DD}	V _{DD} + 0.4	V
	LOW	V _{IN (L)}			GND - 0.4	GND	0.8	
Input hysteresis voltage		V _{IN (HIS)}	DC	Data input pins	200	400	700	mV
Input current		I _{IN (H)}	DC	Data input pin which contains pull-down resistance	35	50	75	μA
		I _{IN (H)}		Data input pin which contains no pull-down resistance	—	—	1.0	
		I _{IN (L)}		—	—	1.0		
Power dissipation (V _{DD} pin)		I _{DD1}	DC	V _{DD} = 5 V, all inputs connected to ground, Logic, output all off	1.0	2.0	3.0	mA
		I _{DD2}		Output OPEN, f _{PHASE} = 1.0 kHz LOGIC ACTIVE, V _{DD} = 5 V, ChargePump = charged	1.0	2.5	3.5	
Power dissipation (V _M pin)		I _{M1}	DC	Output OPEN, all inputs connected to ground, Logic, output all off, ChargePump = no operation	1.0	2.0	3.0	mA
		I _{M2}		OUT OPEN, f _{PHASE} = 1 kHz LOGIC ACTIVE, V _{DD} = 5 V, V _M = 24 V, Output off, ChargePump = charged	2.0	4.0	5.0	
		I _{M3}		OUT OPEN, f _{PHASE} = 4 kHz LOGIC ACTIVE, 100 kHz chopping (emulation), Output OPEN, ChargePump = charged	—	10	13	
Output standby current	Upper	I _{OB}	DC	V _{RS} = V _M = 24 V, V _{OUT} = 0 V, STANDBY = H, PHASE = H	-200	-150	—	μA
Output bias current	Upper	I _{OB}	DC	V _{OUT} = 0 V, STANDBY = H	-100	-50	—	μA
Output leakage current	Lower	I _{OL}	DC	V _{RS} = V _M = C _{CPA} = V _{OUT} = 24 V, LOGIC IN = ALL = L	—	—	1.0	μA
Comparator reference voltage ratio	HIGH (reference)	V _{RS (H)}	DC	V _{ref} = 3.0 V, V _{ref} (Gain) = 1/5.0 TORQUE = (H) = 100% set	—	100	—	%
	LOW	V _{RS (L)}		V _{ref} = 3.0 V, V _{ref} (Gain) = 1/5.0 TORQUE = (L) = 71% set	66	71	76	
Output current differential		ΔI _{OUT1}	DC	Differences between output current channels	-5	—	5	%
Output current setting differential		ΔI _{OUT2}	DC	I _{OUT} = 1000 mA	-5	—	5	%
RS pin current		I _{RS}	DC	V _{RS} = 24 V, V _M = 24 V STANDBY = L	—	1	2	μA
Output transistor drain-source ON-resistance		R _{ON (D-S) 1}	DC	I _{OUT} = 1.0 A, V _{DD} = 5.0 V T _J = 25°C, Drain-Source	—	0.5	0.6	Ω
		R _{ON (S-D) 1}		I _{OUT} = 1.0 A, V _{DD} = 5.0 V T _J = 25°C, Source-Drain	—	0.5	0.6	
		R _{ON (D-S) 2}		I _{OUT} = 1.0 A, V _{DD} = 5.0 V T _J = 105°C, Drain-Source	—	0.6	0.75	
		R _{ON (S-D) 2}		I _{OUT} = 1.0 A, V _{DD} = 5.0 V T _J = 105°C, Source-Drain	—	0.6	0.75	

Electrical Characteristics 2 (unless otherwise specified, $T_a = 25^\circ\text{C}$, $V_{DD} = 5\text{ V}$, $V_M = 24\text{ V}$)

Characteristics	Symbol	Test Circuit	Test Condition	Min	Typ.	Max	Unit
V_{ref} input voltage	V_{ref}	DC	$V_M = 24\text{ V}$, $V_{DD} = 5\text{ V}$, $\overline{\text{STANDBY}} = \text{H}$, Output on, $\text{PHASE} = 1\text{ kHz}$	GND	—	4.0	V
V_{ref} input current	I_{ref}	DC	$\overline{\text{STANDBY}} = \text{H}$, Output on, $V_M = 24\text{ V}$, $V_{DD} = 5\text{ V}$, $V_{ref} = 3.0\text{ V}$	20	35	50	μA
V_{ref} attenuation ratio	$V_{ref}(\text{GAIN})$	DC	$V_M = 24\text{ V}$, $V_{DD} = 5\text{ V}$, $\overline{\text{STANDBY}} = \text{H}$, Output on, $V_{ref} = 0.0\text{ to }4.0\text{ V}$	1/4.8	1/5.0	1/5.2	—
TSD temperature (Note 1)	$T_{j\text{TSD}}$	DC	$V_{DD} = 5\text{ V}$, $V_M = 24\text{ V}$	130	—	170	$^\circ\text{C}$
TSD return temperature difference (Note 1)	$\Delta T_{j\text{TSD}}$	DC	$T_{j\text{TSD}} = 130\text{ to }170^\circ\text{C}$	$T_{j\text{TSD}} - 50$	$T_{j\text{TSD}} - 35$	$T_{j\text{TSD}} - 20$	$^\circ\text{C}$
V_{DD} return voltage	V_{DDR}	DC	$V_M = 24\text{ V}$, $\overline{\text{STANDBY}} = \text{H}$	2.0	3.0	4.0	V
V_M return voltage	V_{MR}	DC	$V_{DD} = 5\text{ V}$, $\overline{\text{STANDBY}} = \text{H}$	8.0	9.0	10	V
Over current protected circuit operation current (Note 2)	ISD	—	$V_{DD} = 5\text{ V}$, $V_M = 24\text{ V}$	—	3.0	—	A

Note 1: Thermal shut down (TSD) circuit

When the IC junction temperature reaches the specified value and the TSD circuit is activated, the internal reset circuit is activated switching the outputs of both motors to off.

When the temperature is set between 130 (min) to 170 $^\circ\text{C}$ (max), the TSD circuit operates.

When the TSD circuit is activated, the charge pump is halted, and TROTECT pin outputs V_{DD} voltage.

Even if the TSD circuit is activated and $\overline{\text{STANDBY}}$ goes $\text{H} \rightarrow \text{L} \rightarrow \text{H}$ instantaneously, the IC is not reset until the IC junction temperature drops -20°C (typ.) below the TSD operating temperature (hysteresis function).

Note 2: Overcurrent protection circuit

When current exceeding the specified value flows to the output, the internal reset circuit is activated, and the ISD turns off the output.

Until the $\overline{\text{STANDBY}}$ signal goes Low to High, the overcurrent protection circuit remains activated.

During ISD, IC turns $\overline{\text{STANDBY}}$ mode and the charge pump halts.

AC Electrical Characteristics (Ta = 25°C, VM = 24 V, VDD = 5 V, 6.8 mH/5.7 Ω)

Characteristics	Symbol	Test Circuit	Test Condition	Min	Typ.	Max	Unit
Clock frequency	fPHASE	AC	—	—	—	166	kHz
Minimum Clock Pulse Width	tw (tCLK)	—	—	100	—	—	ns
	twp	—	—	50	—	—	
	twn	AC	—	50	—	—	
Output transistor switching characteristic	tr	—	Output Load: 6.8 mH/5.7 Ω	—	100	—	ns
	tf	—	—	—	100	—	
	tpLH	—	PHASE to OUT	—	1000	—	
	tpHL	—	Output Load: 6.8 mH/5.7 Ω	—	2000	—	
	tpLH	—	CR to OUT	—	500	—	
	tpHL	—	Output Load: 6.8 mH/5.7 Ω	—	1000	—	
Noise rejection dead band time	tBRANK	—	IOUT = 1.0 A	200	300	500	ns
CR reference signal oscillation frequency	fCR	—	Cosc = 560 pF, Rosc = 3.6 kΩ	—	800	—	kHz
Chopping frequency possible range	fchop (min)	—	VM = 24 V, VDD = 5 V, Output ACTIVE (IOUT = 1.0 A) Step fixed, Ccp1 = 0.22 μF, Ccp2 = 0.022 μF	40	100	150	kHz
	fchop (max)						
Chopping set frequency	fchop	—	Output ACTIVE (IOUT = 1.0 A), CR CLK = 800 kHz	—	100	—	kHz
Charge pump rise time	tONG	—	Ccp1 = 0.22 μF, Ccp2 = 0.022 μF VM = 24 V, VDD = 5 V, STANDBY = L → H	—	100	200	μs

Not Recommended for New

Current Waveform and Setting of MIXED DECAY MODE

To control the constant current, the rate of Mixed Decay Mode which determines current amplitude (ripple current) should be 37.5%.

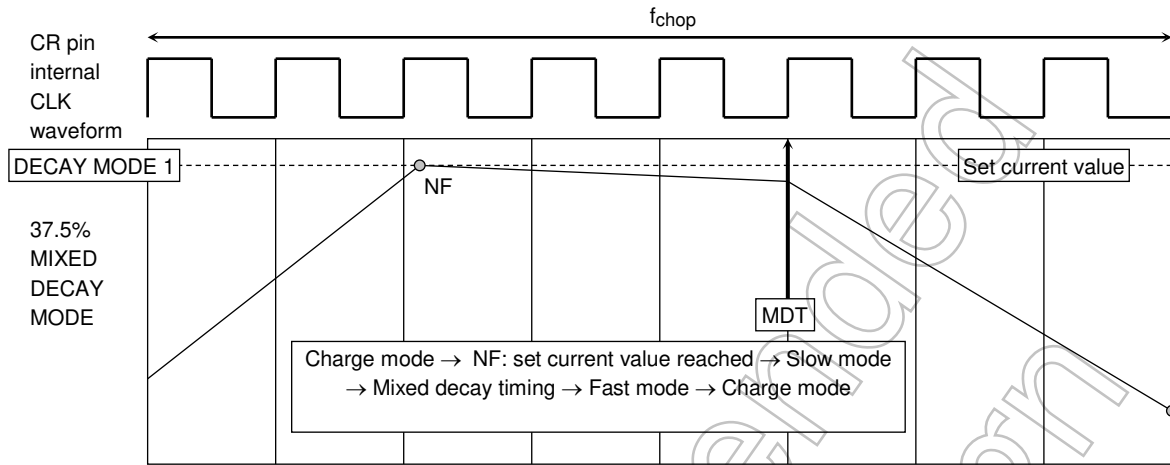

MIXED DECAY MODE Waveform (current waveform)

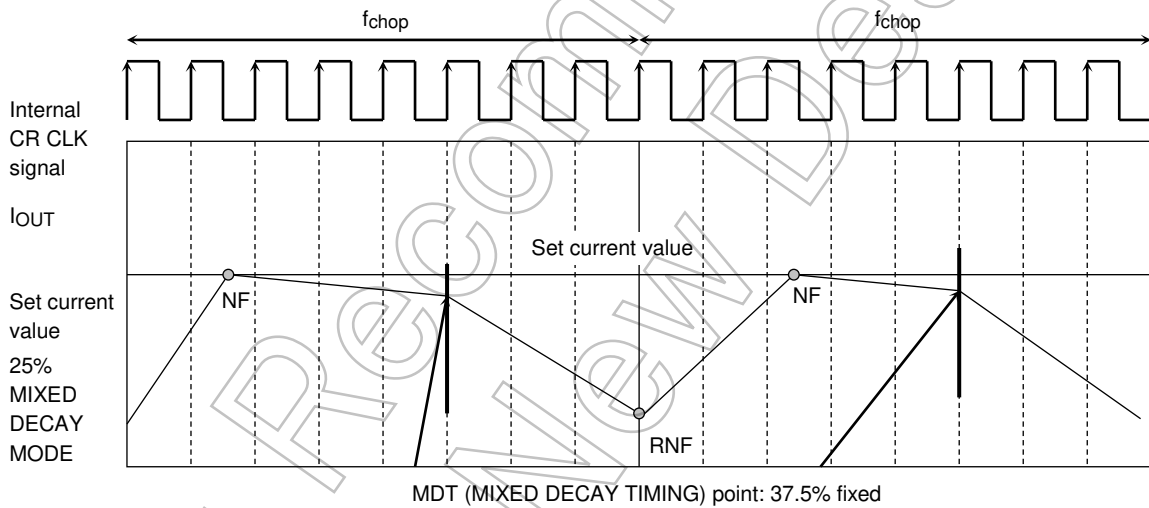

**PHASE Signal, Internal CR CLK, and Output Current Waveform
(when PHASE signal is input in 2 phase excitation mode)**

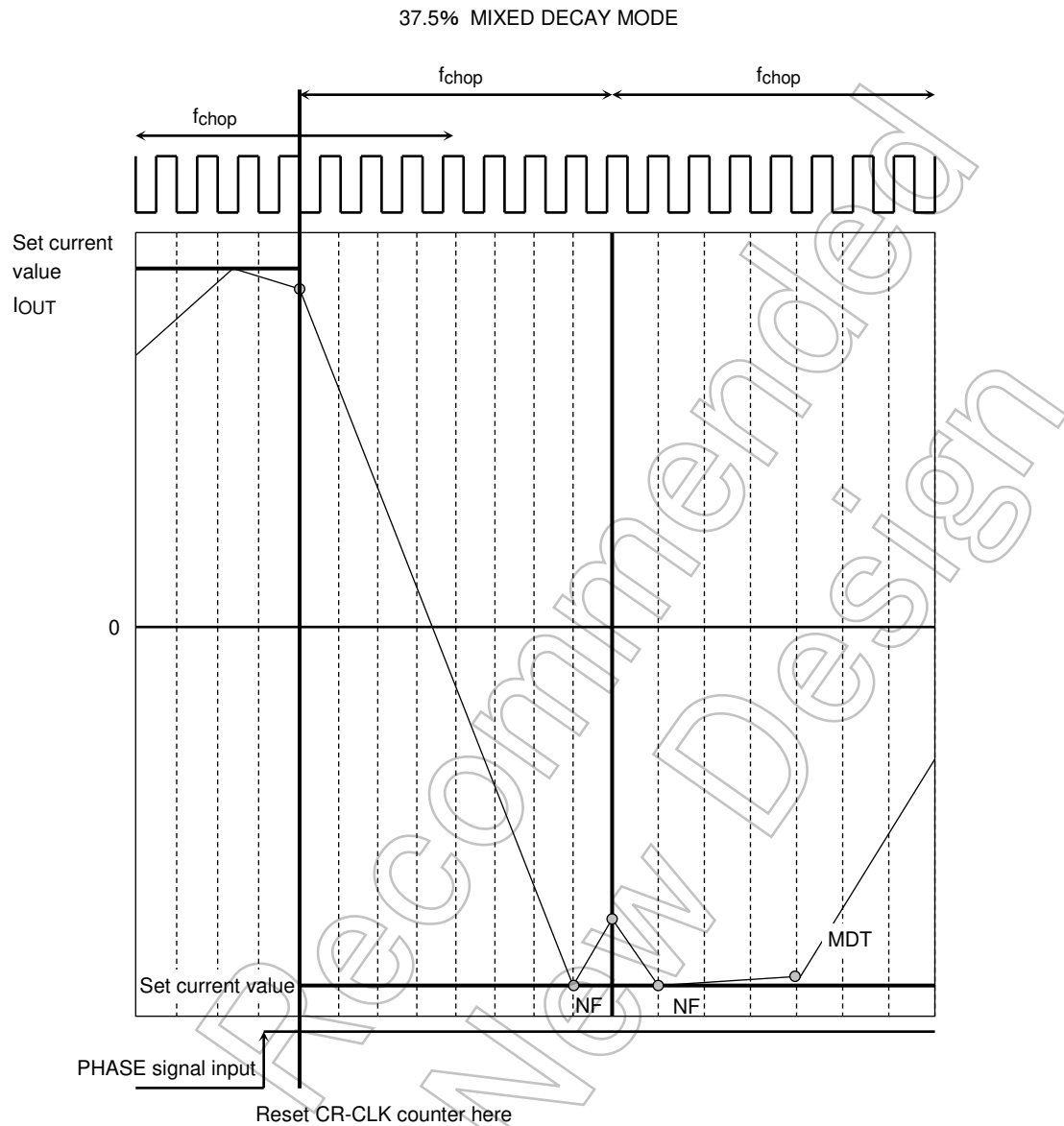

Current Discharge Path when ENABLE Input During Operation

In Slow Mode, when all output transistors are forced to switch off, coil energy is discharged in the following MODES:

Note: Parasitic diodes are located on dotted lines. In normal MIXED DECAY MODE, the current does not flow to the parasitic diodes.

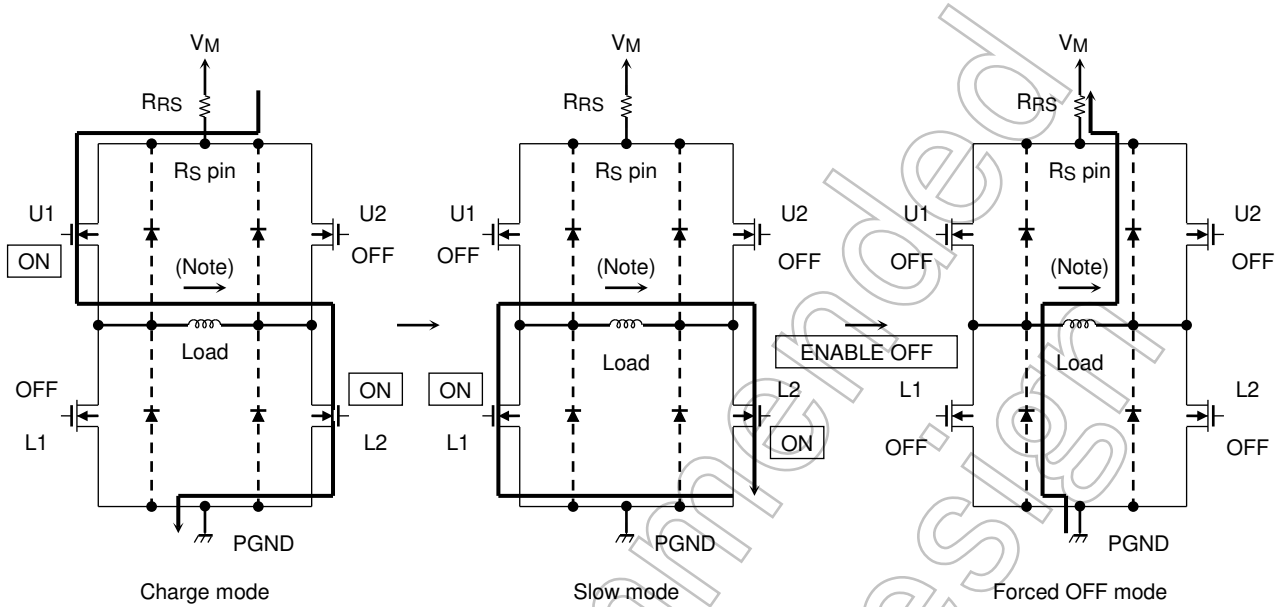

As shown in the figure above, an output transistor has parasitic diodes.

To discharge energy from the coil, each transistor is switched on allowing current to flow in the reverse direction to that in normal operation. As a result, the parasitic diodes are not used. If all the output transistors are forced to switch off, the energy of the coil is discharged via the parasitic diodes.

Output Transistor Operating Mode

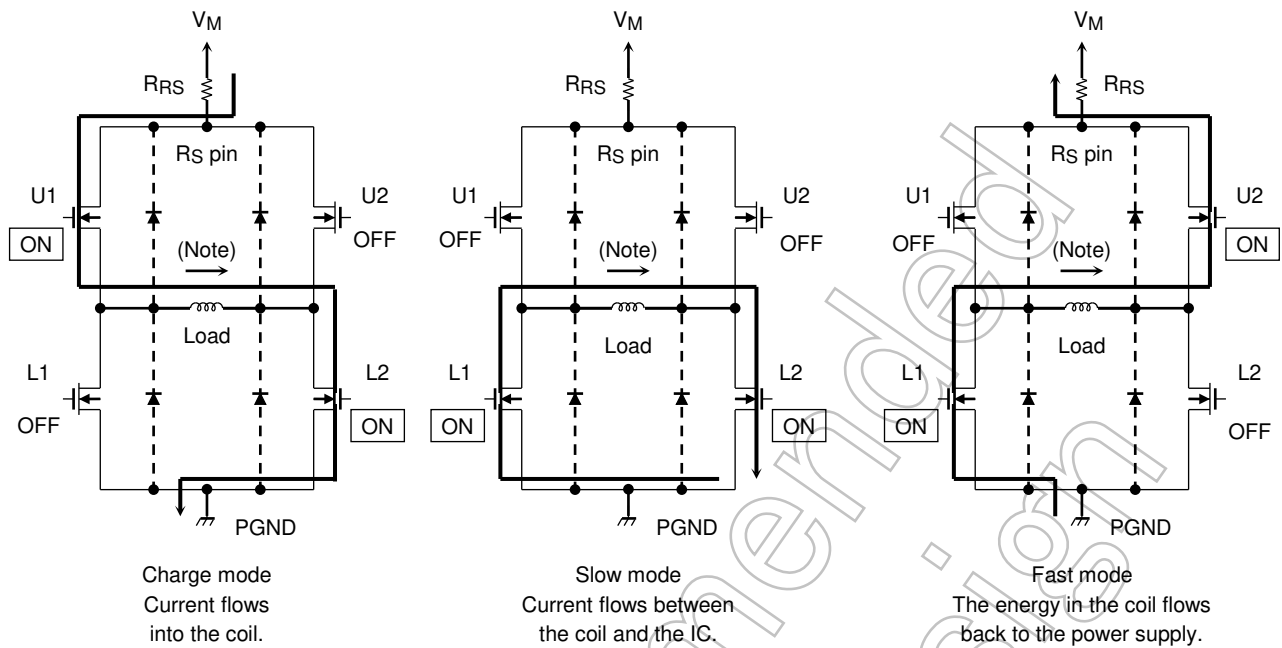

Output Transistor Operation Functions

Mode \ Tr	U1	U2	L1	L2
CHARGE	ON	OFF	OFF	ON
SLOW	OFF	OFF	ON	ON
FAST	OFF	ON	ON	OFF

Note: The above table is an example where current flows in the direction of the arrows in the above figures. When the current flows in the opposite direction of the arrows, see the table below.

Mode \ Tr	U1	U2	L1	L2
CHARGE	OFF	ON	ON	OFF
SLOW	OFF	OFF	ON	ON
FAST	ON	OFF	OFF	ON

In this IC, three modes as shown above are automatically switched to control the constant current.

Power Supply Sequence (recommended)

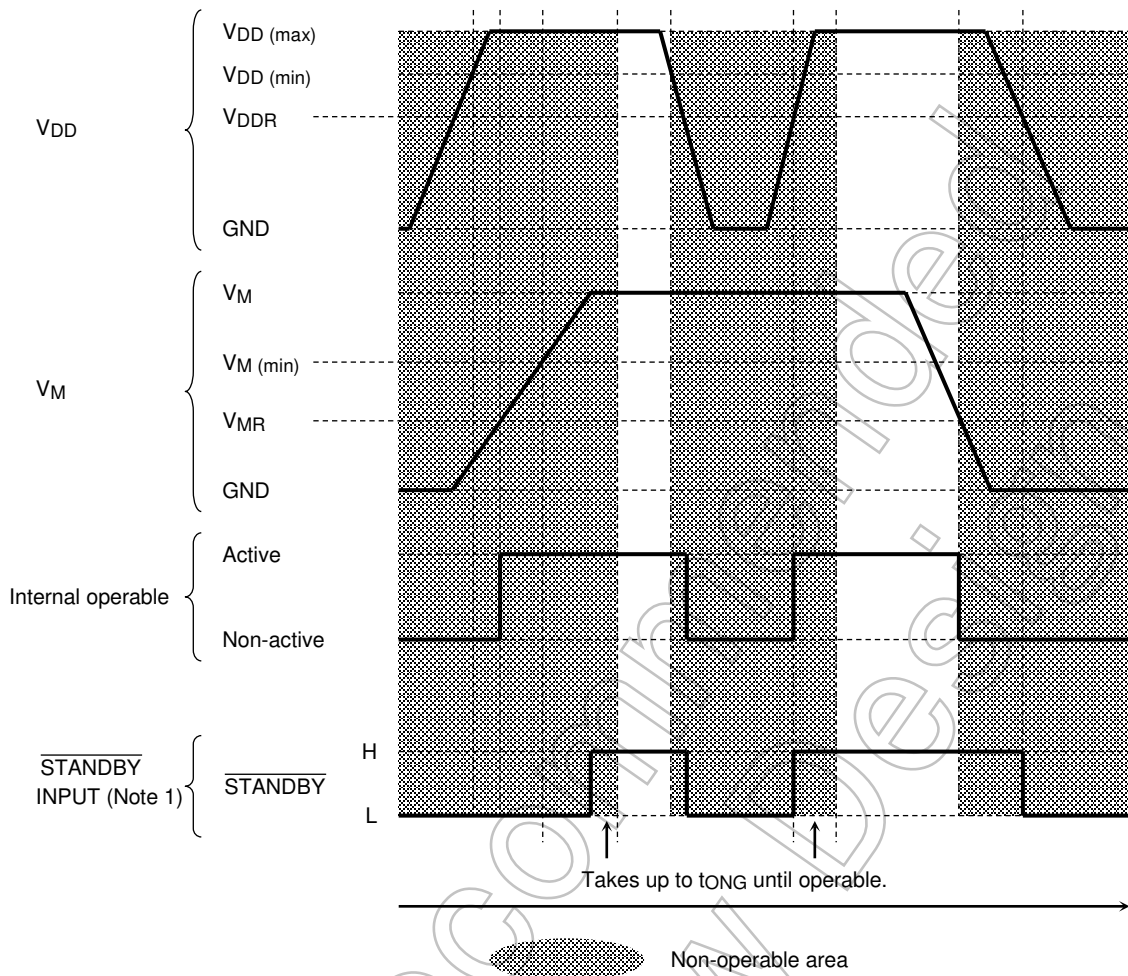

Note 1: If the VDD drops to the level of the VDDR or below while the specified voltage is input to the VM pin, the IC is internally reset.

This is a protective measure against malfunction. Likewise, if the VM drops to the level of the VMR or below while regulation voltage is input to the VDD, the IC is internally reset as a protective measure against malfunction.

To avoid malfunction, when turning on VM or VDD, to input the $\overline{\text{STANDBY}}$ signal at the above timing is recommended.

It takes time for the output control charge pump circuit to stabilize. Wait up to tONG time after power on before driving the motors.

Note 2: When the VM value is between 8 to 11 V, the internal reset is released, thus output may be on. In such a case, the charge pump cannot drive stably because of insufficient voltage. The Standby state should be maintained until VM reaches 13 V or more.

Note 3: Since VDD = 0 V and VM = voltage within the rating are applied, output is turned off by internal reset.

At that time, a current of several mA flows due to the Pass between VM and VDD.

When voltage increases on VDD output, make sure that specified voltage is input.

How to Calculate Set Current

This IC drives the motor, controlling the PWM constant current in reference to the frequency of CR oscillator.

At that time, the maximum current value (set current value) can be determined by setting the sensing resistor (R_{RS}) and reference voltage (V_{ref}).

$$I_{OUT(max)} = \frac{1}{5.0} \times V_{ref} (V) \times \frac{\text{Torque (Torque = 100, 71\%)}}{R_{RS} (\Omega) \times 100(\%)}$$

1/5.0 is V_{ref} (gain): V_{ref} attenuation ratio. (for the specifications, see the electrical characteristics.)

For example, when applying $V_{ref} = 3$ V and torque = 100% to drive out I_{OUT} of 0.8 A, $R_{RS} = 0.75 \Omega$ (0.5 W or more) is required.

(for 1-2 phase excitation with 71% of torque, the peak current should be set to 100%).

How to Calculate the Chopping and OSC Frequencies

At constant current control, this IC chops frequency using the oscillation waveform (saw tooth waveform) determined by external capacitor and resistor as a reference.

The TB62206FG requires an oscillation frequency of eight times the chopping frequency.

The oscillation frequency is calculated as follows:

$$f_{CR} = \frac{1}{0.523 \times (C \times R + 600 \times C)}$$

For example, when $C_{osc} = 560$ pF and $R_{osc} = 3.6$ k Ω are connected, $f_{CR} = 813$ kHz.

At this time, the chopping frequency f_{chop} is calculated as follows:

$$f_{chop} = f_{CR}/8 = 101 \text{ kHz}$$

IC Power Dissipation

IC power dissipation is classified into two: power consumed by transistors in the output block and power consumed by the logic block and the charge pump circuit.

- Power consumed by the Power Transistor (calculated with $R_{ON} = 0.60 \Omega$)
- In Charge mode, Fast Decay mode, or Slow Decay mode, power is consumed by the upper and lower transistors of the H bridges.

The following expression expresses the power consumed by the transistors of a H bridge.

$$P(\text{out}) = 2 (T_r) \times I_{OUT} (\text{A}) \times V_{DS} (\text{V}) = 2 \times I_{OUT}^2 \times R_{ON} \dots\dots\dots (1)$$

The average power dissipation for output under 4-bit micro step operation (phase difference between phases A and B is 90°) is determined by expression (1).

Thus, power dissipation for output per unit is determined as follows (2) under the conditions below.

- $R_{ON} = 0.60 \Omega$ (@ 1.0 A)
- $I_{OUT} (\text{Peak: max}) = 1.0 \text{ A}$
- $V_M = 24 \text{ V}$
- $V_{DD} = 5 \text{ V}$

$$P(\text{out}) = 2 (T_r) \times 1.0^2 (\text{A}) \times 0.60 \times 2 (\Omega) = 2.40 (\text{W}) \dots\dots\dots (2)$$

Power consumed by the logic block and IM

The following standard values are used as power dissipation of the logic block and IM at operation.

- $I (\text{LOGIC}) = 2.5 \text{ mA (typ.)}$:
- $I (I_{M3}) = 10.0 \text{ mA (typ.)}$: operation/unit
- $I (I_{M1}) = 2.0 \text{ mA (typ.)}$: stop/unit

The logic block is connected to V_{DD} (5 V). IM (total of current consumed by the circuits connected to V_M and current consumed by output switching) is connected to V_M (24 V). Power dissipation is calculated as follows:

$$P(\text{Logic\&IM}) = 5 (\text{V}) \times 0.0025 (\text{A}) + 24 (\text{V}) \times 0.010 (\text{A}) = 0.25 (\text{W}) \dots\dots\dots (3)$$

Thus, the total power dissipation (P) is

$$P = P(\text{out}) + P(\text{Logic\&IM}) = 2.65 (\text{W})$$

Power dissipation at standby is determined as follows:

$$P(\text{standby}) + P(\text{out}) = 24 (\text{V}) \times 0.002 (\text{A}) + 5 (\text{V}) \times 0.0025 (\text{A}) = 0.06 (\text{W})$$

For thermal design on the board, evaluate by mounting the IC.

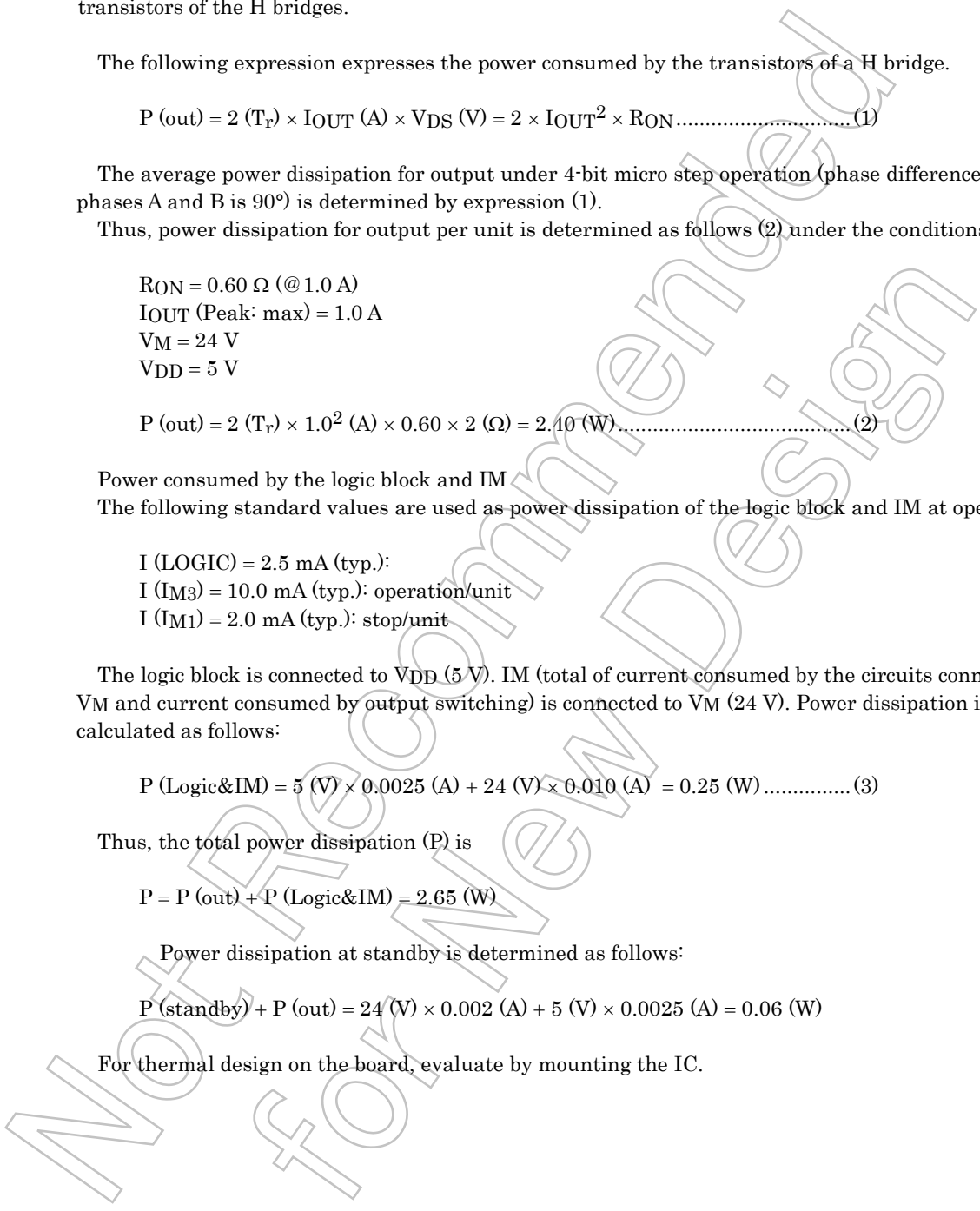

Test Waveforms

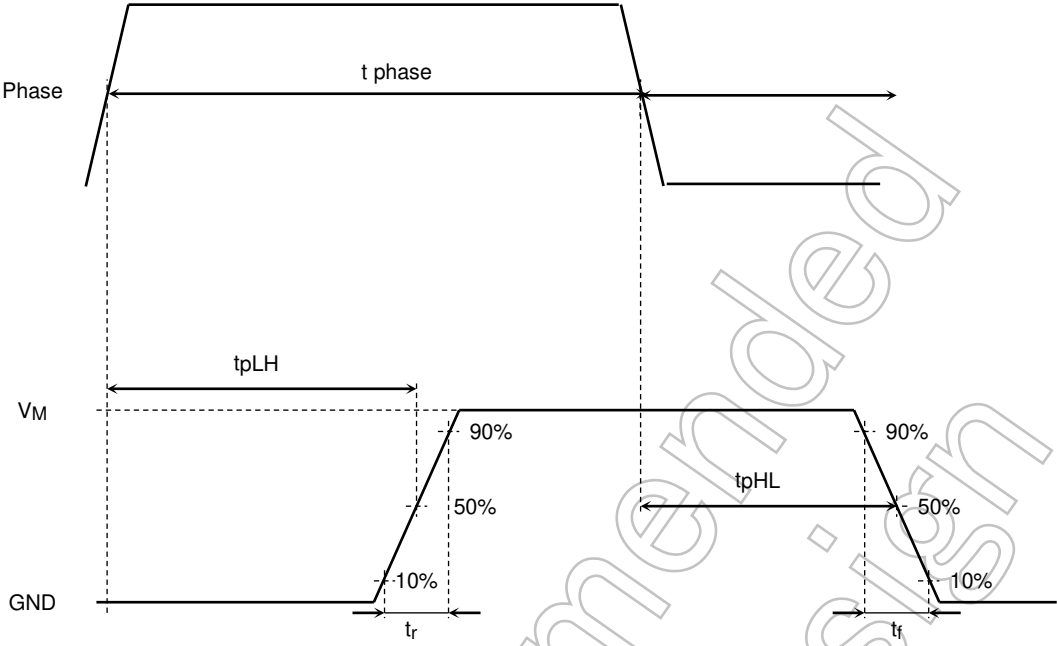
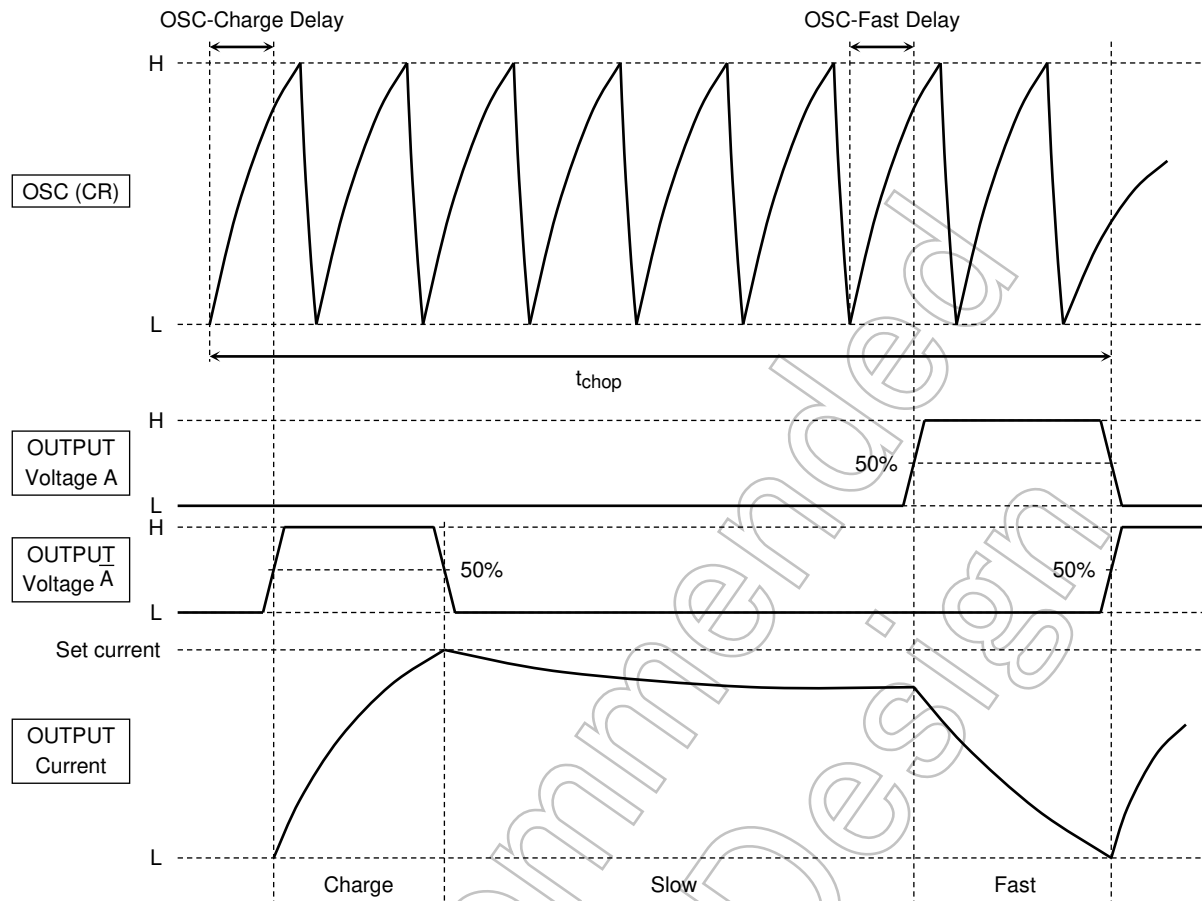

Figure 1 Timing Waveforms and Names

Not Recommended for New Design



OSC-Charge DELAY:

Because the rising edge level of the OSC waveform is used for converting the OSC waveform to the internal CR CLK, a delay of up to 1.25 ns (@ $f_{chop} = 100$ kHz: $f_{CR} = 400$ kHz) occurs between the OSC waveform and the internal CR CLK.

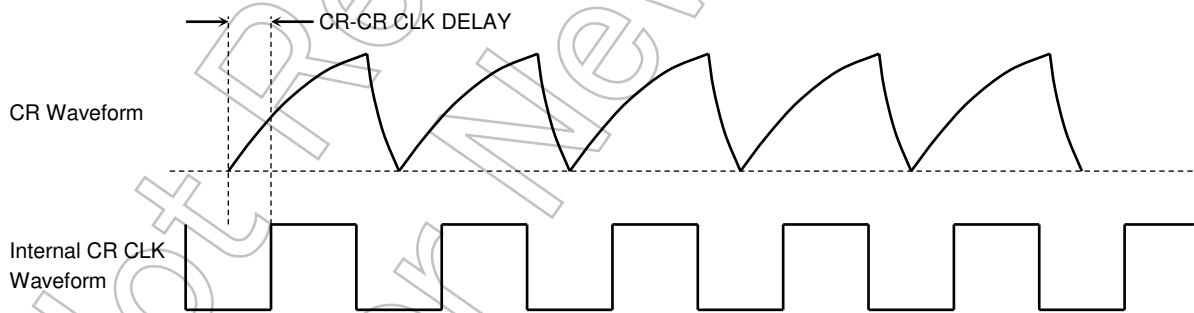
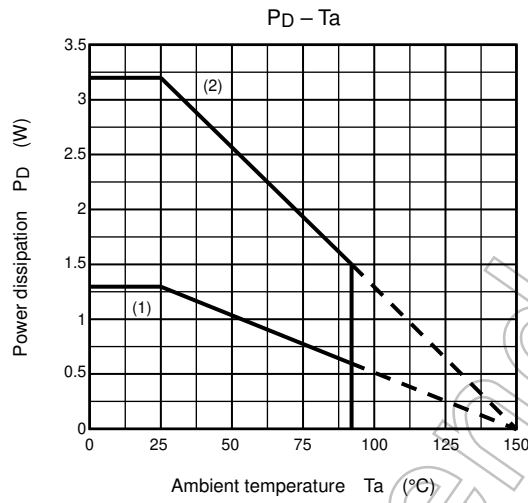

Figure 2 Timing Waveforms and Names (CR and output)

PD – Ta (package power dissipation)



(4) HSOP20 Rth (j-a) only (96°C/W)

(5) When mounted on the board (140 mm × 70 mm × 1.6 mm: 38°C/W: typ.: under evaluation)

Note: Rth (j-c): 8.5°C/W

Transient thermal resistance at soldering process depends on the PCB condition to be used. Please pay attention to the thermal conditions when designing PCB, and be sure to check the thermal conditions at the actual evaluation.

Not Recommended for New Design

Relationship between VM and VH (charge pump voltage)

Note: VDD = 5 V

VM – VH (&Vcharge UP)

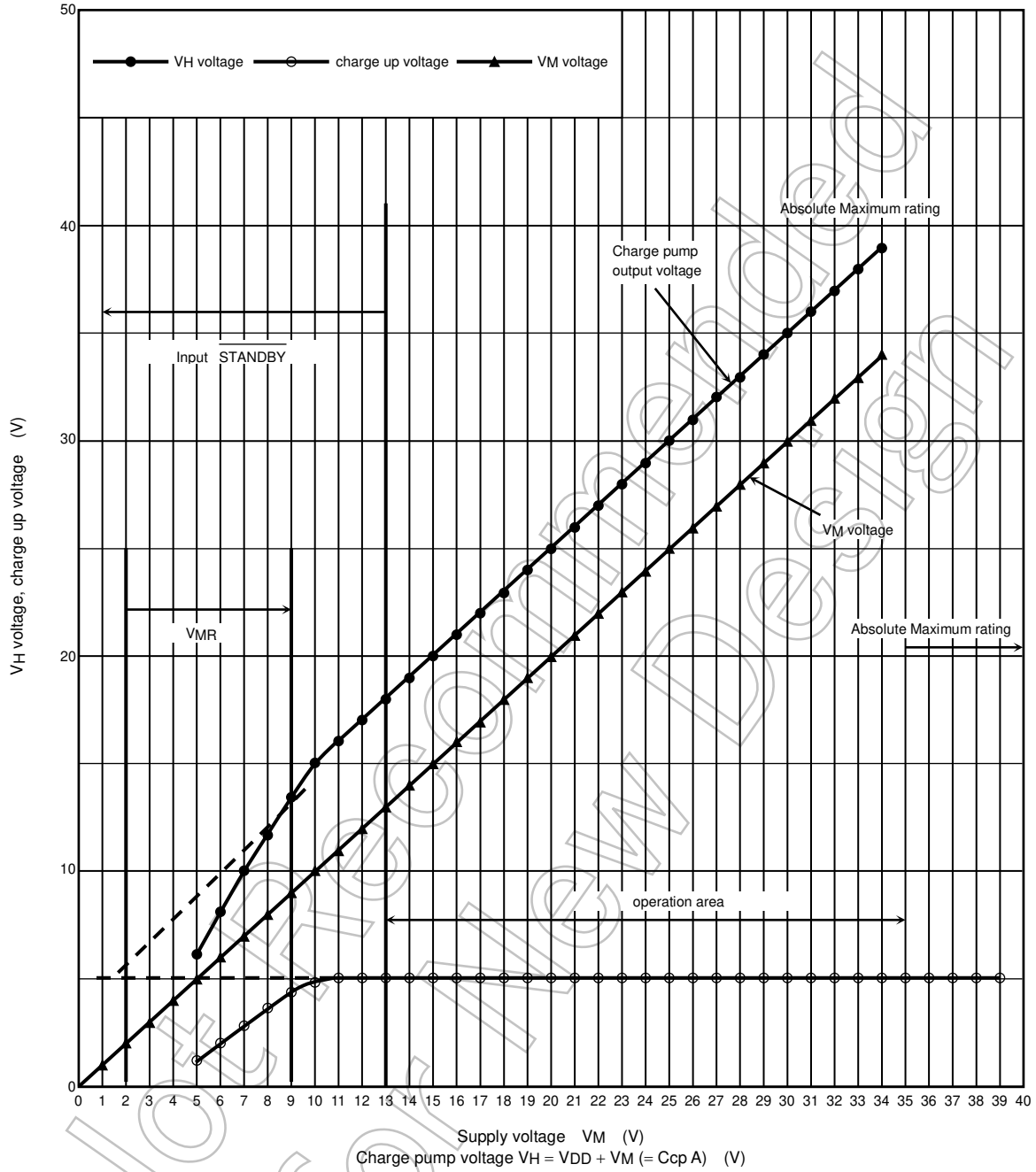

Operation of Charge Pump Circuit

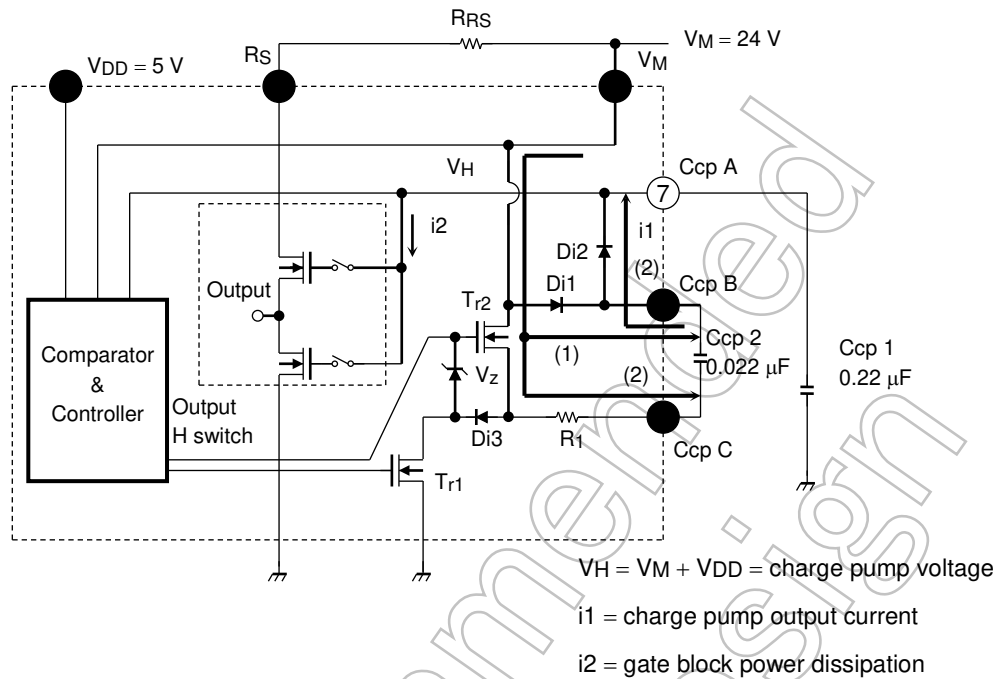

- Initial charging
 - (1) When RESET is released, T_{R1} is turned ON and T_{R2} turned OFF. Ccp 2 is charged from Ccp 2 via Di1.
 - (2) T_{R1} is turned OFF, T_{R2} is turned ON, and Ccp 1 is charged from Ccp 2 via Di2.
 - (3) When the voltage difference between V_M and V_H (Ccp A pin voltage = charge pump voltage) reaches V_{DD} or higher, operation halts (steady state).
- Actual operation
 - (4) Ccp 1 charge is used at f_{chop} switching and the V_H potential drops.
 - (5) Charges up by (1) and (2) above.

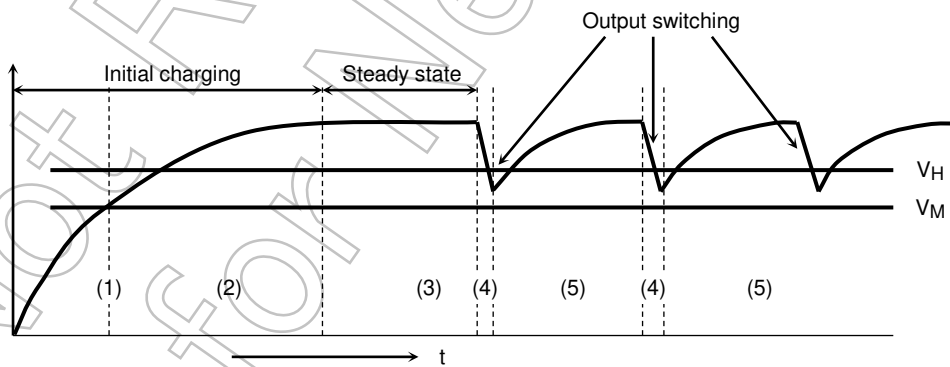

Charge Pump Rise Time

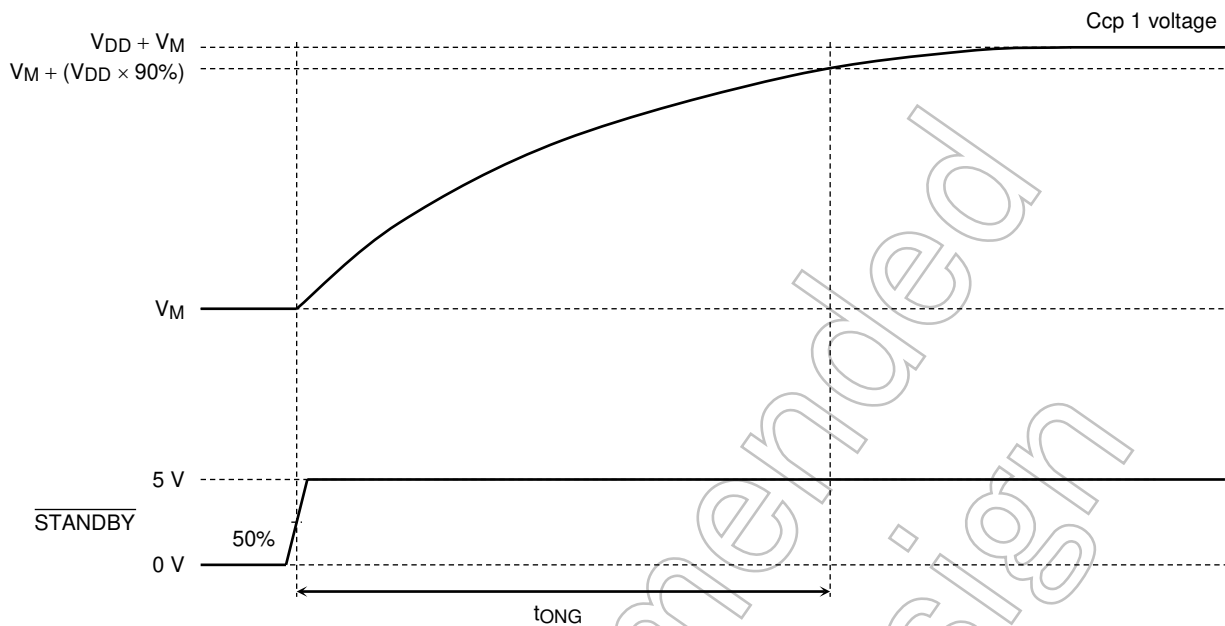

t_{ONG} :

Delay time taken for capacitor Ccp 2 (charging capacitor) to fill up Ccp 1 (storing capacitor) to $V_M + V_{DD}$ after $\overline{STANDBY}$ is released.

The internal IC cannot drive the gates correctly until the voltage of Ccp 1 reaches $V_M + V_{DD}$. Be sure to wait for t_{ONG} or longer before driving the motors.

Basically, the larger the Ccp 1 capacitance, the smaller the voltage fluctuation, though the initial charge up time is longer.

The smaller the Ccp 1 capacitance, the shorter the initial charge-up time but the voltage fluctuation is larger.

Depending on the combination of capacitors (especially with small capacitance), voltage may not be sufficiently boosted.

When the voltage does not increase sufficiently, output DMOS R_{ON} turns lower than the normal, and it raises the temperature.

Thus, use the capacitors under the capacitor combination conditions (Ccp 1 = 0.22 μF , Ccp 2 = 0.022 μF) recommended by Toshiba.

Overcurrent Shutdown (ISD) Circuitry

ISD Dead Time and ISD On-Time

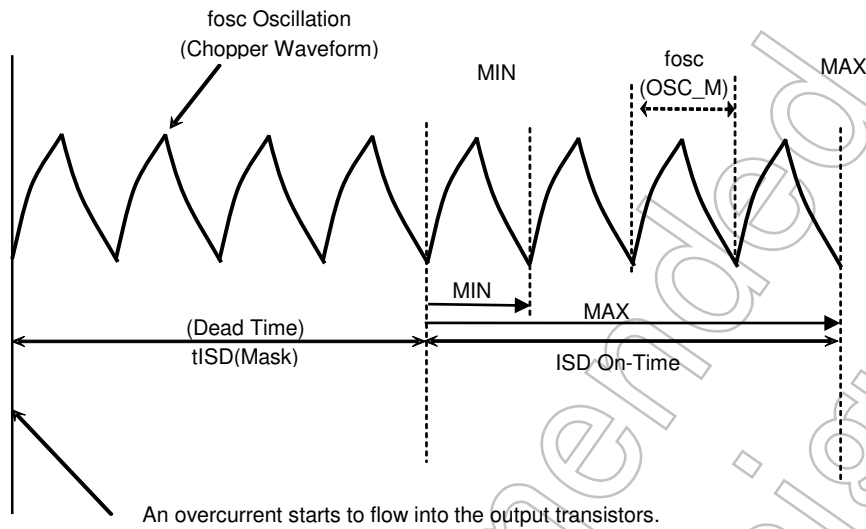

Figure for reference: Timing chart in case the over current flows in the motor.

The overcurrent shutdown (ISD) circuitry has a dead time to prevent false detection by the spike current in switching. The dead time synchronizes with the frequency of OSC (OSC_M) for configuration of chopping frequency. It is configured as follows.

Time from the flow of the over current to the output steps to the stop of the output is as follows.

Dead time = $4 \times f_{osc_M}$ frequency

In setting,

Min: $4 \times f_{osc_M}$ frequency

Max: $8 \times f_{osc_M}$ frequency (+ Synchronizing time + $1 f_{osc_M}$ time)

It should be noted that these values assume a case in which an overcurrent condition is detected in an ideal manner. The ISD circuitry might not work, depending on the control timing of the output transistors.

Therefore, a protection fuse must always be added to the V_M power supply as a safety precaution. The optimal fuse capacitance varies with usage conditions, and one that does not adversely affect the motor operation or exceed the power dissipation rating of the TB62206FG should be selected.

Not for

External Capacitor for Charge Pump

When driving the stepping motor with $V_{DD} = 5\text{ V}$, $f_{chop} = 150\text{ kHz}$, $L = 10\text{ mH}$ under the conditions of $V_M = 13\text{ V}$ and 1.5 A , the logical values for Ccp 1 and Ccp 2 are as shown in the graph below:

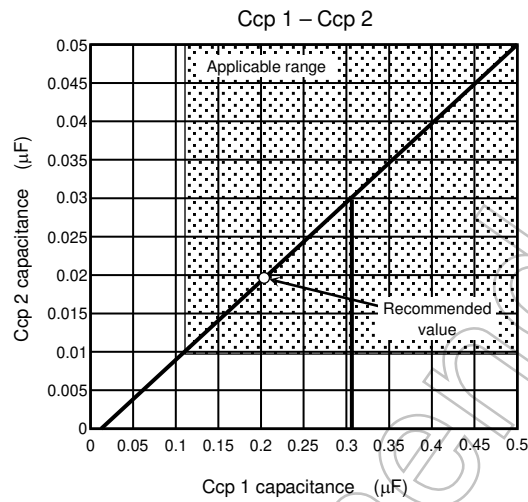

Choose Ccp 1 and Ccp 2 to be combined from the above applicable range. We recommend Ccp 1 : Ccp 2 at 10 : 1 or more. (if our recommended values (Ccp 1 = 0.22 μF, Ccp 2 = 0.022 μF) are used, the drive conditions in the specification sheet are satisfied. (there is no capacitor temperature characteristic as a condition.)

When setting the constants, make sure that the charge pump voltage is not below the specified value and set the constants with a margin (the larger Ccp 1 and Ccp 2, the more the margin).

Some capacitors exhibit a large change in capacitance according to the temperature. Make sure the above capacitance is obtained under the usage environment temperature.

Not Recommended for New Design

Driving Mode

2-Phase Excitation Mode

In 2-Phase Excitation, ENABLE is always High

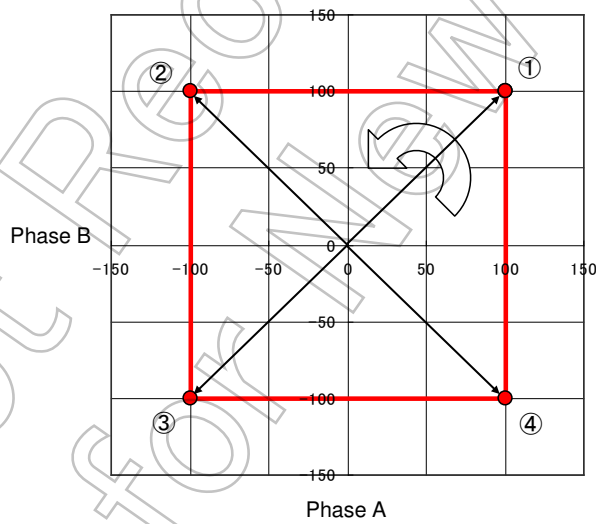
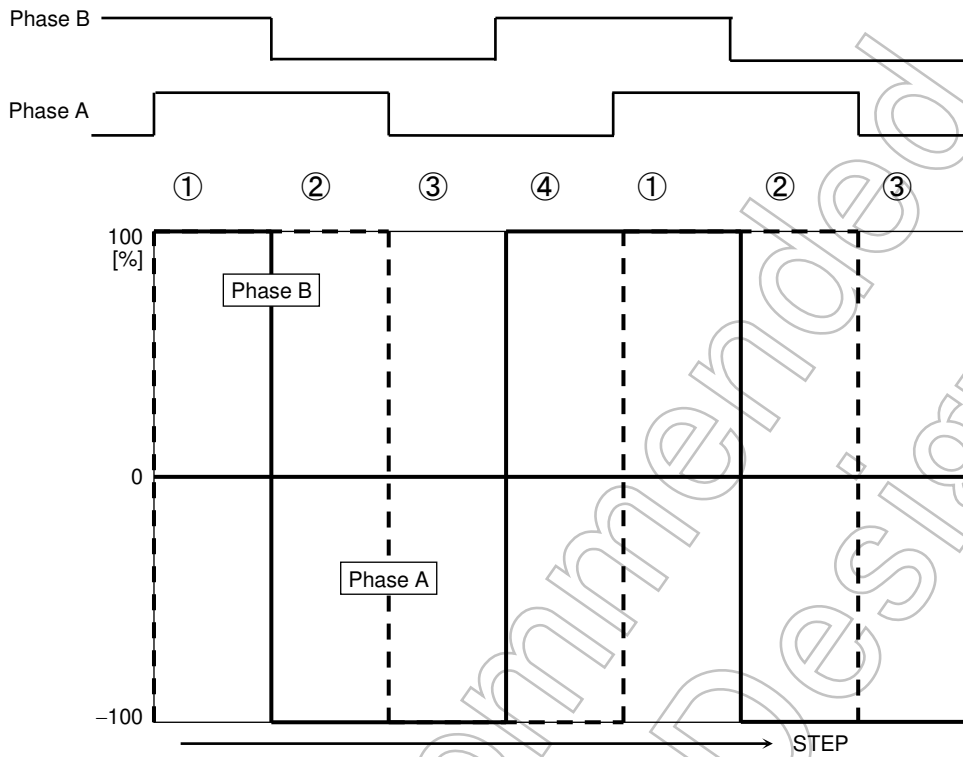

1-2 Phase Excitation

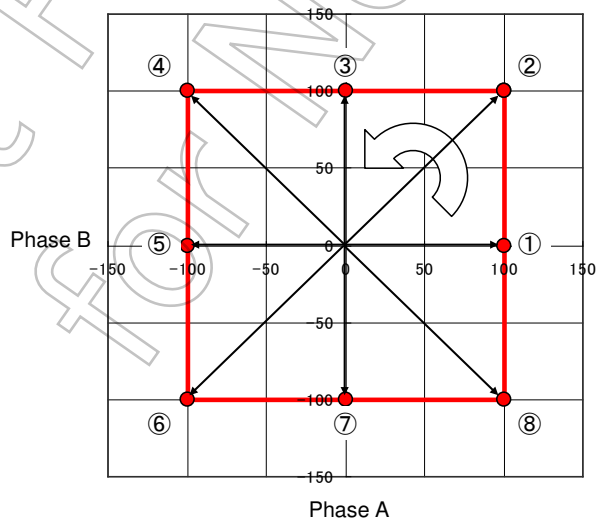
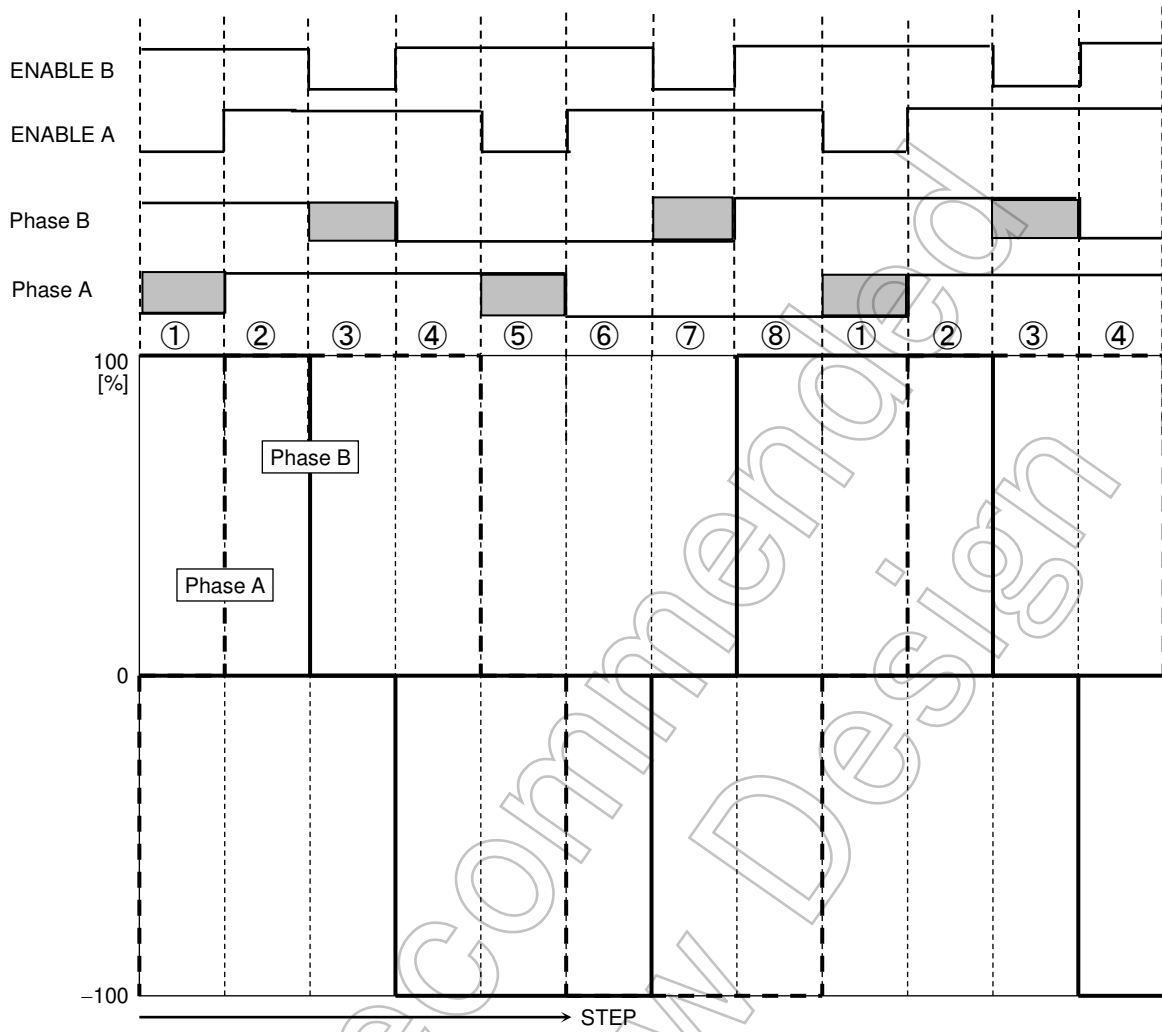

Sequence examples including reverse (1/2 step)

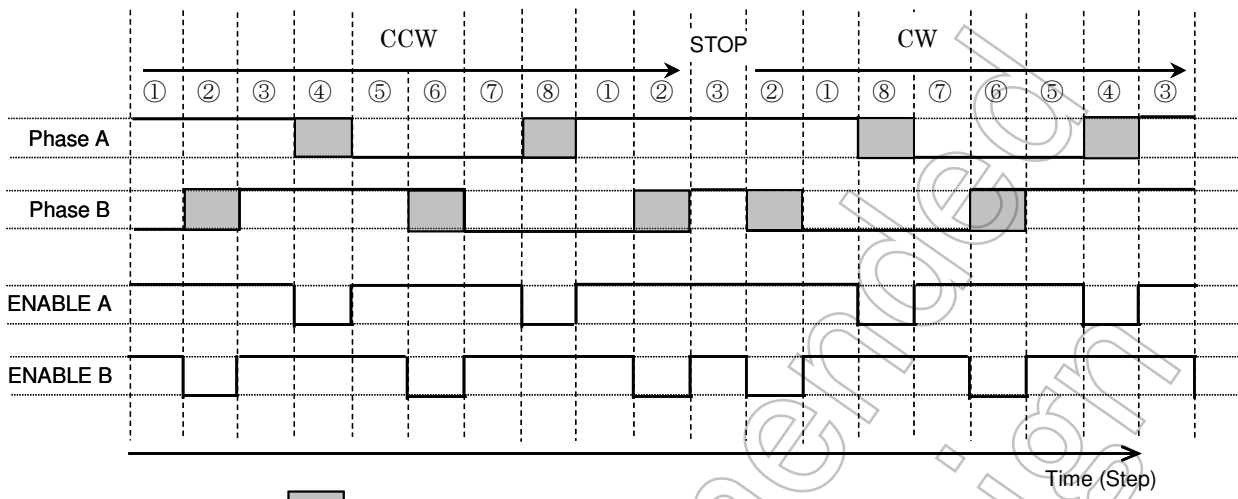

■ : Don't Care

● Electrical angle representation of the sequence

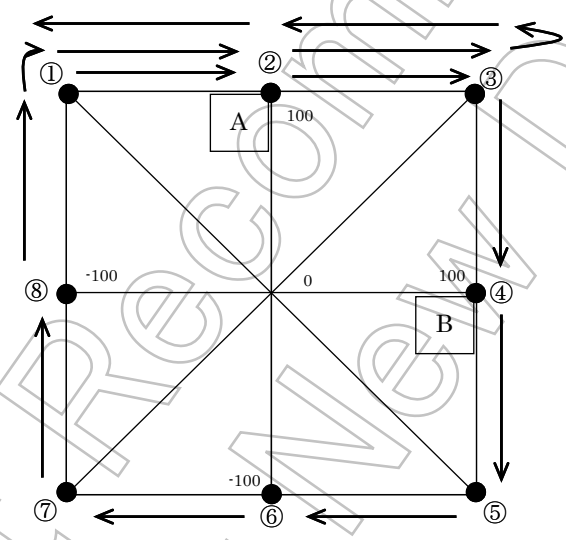

Step proceeded to ①→②.. ⑦→⑧ → ① → ② → ③ , and is reversed. This is an example of progress to ③→②→①→⑧..④→③. Second time ③ is a reversal point.

Not for

Application Circuit (example)

The values for the respective devices are all recommended values. For values under each input condition, see the above-mentioned recommended operating conditions.

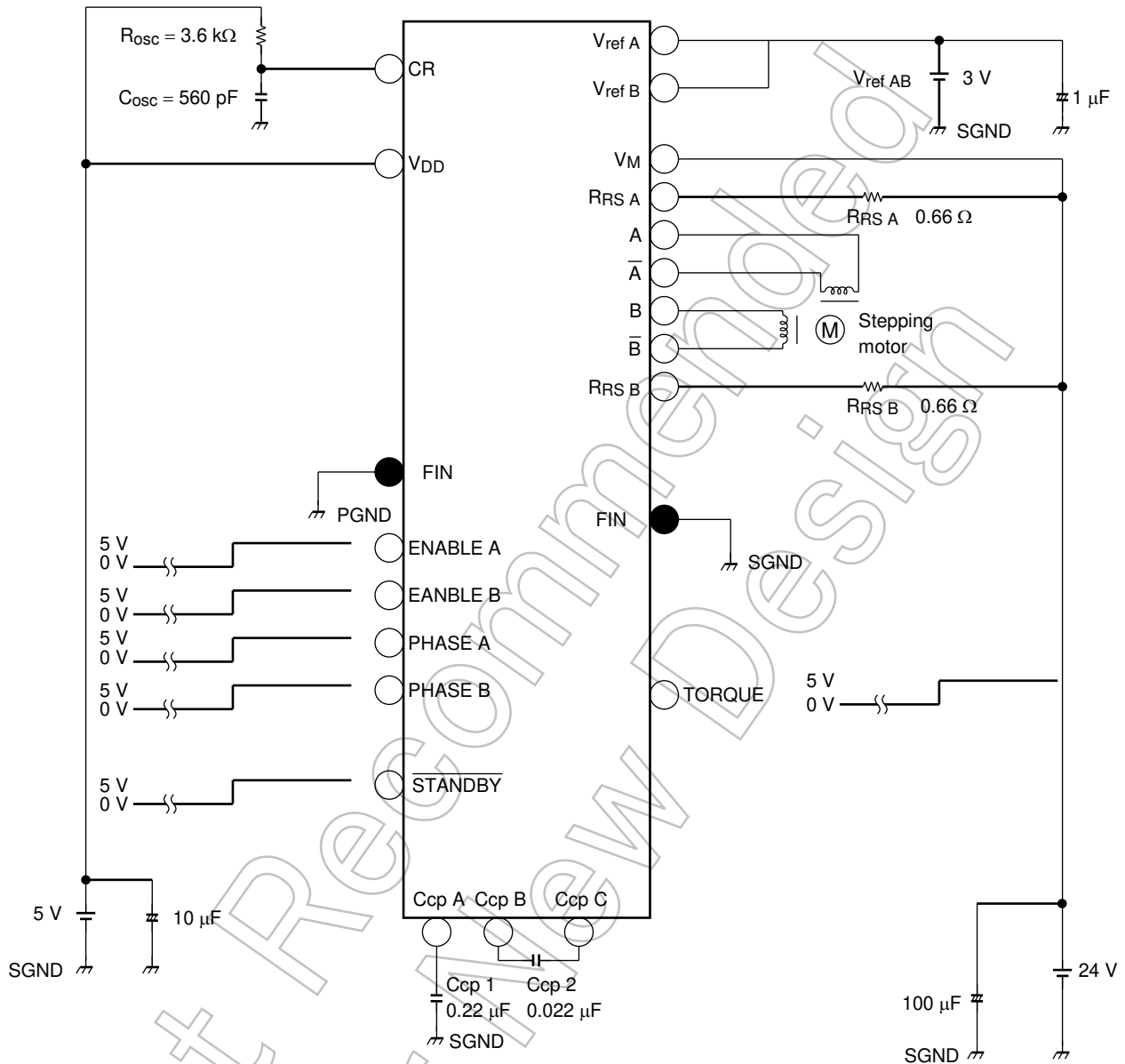

Note: Adding bypass capacitors is recommended.
 Make sure that GND wiring has only one contact point, and to design the pattern that allows the heat radiation.
 To control setting pins in each mode by SW, make sure to pull down or pull up them to avoid high impedance.
 To input the data, see the section on the recommended input data.

The IC may be destroyed due to short circuit between output pins, an output pin and the VDD pin, or an output pin and the GND pin.
 Design an output line, VDD (VM) line and GND line with great care.
 Also a low-withstand-voltage device may be destroyed when mounted in the wrong orientation, which causes high-withstanding voltage to be applied to the device.

Package Dimensions

HSOP20-P-450-1.00

Unit : mm

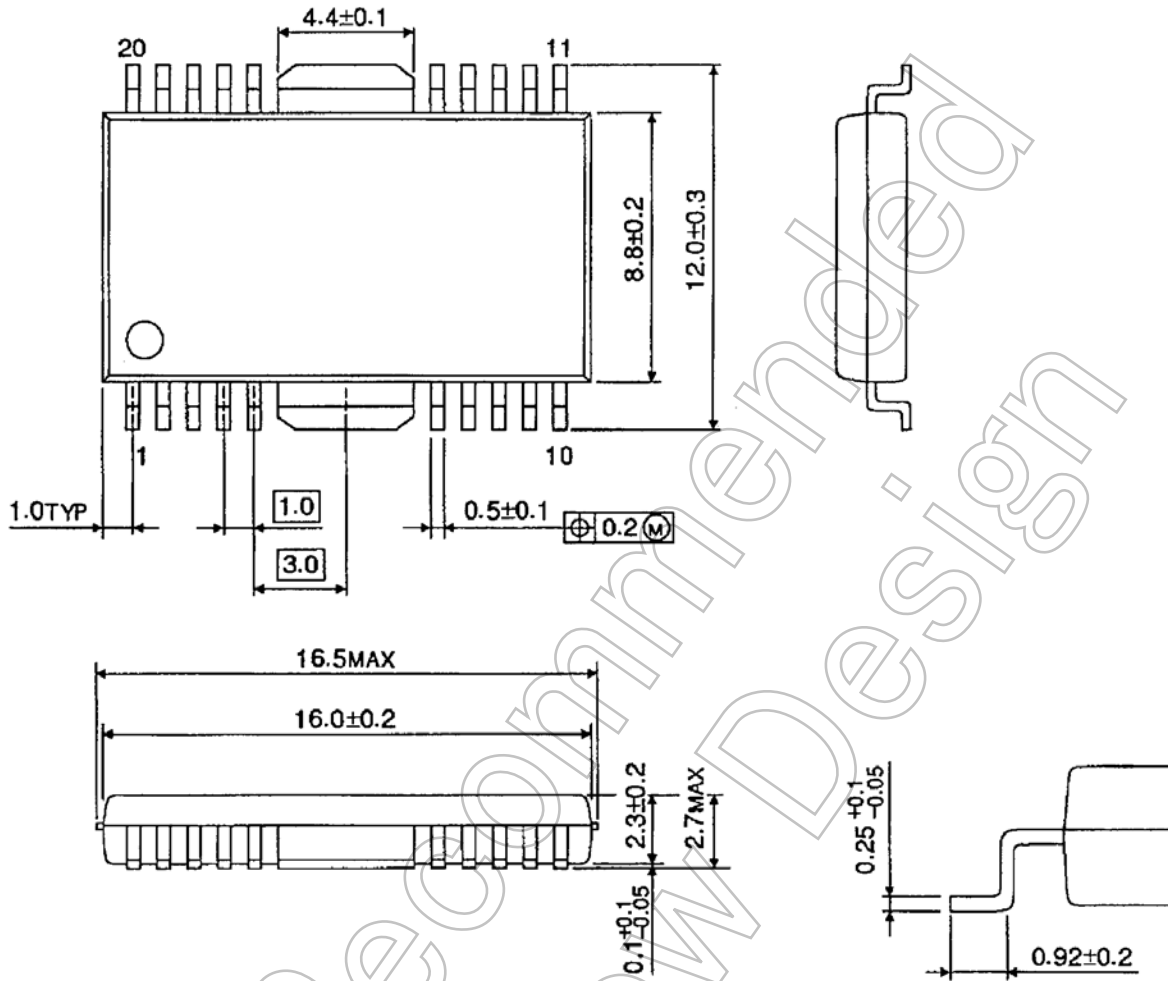

Weight: 0.79 g (typ.)

Not Recommended for New Design

Notes on Contents

1. Block Diagrams

Some of the functional blocks, circuits, or constants in the block diagram may be omitted or simplified for explanatory purposes.

2. Equivalent Circuits

The equivalent circuit diagrams may be simplified or some parts of them may be omitted for explanatory purposes.

3. Timing Charts

Timing charts may be simplified for explanatory purposes.

4. Application Circuits

The application circuits shown in this document are provided for reference purposes only. Thorough evaluation is required, especially at the mass production design stage.

Toshiba does not grant any license to any industrial property rights by providing these examples of application circuits.

5. Test Circuits

Components in the test circuits are used only to obtain and confirm the device characteristics. These components and circuits are not guaranteed to prevent malfunction or failure from occurring in the application equipment.

IC Usage Considerations

Notes on handling of ICs

- [1] The absolute maximum ratings of a semiconductor device are a set of ratings that must not be exceeded, even for a moment. Do not exceed any of these ratings.
Exceeding the rating(s) may cause the device breakdown, damage or deterioration, and may result injury by explosion or combustion.
- [2] Use an appropriate power supply fuse to ensure that a large current does not continuously flow in case of over current and/or IC failure. The IC will fully break down when used under conditions that exceed its absolute maximum ratings, when the wiring is routed improperly or when an abnormal pulse noise occurs from the wiring or load, causing a large current to continuously flow and the breakdown can lead smoke or ignition. To minimize the effects of the flow of a large current in case of breakdown, appropriate settings, such as fuse capacity, fusing time and insertion circuit location, are required.
- [3] If your design includes an inductive load such as a motor coil, incorporate a protection circuit into the design to prevent device malfunction or breakdown caused by the current resulting from the inrush current at power ON or the negative current resulting from the back electromotive force at power OFF. IC breakdown may cause injury, smoke or ignition.
Use a stable power supply with ICs with built-in protection functions. If the power supply is unstable, the protection function may not operate, causing IC breakdown. IC breakdown may cause injury, smoke or ignition.
- [4] Do not insert devices in the wrong orientation or incorrectly.
Make sure that the positive and negative terminals of power supplies are connected properly.
Otherwise, the current or power consumption may exceed the absolute maximum rating, and exceeding the rating(s) may cause the device breakdown, damage or deterioration, and may result injury by explosion or combustion.
In addition, do not use any device that is applied the current with inserting in the wrong orientation or incorrectly even just one time.

- [5] Carefully select external components (such as inputs and negative feedback capacitors) and load components (such as speakers), for example, power amp and regulator.
If there is a large amount of leakage current such as input or negative feedback condenser, the IC output DC voltage will increase. If this output voltage is connected to a speaker with low input withstand voltage, overcurrent or IC failure can cause smoke or ignition. (The over current can cause smoke or ignition from the IC itself.) In particular, please pay attention when using a Bridge Tied Load (BTL) connection type IC that inputs output DC voltage to a speaker directly.

Points to remember on handling of ICs

(1) Over current Protection Circuit

Over current protection circuits (referred to as current limiter circuits) do not necessarily protect ICs under all circumstances. If the Over current protection circuits operate against the over current, clear the over current status immediately.

Depending on the method of use and usage conditions, such as exceeding absolute maximum ratings can cause the over current protection circuit to not operate properly or IC breakdown before operation. In addition, depending on the method of use and usage conditions, if over current continues to flow for a long time after operation, the IC may generate heat resulting in breakdown.

(2) Thermal Shutdown Circuit

Thermal shutdown circuits do not necessarily protect ICs under all circumstances. If the thermal shutdown circuits operate against the over temperature, clear the heat generation status immediately.

Depending on the method of use and usage conditions, such as exceeding absolute maximum ratings can cause the thermal shutdown circuit to not operate properly or IC breakdown before operation.

(3) Heat Radiation Design

In using an IC with large current flow such as power amp, regulator or driver, please design the device so that heat is appropriately radiated, not to exceed the specified junction temperature (T_j) at any time and condition. These ICs generate heat even during normal use. An inadequate IC heat radiation design can lead to decrease in IC life, deterioration of IC characteristics or IC breakdown. In addition, please design the device taking into consideration the effect of IC heat radiation with peripheral components.

(4) Back-EMF

When a motor rotates in the reverse direction, stops or slows down abruptly, a current flow back to the motor's power supply due to the effect of back-EMF. If the current sink capability of the power supply is small, the device's motor power supply and output pins might be exposed to conditions beyond absolute maximum ratings. To avoid this problem, take the effect of back-EMF into consideration in system design.

RESTRICTIONS ON PRODUCT USE

- Toshiba Corporation, and its subsidiaries and affiliates (collectively "TOSHIBA"), reserve the right to make changes to the information in this document, and related hardware, software and systems (collectively "Product") without notice.
- This document and any information herein may not be reproduced without prior written permission from TOSHIBA. Even with TOSHIBA's written permission, reproduction is permissible only if reproduction is without alteration/omission.
- Though TOSHIBA works continually to improve Product's quality and reliability, Product can malfunction or fail. Customers are responsible for complying with safety standards and for providing adequate designs and safeguards for their hardware, software and systems which minimize risk and avoid situations in which a malfunction or failure of Product could cause loss of human life, bodily injury or damage to property, including data loss or corruption. Before customers use the Product, create designs including the Product, or incorporate the Product into their own applications, customers must also refer to and comply with (a) the latest versions of all relevant TOSHIBA information, including without limitation, this document, the specifications, the data sheets and application notes for Product and the precautions and conditions set forth in the "TOSHIBA Semiconductor Reliability Handbook" and (b) the instructions for the application with which the Product will be used with or for. Customers are solely responsible for all aspects of their own product design or applications, including but not limited to (a) determining the appropriateness of the use of this Product in such design or applications; (b) evaluating and determining the applicability of any information contained in this document, or in charts, diagrams, programs, algorithms, sample application circuits, or any other referenced documents; and (c) validating all operating parameters for such designs and applications. **TOSHIBA ASSUMES NO LIABILITY FOR CUSTOMERS' PRODUCT DESIGN OR APPLICATIONS.**
- **PRODUCT IS NEITHER INTENDED NOR WARRANTED FOR USE IN EQUIPMENTS OR SYSTEMS THAT REQUIRE EXTRAORDINARILY HIGH LEVELS OF QUALITY AND/OR RELIABILITY, AND/OR A MALFUNCTION OR FAILURE OF WHICH MAY CAUSE LOSS OF HUMAN LIFE, BODILY INJURY, SERIOUS PROPERTY DAMAGE AND/OR SERIOUS PUBLIC IMPACT ("UNINTENDED USE").** Except for specific applications as expressly stated in this document, Unintended Use includes, without limitation, equipment used in nuclear facilities, equipment used in the aerospace industry, medical equipment, equipment used for automobiles, trains, ships and other transportation, traffic signaling equipment, equipment used to control combustions or explosions, safety devices, elevators and escalators, devices related to electric power, and equipment used in finance-related fields. **IF YOU USE PRODUCT FOR UNINTENDED USE, TOSHIBA ASSUMES NO LIABILITY FOR PRODUCT.** For details, please contact your TOSHIBA sales representative.
- Do not disassemble, analyze, reverse-engineer, alter, modify, translate or copy Product, whether in whole or in part.
- Product shall not be used for or incorporated into any products or systems whose manufacture, use, or sale is prohibited under any applicable laws or regulations.
- The information contained herein is presented only as guidance for Product use. No responsibility is assumed by TOSHIBA for any infringement of patents or any other intellectual property rights of third parties that may result from the use of Product. No license to any intellectual property right is granted by this document, whether express or implied, by estoppel or otherwise.
- **ABSENT A WRITTEN SIGNED AGREEMENT, EXCEPT AS PROVIDED IN THE RELEVANT TERMS AND CONDITIONS OF SALE FOR PRODUCT, AND TO THE MAXIMUM EXTENT ALLOWABLE BY LAW, TOSHIBA (1) ASSUMES NO LIABILITY WHATSOEVER, INCLUDING WITHOUT LIMITATION, INDIRECT, CONSEQUENTIAL, SPECIAL, OR INCIDENTAL DAMAGES OR LOSS, INCLUDING WITHOUT LIMITATION, LOSS OF PROFITS, LOSS OF OPPORTUNITIES, BUSINESS INTERRUPTION AND LOSS OF DATA, AND (2) DISCLAIMS ANY AND ALL EXPRESS OR IMPLIED WARRANTIES AND CONDITIONS RELATED TO SALE, USE OF PRODUCT, OR INFORMATION, INCLUDING WARRANTIES OR CONDITIONS OF MERCHANTABILITY, FITNESS FOR A PARTICULAR PURPOSE, ACCURACY OF INFORMATION, OR NONINFRINGEMENT.**
- Do not use or otherwise make available Product or related software or technology for any military purposes, including without limitation, for the design, development, use, stockpiling or manufacturing of nuclear, chemical, or biological weapons or missile technology products (mass destruction weapons). Product and related software and technology may be controlled under the applicable export laws and regulations including, without limitation, the Japanese Foreign Exchange and Foreign Trade Law and the U.S. Export Administration Regulations. Export and re-export of Product or related software or technology are strictly prohibited except in compliance with all applicable export laws and regulations.
- Please contact your TOSHIBA sales representative for details as to environmental matters such as the RoHS compatibility of Product. Please use Product in compliance with all applicable laws and regulations that regulate the inclusion or use of controlled substances, including without limitation, the EU RoHS Directive. **TOSHIBA ASSUMES NO LIABILITY FOR DAMAGES OR LOSSES OCCURRING AS A RESULT OF NONCOMPLIANCE WITH APPLICABLE LAWS AND REGULATIONS.**