

System Demonstration Platform Facilitates Quick Prototyping and Evaluation

By Rosemary Ryan

System design can be a complex problem with many different elements to comprehend, but the ability to prototype and quickly demonstrate subsections of the solution can simplify the process and, more importantly, reduce the risks faced by designers. With the Analog Devices (ADI) [System Demonstration Platform \(SDP\)](#), system designers can reuse central elements, allowing subsections of their designs to be evaluated and demonstrated prior to the final system implementation. Component and reference circuit evaluation boards from across ADI's portfolio are now available on the SDP, with more becoming available all the time. The familiarity gained from prior use of the platform makes it easy for users to evaluate new categories of components in an environment they already know and understand. The SDP connects to FPGA evaluation and prototyping platforms, allowing easy creation and demonstration of customized FPGA embedded designs that communicate with ADI components. Users can build customized evaluation and prototyping systems quickly, and the ability to reuse various platform elements makes demonstrating a wide variety of hardware and software concepts easy and affordable.

Platform Overview

As shown in Figure 1, the System Demonstration Platform comprises a series of *controller boards*, *interposer boards*, and *daughter boards* that implement an easy to use evaluation system for ADI components and reference circuits that use them. Controller boards connect to a PC through a USB 2.0 link and to SDP-compatible daughter boards via on-board connectors. Daughter boards include dedicated component evaluation boards and [Circuits from the Lab™](#) reference circuits. Interposer boards connect controller boards to daughter boards, or adapt SDP daughter boards to third-party tools. A standard, small-footprint, 120-pin connector with defined pinout is common to all boards in the platform, allowing a customized system to be built and altered easily. Controller boards have a 120-pin connector header; daughter boards have a receptacle connector; and interposer boards have a header, a receptacle, or both, depending on their functionality.

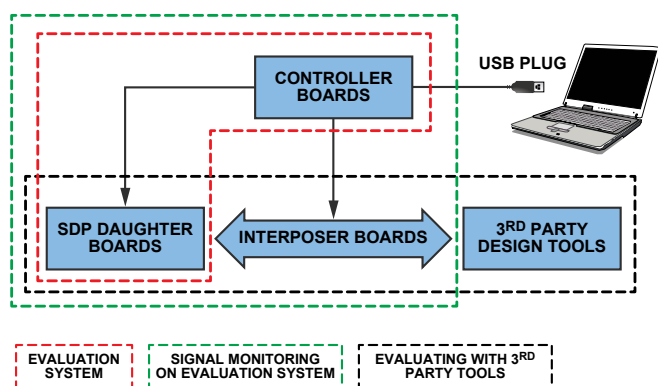

Figure 1. System Demonstration Platform overview.

Controller Boards

The two types of controller boards, the SDP-B and the SDP-S, are shown in Figure 2. Both require a USB 2.0 link for control and data transfer between the system and the PC-based user interface.

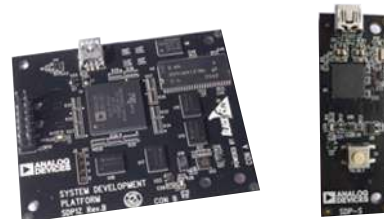

Figure 2. Controller boards: a) SDP-B. b) SDP-S.

The SDP-B, with an [ADSP-BF527](#) Blackfin® processor at its core, is a small-form-factor board that uses a USB mini-B connector for PC connectivity, as shown in Figure 3. The Blackfin processor functions as the USB controller, and also provides a range of peripheral interfaces to the daughter board. Available via two identical 120-pin connectors, these interfaces include SPI, SPORT, I²C, GPIOs, timers, PPI, and asynchronous parallel. The SDP-B controller can be used with any daughter board designed for the SDP. The two 120-pin connectors facilitate simultaneous connection of two daughter boards to a single controller board.

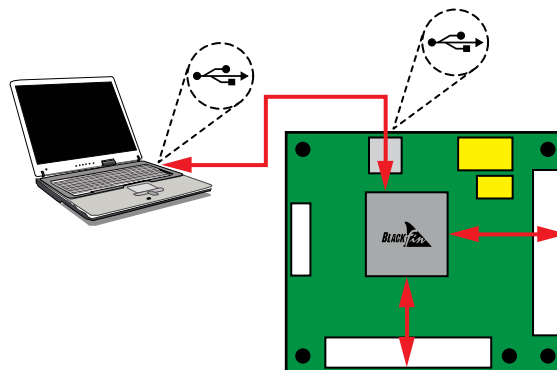

Figure 3. SDP-B controller functional overview.

The SDP-S, a small, low-cost, serial-only controller board provides a reduced set of peripheral interfaces as compared to the SDP-B. With a USB-to-serial engine at its core, the SDP-S has a single 120-pin connector that is pin-compatible with the connectors on the SDP-B. Its subset of peripheral interfaces includes SPI, I²C, and GPIOs. All boards designed to work with the SDP-S will work with the SDP-B, as the SDP-B provides a superset of the SDP-S capabilities. Table 1 compares the peripheral interfaces available with SDP-B and SDP-S boards.

Table 1. Controller Boards

Peripheral Interface	SDP-B	SDP-S
SPI	•	•
SPORT	•	
GPIO	•	•
I ² C	•	•
Asynchronous Parallel	•	
PPI	•	
Timers	•	

Daughter Evaluation Boards

An increasing variety of data-converter, mixed-signal, and RF component evaluation boards are being designed to work with the System Demonstration Platform, as shown in Figure 4. With a single controller board, customers need only purchase a daughter board for the specific component or reference circuit that they want to evaluate during their selection process. Circuits from the Lab reference circuits are subsystem-level building blocks that combine multiple ADI components to solve common design challenges. Engineered, tested, and documented for quick and easy system integration, connecting these boards to the SDP allows users to prototype complete reference circuits as easily as individual components. A full list of compatible daughter boards can be found at www.analog.com/sdp. Daughter boards may be externally powered if necessary, and each includes software for communicating with the PC via the controller, as shown in Figure 5.

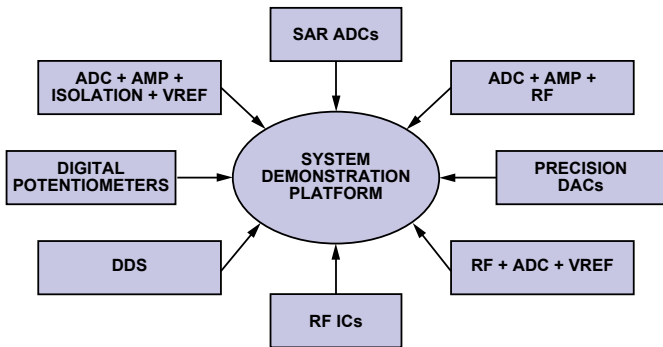

Figure 4. Universal evaluation platform for system-critical technologies.

Interposer Boards

The SDP includes a variety of interposer boards that route signals between two elements of the platform or connect elements of the platform to third-party evaluation systems. The SDP breakout board sits between a controller board and a daughter board. One end has a 120-pin receptacle connector allowing connection to a controller board; the other end has a 120-pin header connector allowing connection to a daughter board. The signals from the receptacle are routed directly to the header. Each signal line has a through-hole probe point allowing it to be individually monitored. In this way, each signal on the 120-pin connector can be easily accessed.

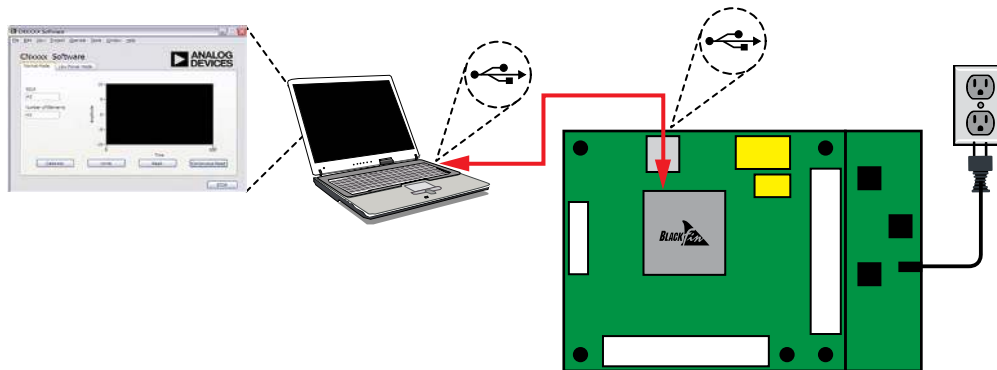

Figure 5. Evaluation setup.

Easy Integration with FPGA Design

The BeMicro SDK-SDP Interposer connects SDP daughter boards to the **BeMicro SDK** (solution development kit) for the creation of embedded FPGA system prototypes. The BeMicro SDK was developed by Arrow in association with Altera. Its 120-pin connector header routes signals from component evaluation boards or Circuits from the Lab reference circuit boards to a Samtec edge connector that attaches to the BeMicro SDK. Powered by a NIOS® II processor and paired with an Eclipse-based integrated-design environment, the BeMicro SDK allows users to customize embedded processor designs easily and prototype solutions with Altera's Cyclone® 4 FPGA and a range of ADI evaluation boards. Provided by Arrow in association with Altera, the BeMicro SDK utilizes the familiar USB stick form factor. The BeMicro SDK and BeMicro SDK-SDP Interposer can be purchased directly from Arrow. Figure 6 shows the BeMicro SDK, BeMicro SDK-SDP Interposer, and an ADI component evaluation board.

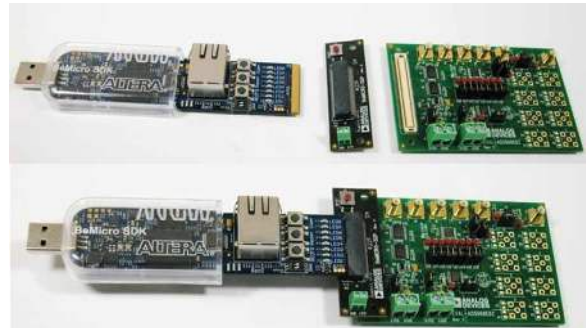

Figure 6. BeMicro SDK, interposer, and SDP controller.

Purchasing Platform Elements

More information on the controller boards, interposer boards, and daughter boards can be found at www.analog.com/sdp and www.arrow.com/interposer. Table 2 shows platform board pricing.

Table 2. Platform Board Pricing

Board	Price
SDP-B	\$99
SDP-S	\$49
SDP Breakout Board	\$49.95
BeMicro-SDP Interposer	\$30
Daughter Boards	From \$50

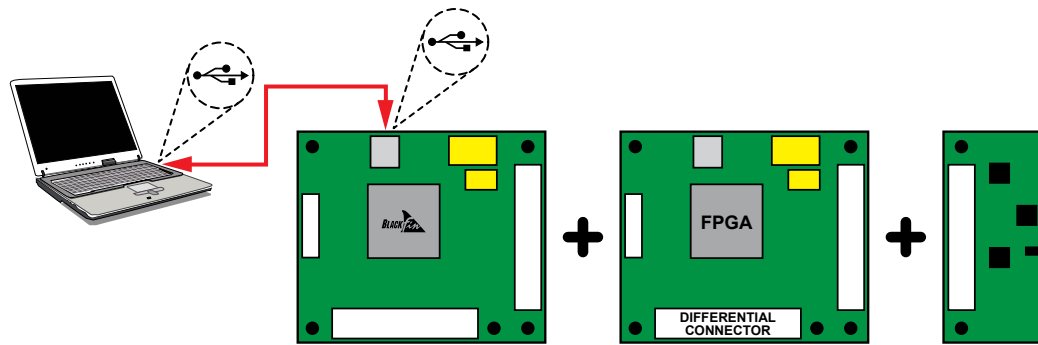

Figure 7. FPGA system function module.

Future Modules

With the goal of simplifying the system design process by providing easy-to-use demonstration and evaluation elements that solve a growing set of problems, the System Demonstration Platform will continue to evolve and expand. In September 2011, System Function Modules will be added to the platform to provide additional functionality to the existing platform. The first module will be an FPGA module. The SDP-FPGA module will sit between a controller board and a daughter board, increasing the flexibility of a demonstration or prototype system. The SDP-FPGA module will connect to the 120-pin connector on the controller board and will have a 120-pin header connector for connection to daughter boards. The SDP-FPGA board will also have a differential connector, allowing components with differential signaling interfaces to be included on the SDP platform.

Conclusion

The System Demonstration Platform provides system designers with a level of flexibility previously unavailable from a single ADI platform. As the platform continues to grow and develop,

its effectiveness as a reusable, customizable system demonstrator and prototype builder increases. The diversity of available daughter boards, including both component evaluation boards and Circuits from the Lab reference circuits, ensures that the System Demonstration Platform can provide a one-stop solution to a designer's evaluation and demonstration needs. Visit www.analog.com/sdp to keep up to date with all the latest news and releases on the SDP.

Author

Rosemary Ryan [rosemary.ryan@analog.com]

is an applications engineer with the Precision System Applications team. She graduated from the University of Limerick with a BEng in computer engineering in 2005 and joined ADI in Limerick in 2006. In 2010 she graduated from Waterford Institute of Technology with an MEng in Electronic Engineering. She currently works as part of the team responsible for the development of the System Demonstration Platform (SDP).

