

ALMD-CY3G-YZx02

High Brightness SMT Round White LED Lamps

Overview

The new Broadcom® ALMD-CY3G series is essentially like a conventional high-brightness through-hole LED in the form of a surface mount device. It can be assembled using common SMT assembly processes and is compatible with industrial soldering processes.

The LEDs are made with an advanced optical grade epoxy for superior performance in outdoor sign applications. For easy pick-and-place assembly, the LEDs are packed in a tape and reel format. Every reel is shipped in single intensity and color bin to ensure uniformity.

Features

- High brightness InGaN
- Typical viewing angle: 33°
- Supports EN12966-1 white color class C2
- JEDEC MSL3
- Compatible with industrial reflow soldering process

Applications

- Variable message signs
- Highway signs

CAUTION!

This LED is ESD sensitive. Please observe appropriate precautions during handling and processing. Refer to application note AN-1142 for additional details.

The LED must be kept in a moisture barrier bag with < 5% relative humidity (RH) when not in use because prolonged exposure to the environment might cause the leads to tarnish or rust, which might cause difficulties in soldering.

Figure 1: Package Drawing

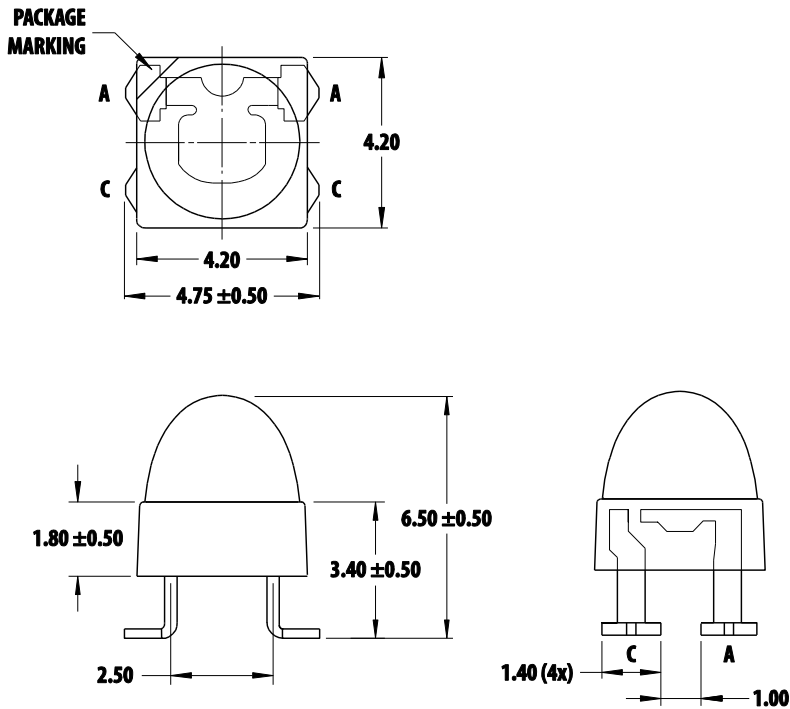

NOTE:

1. All dimensions in millimeters (mm).
2. Tolerance is ± 0.20 mm unless otherwise specified.
3. Mildsteel leadframe.

Device Selection Guide ($T_J = 25^\circ\text{C}$, $I_F = 20$ mA)

Part Number	Chromaticity Coordinate	Luminous Intensity, I_V (mcd) ^{a, b}		Color Bin
	Typ.	Min.	Max.	
ALMD-CY3G-YZ002	0.32, 0.33	9300	16000	E1, E2, E3, E4
ALMD-CY3G-YZF02	0.32, 0.33	9300	16000	E1, E2, E3

a. The luminous intensity, I_V is measured at the mechanical axis of the LED package, and it is tested with mono pulse current. The actual peak of the spatial radiation pattern may not align with the mechanical axis.

b. Tolerance is $\pm 15\%$.

Absolute Maximum Ratings

Parameters	White	Units
DC Forward Current ^a	30	mA
Peak Forward Current ^b	100	mA
Power Dissipation	105	mW
Reverse Voltage	Not recommended for reverse bias	V
LED Junction Temperature	100	°C
Operating Temperature Range	-40 to +85	°C
Storage Temperature Range	-40 to +100	°C

a. Derate linearly as shown in [Figure 12](#).

b. Duty factor = 10%, frequency = 1 kHz.

Optical and Electrical Characteristics (T_J = 25°C, I_F = 20 mA)

Parameters	Min.	Typ.	Max.	Units
Viewing Angle, 2θ _{1/2} ^a	—	33	—	°
Forward Voltage, V _F ^b	2.70	2.90	3.50	V
Reverse Voltage, V _R at I _R = 10 μA ^c	5	—	—	V
Chromaticity Coordinate	—	0.32, 0.33	—	—
Thermal Resistance, R _{θJ-P} ^d	—	350	—	°C/W

a. θ_{1/2} is the off-axis angle where the luminous intensity is 1/2 the peak intensity. The actual peak of the spatial radiation pattern may not align with the mechanical axis.

b. Tolerance is ±0.05V.

c. Indicates product final test condition only. Long term reverse bias is not recommended.

d. Thermal resistance from LED junction to pin.

Part Numbering System

A L M D - C Y

x ₁	x ₂
----------------	----------------

 -

x ₃	x ₄	x ₅	x ₆	x ₇
----------------	----------------	----------------	----------------	----------------

Code	Description	Option	
x ₁	Viewing angle	3	33°
x ₂	Lens appearance	G	Diffused
x ₃	Minimum intensity bin	Y	9300–12,000
x ₄	Maximum intensity bin	Z	12,000–16,000
x ₅	Color bin	0	Bin E1, E2, E3, E4
		F	Bin E1, E2, E3
x ₆ x ₇	Packaging option	02	Tested at 20 mA

Part Number Example

ALMD-CY3G-YZ002

x₁ : 3 – 33°
 x₂ : G – Diffused
 x₃ : Y – Minimum intensity bin Y
 x₄ : Z – Maximum intensity bin Z
 x₅ : 0 – Color bin E1, E2, E3, E4
 x₆ x₇ : 02 – Tested at 20 mA

Bin Information

Luminous Intensity Bin Limits (CAT)

Bin ID	Luminous Intensity (mcd)	
	Min.	Max.
Y	9300	12,000
Z	12,000	16,000

Tolerance = $\pm 15\%$

Example of bin information on reel and packaging label:

CAT : Y – Intensity bin Y
 BIN : E2 – Color bin E2

Color Bin Limits (BIN)

Bin ID	Chromaticity Coordinates	
	x	y
E1	0.300	0.320
	0.310	0.336
	0.310	0.290
	0.300	0.276
E2	0.310	0.336
	0.320	0.350
	0.320	0.305
	0.310	0.290
E3	0.320	0.350
	0.330	0.360
	0.330	0.320
	0.320	0.305
E4	0.330	0.360
	0.340	0.368
	0.340	0.334
	0.330	0.320

Tolerance = ± 0.01

Figure 2: Chromaticity Diagram

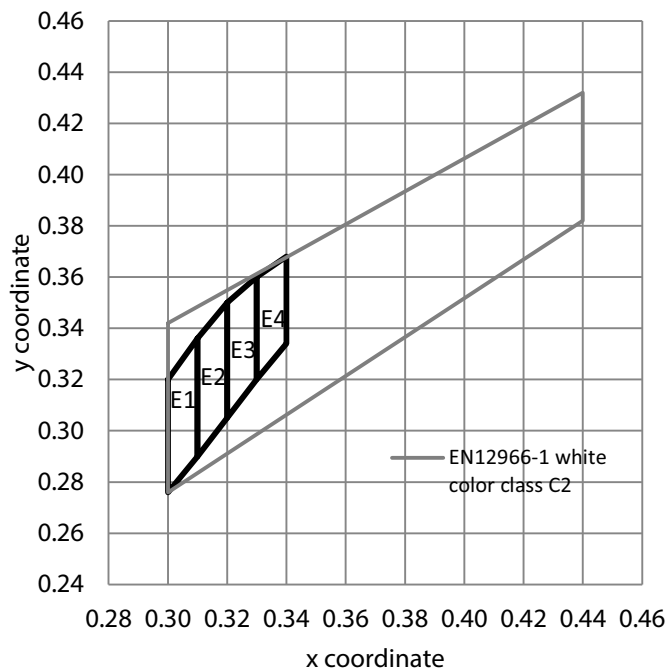

Figure 3: Spectral Power Distribution

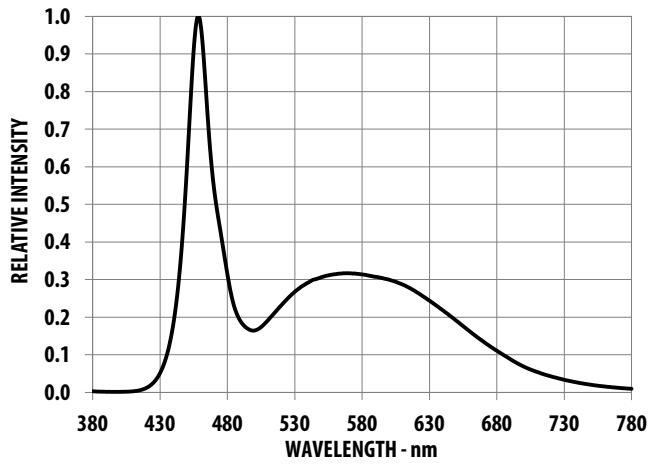

Figure 4: Forward Current vs. Forward Voltage

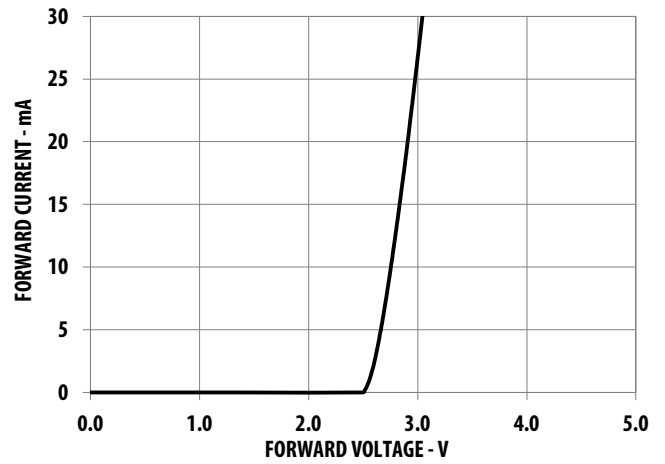

Figure 5: Relative Luminous Intensity vs. Mono Pulse Current

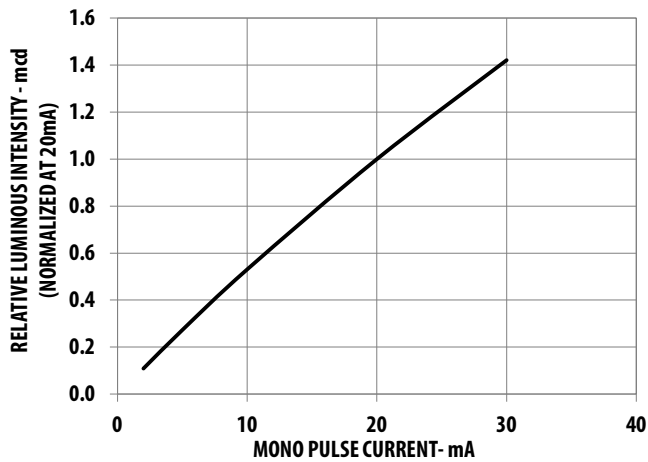

Figure 6: Chromaticity Coordinate Shift vs. Mono Pulse Current

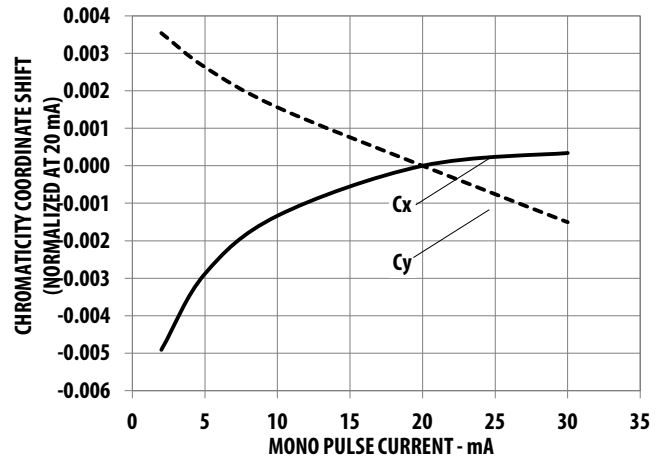

Figure 7: Relative Light Output vs. Junction Temperature

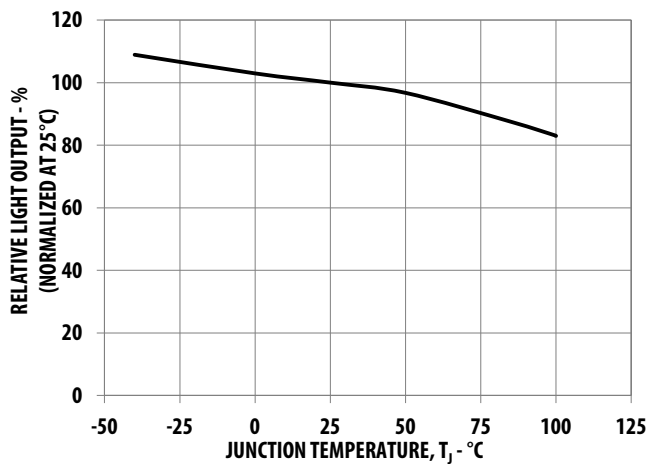

Figure 8: Forward Voltage Shift vs. Junction Temperature

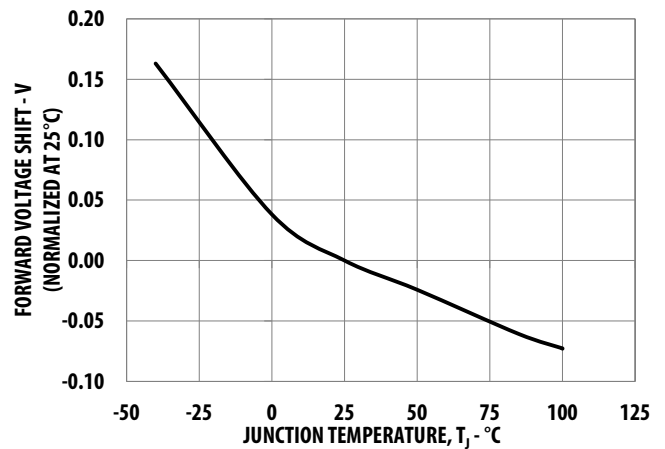

Figure 9: Chromaticity Coordinate Shift vs. Junction Temperature

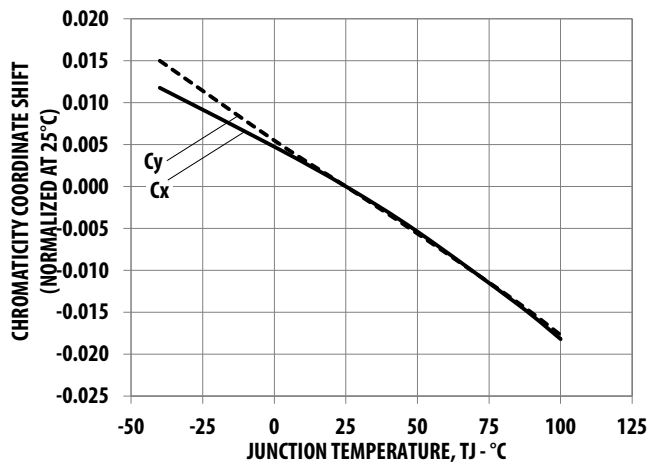

Figure 10: Radiation Pattern

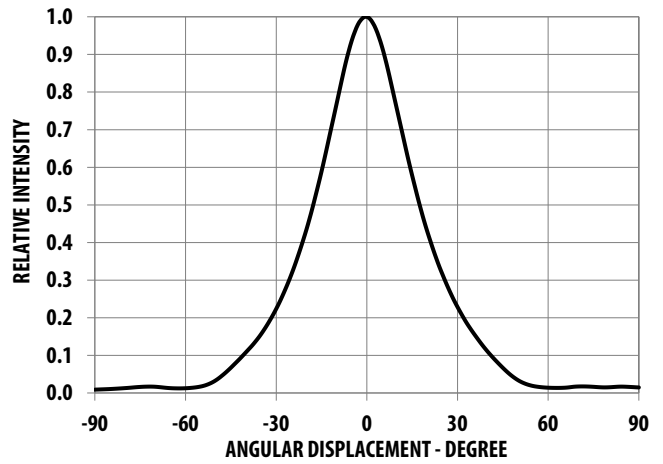

Figure 11: Component Axis for Radiation Pattern

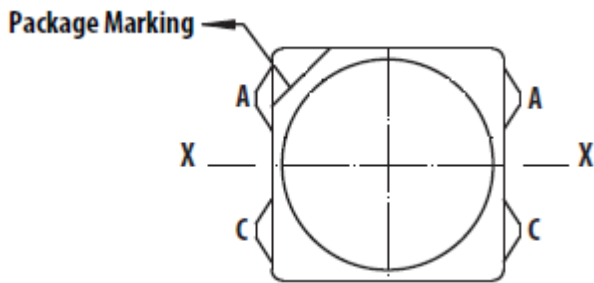

Figure 12: Maximum Forward Current vs. Ambient Temperature. Derated based on $T_{JMAX} = 100^\circ\text{C}$

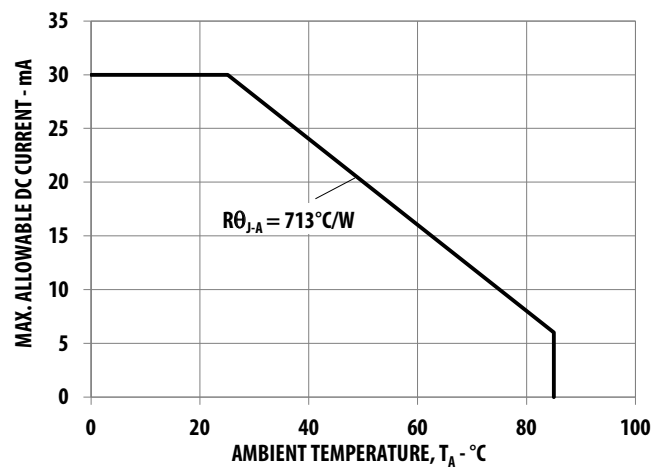
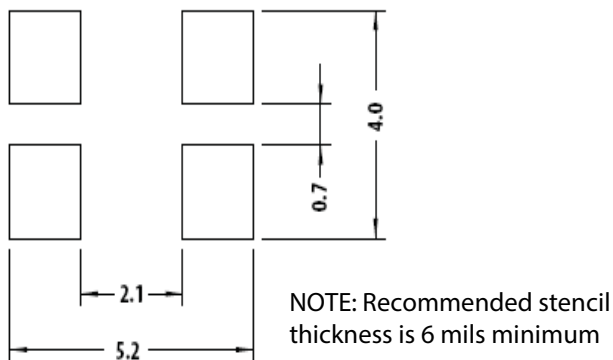
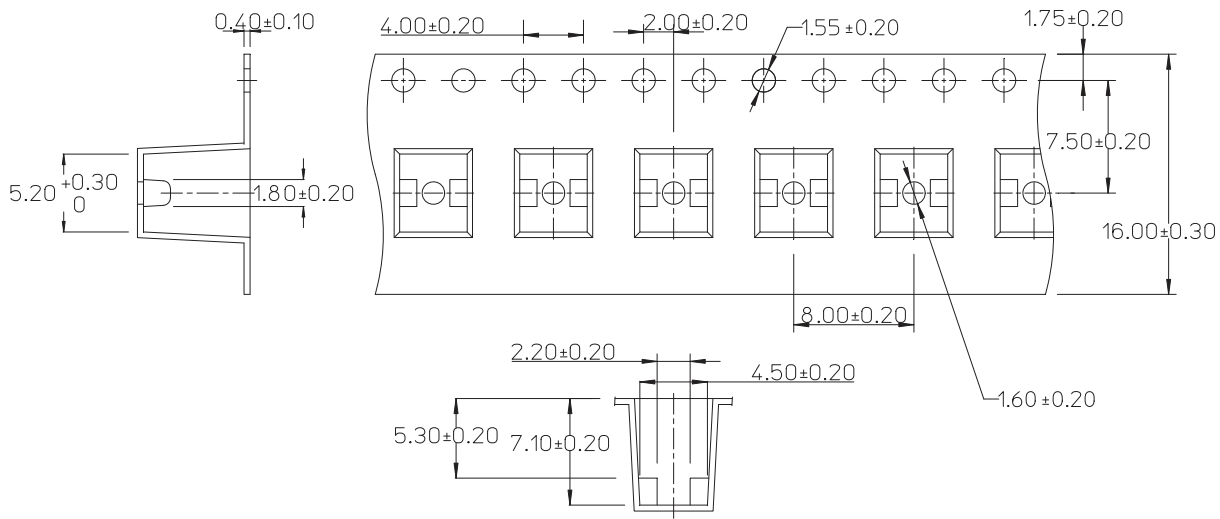

Figure 13: Recommended Soldering Land Pattern



NOTE: All dimensions are in millimeters (mm).

Figure 14: Carrier Tape Dimensions



NOTE: All dimensions are in millimeters (mm).

Figure 15: Reel Dimensions

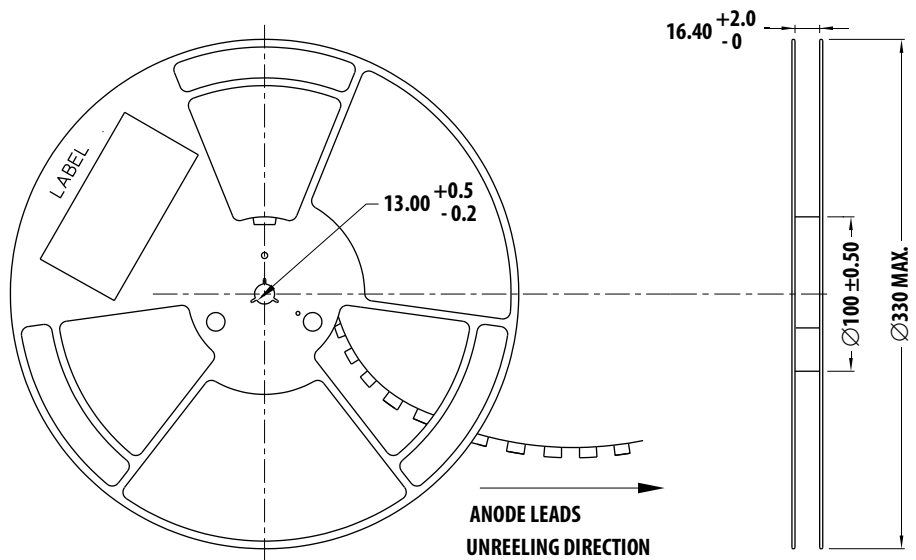

NOTE: All dimensions are in millimeters (mm).

Precautionary Notes

Soldering

- Do not perform reflow soldering more than twice. Observe necessary precautions of handling moisture-sensitive devices as stated in the following section.
- Do not apply any pressure or force on the LED during reflow and after reflow when the LED is still hot.
- Use reflow soldering to solder the LED. Use hand soldering only for rework if unavoidable, but it must be strictly controlled to following conditions:
 - Soldering iron tip temperature = 315°C maximum
 - Soldering duration = 3s maximum
 - Number of cycles = 1 only
 - Power of soldering iron = 50W maximum
- Do not touch the LED package body with the soldering iron except for the soldering terminals, because it may cause damage to the LED.
- Confirm beforehand whether the functionality and performance of the LED is affected by soldering with hand soldering.

Figure 16: Recommended Lead-Free Reflow Soldering Profile

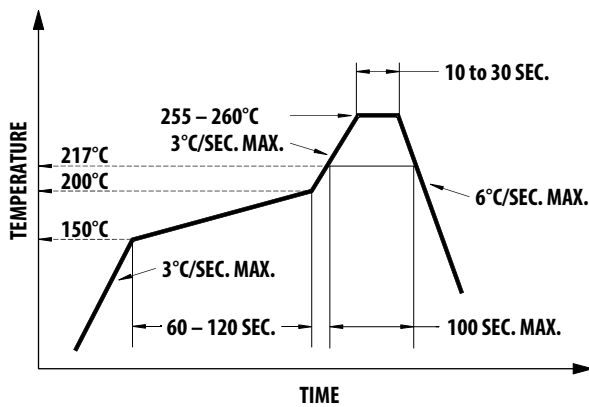
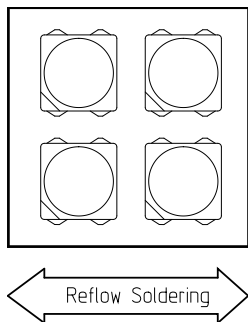

Figure 17: Recommended Board Reflow Direction



Handling Precautions

For automated pick-and-place, Broadcom has tested the following nozzle size to work well with this LED. However, due to the possibility of variations in other parameters, such as pick-and-place machine maker/model, and other settings of the machine, verify that the selected nozzle will not cause damage to the LED.

Figure 18: Recommended Nozzle Dimension

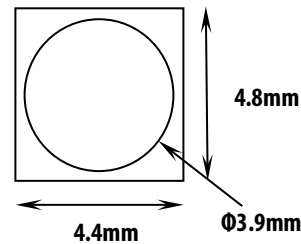
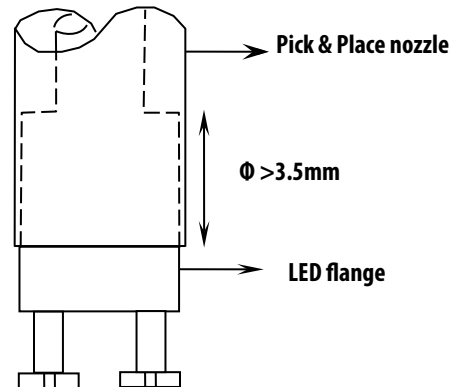

NOTE:

1. The nozzle tip must touch the LED flange during pick and place.
2. The outer dimensions of the nozzle tip must be able to fit into the carrier tape pocket until it touches the LED flange.
3. All dimensions are in millimeters (mm).

Handling of Moisture-Sensitive Devices

This product has a Moisture Sensitive Level 3 rating per JEDEC J-STD-020. Refer to Broadcom Application Note AN5305, *Handling of Moisture Sensitive Surface Mount Devices* for additional details and a review of proper handling procedures.

- Before use:
 - An unopened moisture barrier bag (MBB) can be stored at < 40°C/90% RH for 12 months. If the actual shelf life has exceeded 12 months and the humidity indicator card (HIC) indicates that baking is not required, it is safe to reflow the LEDs per the original MSL rating.
 - Do not open the MBB prior to assembly (for example, for IQC). If unavoidable, the MBB must be properly resealed with fresh desiccant and HIC. The exposed duration must be taken in as floor life.
- Control after opening the MBB:
 - Read the HIC immediately upon opening of MBB.
 - Keep the LEDs at < 30°C/60% RH at all times, and complete all high temperature-related processes, including soldering, curing, or rework within 168 hours.
- Control for unfinished reel:

Store unused LEDs in a sealed MBB with desiccant or a desiccator at < 5% RH.
- Control of assembled boards:

If the PCB soldered with the LEDs is to be subjected to other high-temperature processes, store the PCB in a sealed MBB with desiccant or desiccator at < 5% RH to ensure that all LEDs have not exceeded their floor life of 168 hours.
- Baking is required if:
 - The HIC indicator indicates a change in color for 10% and 5%, as stated on the HIC.
 - The LEDs are exposed to conditions of > 30°C/60% RH at any time.
 - The LED's floor life exceeded 168 hours.

The recommended baking condition is: 60°C ± 5°C for 20 hours.

Baking can only be done once.

- Storage:

The soldering terminals of these Broadcom LEDs are silver plated. If the LEDs are exposed in ambient environments for too long, the silver plating might be oxidized, thus affecting its solderability performance. As such, keep unused LEDs in a sealed MBB with desiccant or in a desiccator at < 5% RH.

Application Precautions

- The drive current of the LED must not exceed the maximum allowable limit across temperature as stated in the data sheet. Constant current driving is recommended to ensure consistent performance.
- Circuit design must cater to the whole range of forward voltage (V_F) of the LEDs to ensure the intended drive current can always be achieved.
- The LED exhibits slightly different characteristics at different drive currents, which may result in a larger variation of performance (meaning: intensity, wavelength, and forward voltage). Set the application current as close as possible to the test current to minimize these variations.
- The LED is not intended for reverse bias. Use other appropriate components for such purposes. When driving the LED in matrix form, ensure that the reverse bias voltage does not exceed the allowable limit of the LED.
- White LEDs must not be exposed to acidic environments and must not be used in the vicinity of any compound that may have acidic outgas, such as, but not limited to, acrylate adhesive. These environments have an adverse effect on LED performance.
- As actual application might not be exactly similar to the test conditions, do verify that the LED will not be damaged by prolonged exposure in the intended environment.
- Avoid rapid changes in ambient temperature, especially in high-humidity environments, because they cause condensation on the LED.
- If the LED is intended to be used in harsh or outdoor environments, protect the LED against damages caused by rain water, water, dust, oil, corrosive gases, external mechanical stresses, and so on.

Eye Safety Precautions

LEDs may pose optical hazards when in operation. Do not look directly at operating LEDs because it might be harmful to the eyes. For safety reasons, use appropriate shielding or personal protective equipment.

Disclaimer

Broadcom's products and software are not specifically designed, manufactured, or authorized for sale as parts, components, or assemblies for the planning, construction, maintenance, or direct operation of a nuclear facility or for use in medical devices or applications. The customer is solely responsible, and waives all rights to make claims against Broadcom or its suppliers, for all loss, damage, expense, or liability in connection with such use.

Broadcom, the pulse logo, Connecting everything, Avago Technologies, Avago, and the A logo are among the trademarks of Broadcom and/or its affiliates in the United States, certain other countries and/or the EU.

Copyright © 2017 by Broadcom. All Rights Reserved.

The term "Broadcom" refers to Broadcom Limited and/or its subsidiaries. For more information, please visit www.broadcom.com.

Broadcom reserves the right to make changes without further notice to any products or data herein to improve reliability, function, or design. Information furnished by Broadcom is believed to be accurate and reliable. However, Broadcom does not assume any liability arising out of the application or use of this information, nor the application or use of any product or circuit described herein, neither does it convey any license under its patent rights nor the rights of others.

