

4-Pin LED Lamp (7.6 mm)

OVFSxxC8



Features:

- Packaged in tubes
- Compatible with automatic placement equipment
- Compatible with infrared and vapor phase reflow solder process
- Mono-colors
- Pb-free



Description:

The OVFSxxC8 series is designed with higher forward voltage to maximize brightness and incorporates a low-profile lens to enhance efficient light distribution. Response time is fast and it consumes less power resulting in low current requirements from circuit power supply. Tubular arrays replace neon in outdoor and indoor signs. This square package allows high-density arrays to form light engines.

Applications:

- Automotive: Rear stop/turn signal lamps/truck marker lamps
- Mood-setting decoration and landscape lighting
- Special decorative interior/exterior lighting
- Special effects stage lighting
- Illumination for signs and channel letters
- Traffic signals, pedestrian and walkway signs

Part Number	DIM A	Beam Angle	Material	Emitted Color	Flux Typ. mlm	Lens Color
OVFSAAC8 <i>Obsolete per EOL1027</i>	[1.50] .059	100°	AllInGaP	Amber	8000	Clear
OVFSB7C8 <i>Obsolete per EOL1038</i>	[1.29] .051	70°	InGaN	Blue	2500	Clear
OVFSG7C8 <i>Obsolete per EOL1026</i>	[1.29] .051	70°	InGaN	Green	8500	Clear
OVFSRAC8	[1.50] .059	100°	AllInGaP	Red	8000	Clear
OVFSW6C8	[1.90] .075	60°	InGaN	White	7000	Clear

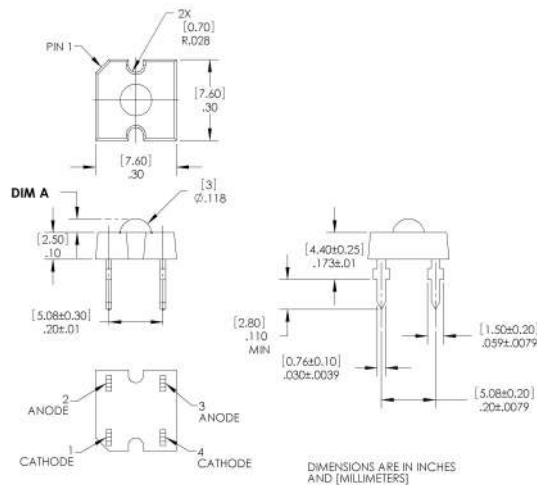

**DO NOT LOOK DIRECTLY AT LED
WITH UNSHIELDED EYES OR
DAMAGE TO RETINA MAY
OCCUR.**

General Note

TT Electronics reserves the right to make changes in product specification without notice or liability. All information is subject to TT Electronics' own data and is considered accurate at time of going to print.

TT Electronics | OPTEK Technology
2900 E. Plano Pkwy, Plano, TX 75074 | Ph: +1 972 323 2200
www.ttelectronics.com | sensors@ttelectronics.com

4-Pin LED Lamp (7.6 mm)

OVFSxxC8



Electrical Specifications

Absolute Maximum Ratings $T_A = 25^\circ \text{C}$ unless otherwise noted

Storage Temperature Range	Blue, Green, Red, Amber, White	-40 ~ +100 °C
Operating Temperature Range	Blue, Green, Red, Amber	-40 ~ +100 °C
	White	-40 ~ +95 °C
Reverse Voltage		5 V
Continuous Forward Current	Blue, Green, White	35 mA
	Red, Amber	70 mA
Peak Forward Current (10% Duty Cycle, 1 kHz)	Blue, Green, White	100 mA
	Red, Amber	200 mA
Power Dissipation	Blue, Green, White	154 mW
	Red, Amber	210 mW
Lead Soldering Temperature (3mm from the base of the epoxy bulb)		260° C / 3 sec max
Electrostatic Discharge Classification (JEDE-JESD22-A114F)		Class 2

Optical and Electrical Characteristics ($T_A = 25^\circ \text{C}$)

SYMBOL	PARAMETER	COLOR	MIN	TYP	MAX	UNITS	CONDITIONS
Φ_v	Luminous Flux	Blue	1650	2500	----	mlm	$I_F = 30 \text{ mA}$
		Green	5500	8500	----		
		White	3850	7000	----		
		Red	5500	8000	----		$I_F = 70 \text{ mA}$
		Amber	6600	8000	----		
V_F	Forward Voltage	Blue & Green	----	3.6	4.4	V	$I_F = 30 \text{ mA}$
		White	----	3.6	4.4		$I_F = 70 \text{ mA}$
		Red, Amber	----	2.5	3.0		
I_R	Reverse Current	Blue & Green	----	----	100	μA	$V_R = 5 \text{ V}$
		White					
		Red, Amber					
λ_D	Dominant Wavelength	Blue	460	470	475	nm	$I_F = 30 \text{ mA}$
		Green	515	527	535		$I_F = 70 \text{ mA}$
		Red	620	628	637		
		Amber	584	591	599		
x	Chromaticity Coordinates White			0.2895			$I_F = 30 \text{ mA}$
y				0.2905			
$2\Theta_{\frac{1}{2}H-H}$	50% Power Angle	Blue & Green	----	70	----	deg	$I_F = 30 \text{ mA}$
		White	----	60	----		
		Red, Amber	----	100	----		$I_F = 70 \text{ mA}$

General Note

TT Electronics reserves the right to make changes in product specification without notice or liability. All information is subject to TT Electronics' own data and is considered accurate at time of going to print.

TT Electronics | OPTEK Technology
 2900 E. Plano Pkwy, Plano, TX 75074 | Ph: +1 972 323 2200
www.ttelectronics.com | sensors@ttelectronics.com

4-Pin LED Lamp (7.6 mm)

OVFSxxC8



Typical Electro-Optical Characteristics Curves — OVFSB7C8 (Blue) & OVFSG7C8 (Green)

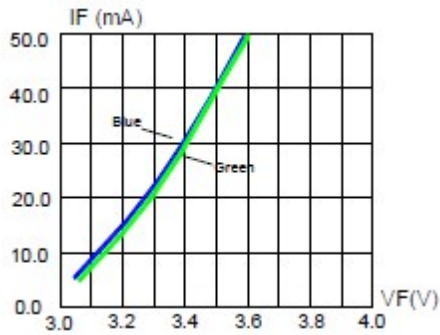

Forward Current vs Forward Voltage

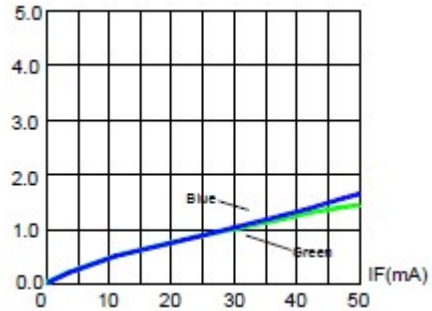

Relative Luminous Flux vs Forward Current

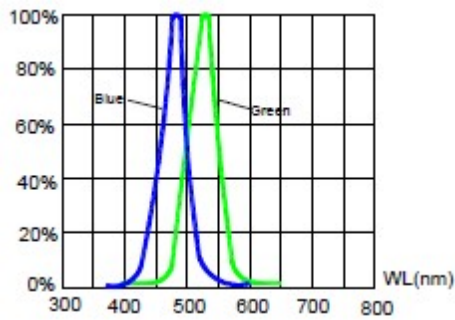

Relative Luminous Flux vs Wavelength

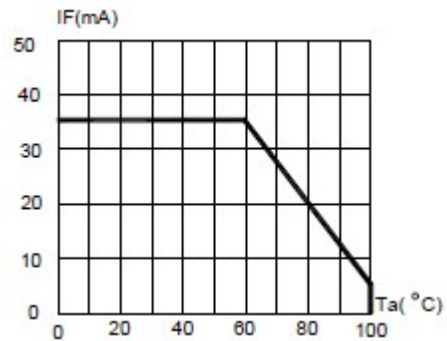

Maximum Forward DC Current vs Ambient Temperature

50% Power Angle: 70°

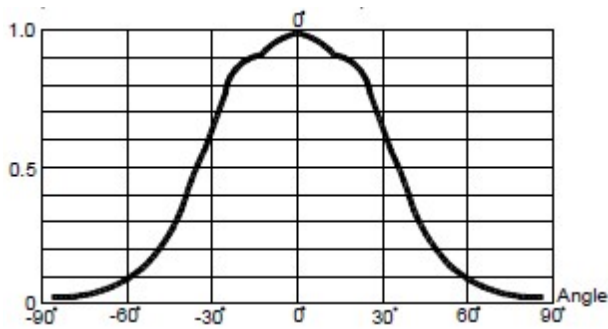

Angular Distribution

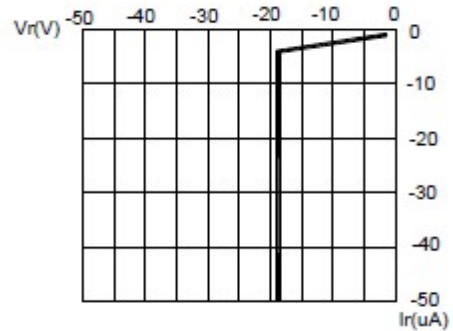

Reverse Current vs Reverse Voltage

General Note

TT Electronics reserves the right to make changes in product specification without notice or liability. All information is subject to TT Electronics' own data and is considered accurate at time of going to print.

TT Electronics | OPTEK Technology
 2900 E. Plano Pkwy, Plano, TX 75074 | Ph: +1 972 323 2200
www.ttelectronics.com | sensors@ttelectronics.com

4-Pin LED Lamp (7.6 mm)

OVFSxxC8



Typical Electro-Optical Characteristics Curves — OVFSAC8 (Amber) & OVFSRAC8 (Red)

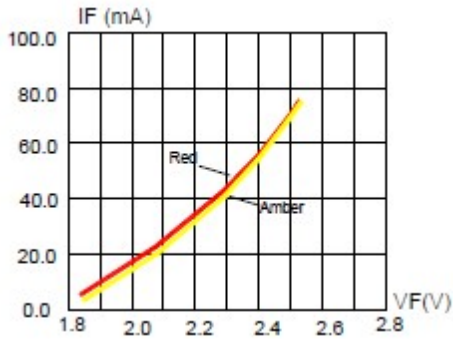

Forward Current vs Forward Voltage

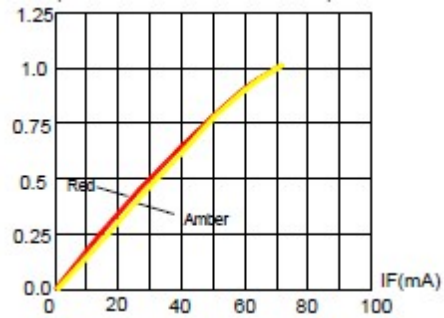

Relative Luminous Flux vs Forward Current

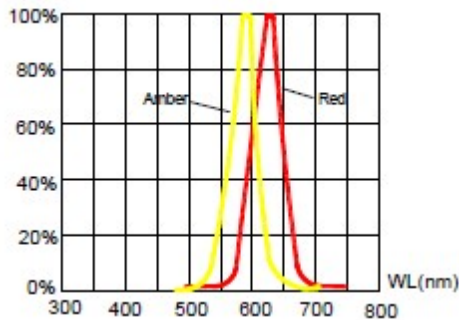

Relative Luminous Flux vs Wavelength

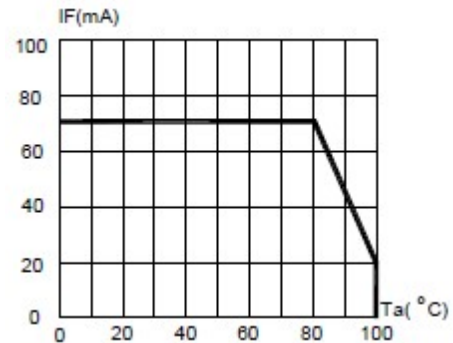

Maximum Forward DC Current vs Ambient Temperature

50% Power Angle: 100°

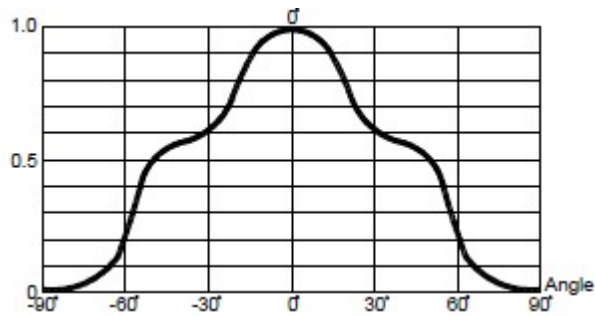

Angular Distribution

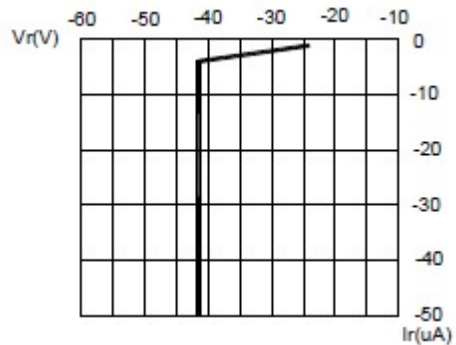

Reverse Current vs Reverse Voltage

General Note

TT Electronics reserves the right to make changes in product specification without notice or liability. All information is subject to TT Electronics' own data and is considered accurate at time of going to print.

TT Electronics | OPTEK Technology
 2900 E. Plano Pkwy, Plano, TX 75074 | Ph: +1 972 323 2200
www.ttelectronics.com | sensors@ttelectronics.com

4-Pin LED Lamp (7.6 mm)

OVFSxxC8



Typical Electro-Optical Characteristics Curves — OVFSW6C8 (White)

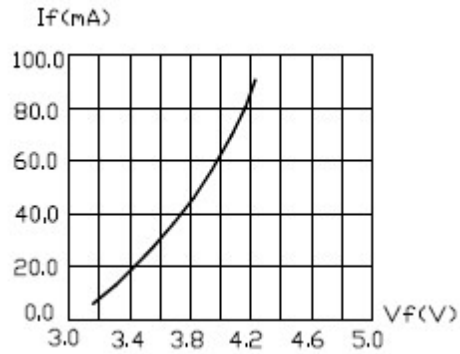

Forward Current vs Forward Voltage

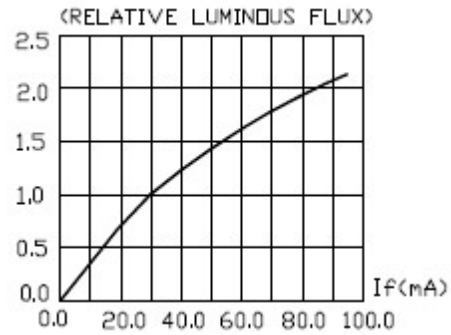

Relative Luminous Flux vs Forward Current

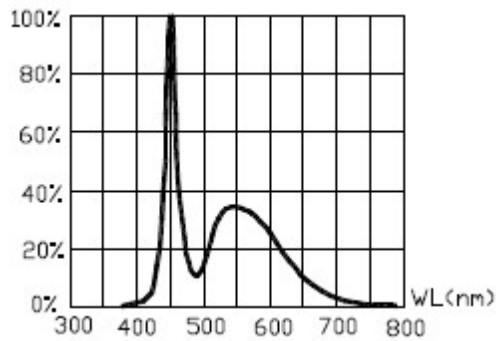

Relative Luminous Flux vs Wavelength

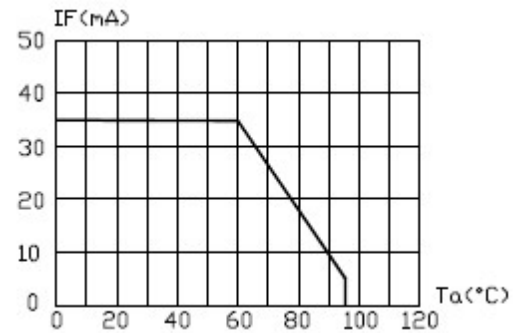

Maximum Forward DC Current vs Ambient

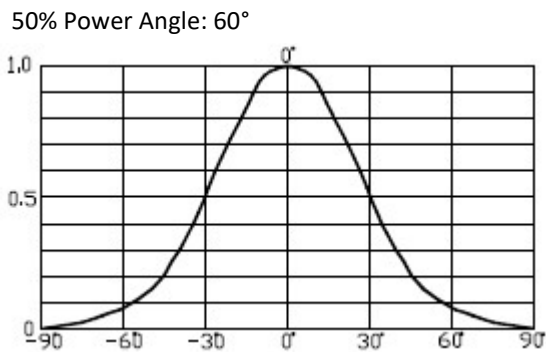

Angular Distribution

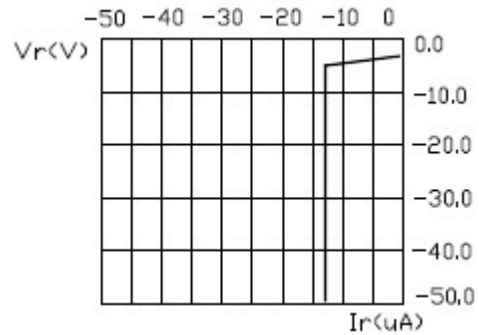

Reverse Current vs Reverse Voltage

General Note
TT Electronics reserves the right to make changes in product specification without notice or liability. All information is subject to TT Electronics' own data and is considered accurate at time of going to print.

4-Pin LED Lamp (7.6 mm)

OVFSxxC8



Packaging

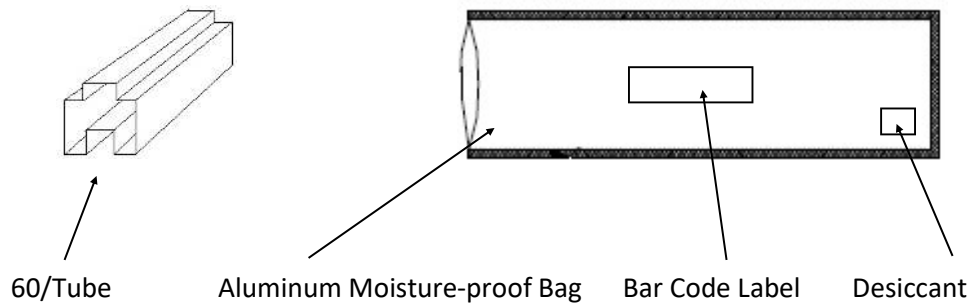

General Note
TT Electronics reserves the right to make changes in product specification without notice or liability. All information is subject to TT Electronics' own data and is considered accurate at time of going to print.

TT Electronics | OPTEK Technology
2900 E. Plano Pkwy, Plano, TX 75074 | Ph: +1 972 323 2200
www.ttelectronics.com | sensors@ttelectronics.com