

## SPECIFICATION CONTROL DRAWING

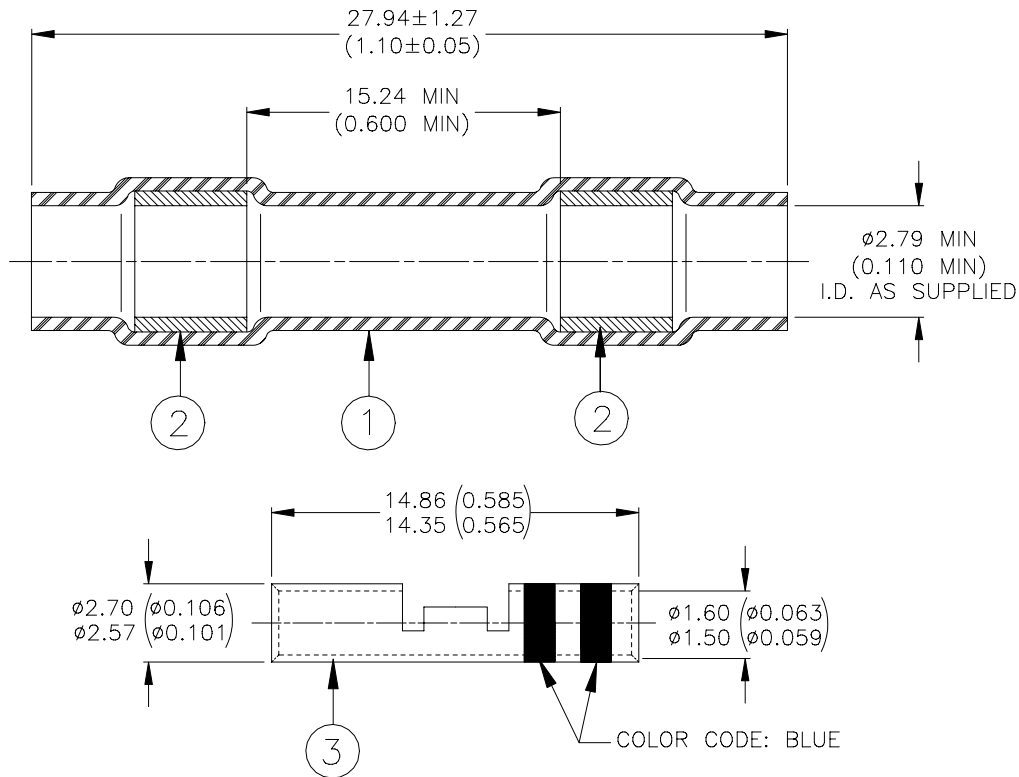

### MATERIALS

1. INSULATION SLEEVE: Heat-shrinkable, transparent blue, radiation cross-linked modified polyvinylidene fluoride.
2. MELTABLE INSERTS: Immersion resistant thermoplastic.
3. CRIMP SPLICER: Base Metal: Copper Alloy 101 or 102 per ASTM B-75.  
Plating: Tin, per MIL-T-10727, Type 1.

### INSTALLATION DATA:

Conductor size range of Crimp Splicer: Minimum – 22, Maximum – 18  
 Insulation Diameters in which part will seal: Minimum – 0.64 (0.025), Maximum – 2.79 (0.110)

### APPLICATION

1. These parts are designed to provide immersion resistant in-line splices of 1 to 1, 1 to 2 or 2 to 2 with wires falling within size range listed above, and having insulations rated for at least 125°C.
2. Crimp splicer may be installed with Raychem AD-1377 Crimp Tool using the blue nest marked 16-20.
3. Parts will meet requirements of U.S. Military Specification MIL-S-81824/1.
4. Acceptance sampling shall be accordance with Paragraph 4.6.1 of MIL-S-81824.
5. Packing and packaging shall be accordance with Section 5, Level C, of MIL-S-81824.
6. This document takes precedence over documents referenced herein.
7. For assembly procedure, see Raychem Process Standard RCPS 200-20.

<b>Raychem Interconnect</b> <small>a division of tyco Electronics</small> 300 Constitution Drive Menlo Park, CA 94025, USA		THERMOFIT DEVICES	TITLE : <b>IN-LINE SPLICE SEALING SYSTEM</b>				
UNLESS OTHERWISE SPECIFIED DIMENSIONS ARE IN MILLIMETERS. INCHES DIMENSIONS ARE BETWEEN BRACKETS.			DOCUMENT NO.: <b>D-436-0147</b>				
TOLERANCES: 0.00 N/A 0.0 N/A 0 N/A	ANGLES: N/A  ROUGHNESS IN MICRON	Raychem reserves the right to amend this drawing at any time. Users should evaluate the suitability of the product for their application.	DCR NUMBER: <b>D001282</b>	REPLACES: <b>N/A</b>			
DRAWN BY: M. FORONDA	DATE: 14-Nov.-00	PROD. REV. A	DOC ISSUE: 1	SCALE: None	SIZE: A	SHEET: 1 of 1	

If this document is printed it becomes uncontrolled. Check for the latest revision.