

O6E205

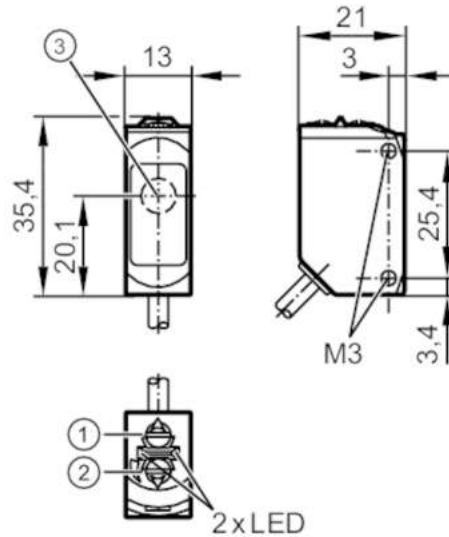

Through-beam sensor receiver

O6E-FNKG/0,30m/US



- 1 output function switch
- 2 potentiometer sensitivity
- 3 Light incidence



Product characteristics

Type of light	red light
Housing	rectangular

Application

Function principle	Through-beam sensor
--------------------	---------------------

Electrical data

Operating voltage	[V]	10...30 DC
Current consumption	[mA]	7; ((24 V))
Protection class		III
Reverse polarity protection		yes
Type of light		red light
Wave length	[nm]	633

Outputs

Electrical design		NPN
Output function		light-on/dark-on mode; (selectable)
Max. voltage drop switching output DC	[V]	2.5
Permanent current rating of switching output DC	[mA]	100
Switching frequency DC	[Hz]	1000
Short-circuit protection		yes
Type of short-circuit protection		pulsed

Detection zone

Transmitter / receiver	receiver
------------------------	----------

O6E205



Through-beam sensor receiver

O6E-FNKG/0,30m/US

Range	[m]	< 10
Range adjustable		yes

Operating conditions

Ambient temperature	[°C]	-25...60
Protection		IP 65; IP 67

Tests / approvals

EMC		EN 60947-5-2
MTTF	[years]	956
UL approval		UL Approval no. E012

Mechanical data

Weight	[g]	32.9
Housing		rectangular
Dimensions	[mm]	35.4 x 13 x 21
Materials		housing: ABS; PPSU; Sealing: EPDM
Lens material		PMMA
Lens alignment		side lens
Tightening torque	[Nm]	0.5

Displays / operating elements

Display	switching status	1 x LED, yellow
	operation	1 x LED, green

Remarks

Remarks	operating voltage "supply class 2" according to cULus
Pack quantity	1 pcs.

Electrical connection

Cable: 0.3 m, PUR; 3 x 0.25 mm²

Connector: 1 x M12; coding: A





Through-beam sensor receiver

O6E-FNKG/0,30m/US

Connection

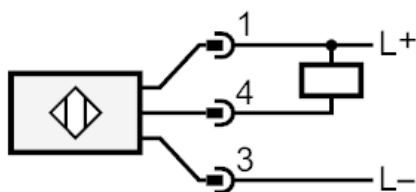

Diagrams and graphs

excess gain graph

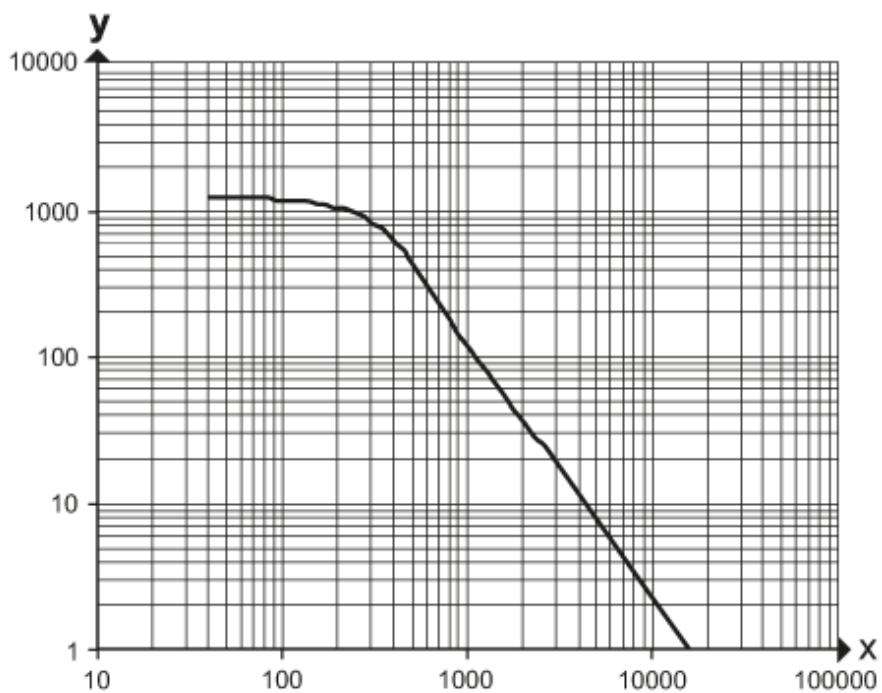

x: distance [mm]

y: excess gain factor