

Low consumption voltage and current controller for battery chargers and adapters

Datasheet - production data

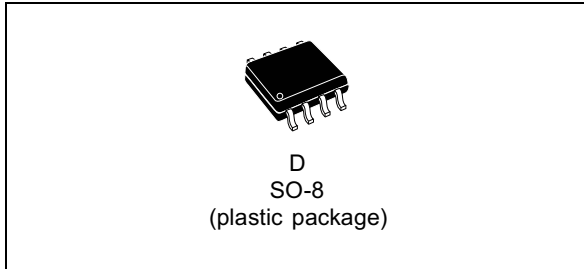

Features

- Constant voltage and constant current control
- Low consumption
- Low voltage operation
- Low external component count
- Current sink output stage
- Easy compensation
- High ac mains voltage rejection
- 2 kV ESD protection (HBM)

Voltage reference

- Fixed output voltage reference 1.25 V
- 0.5% and 1% voltage precision

Applications

- Adapters
- Battery chargers

Description

The TSM1014 is a highly integrated solution for SMPS applications requiring CV (constant voltage) and CC (constant current) mode.

The TSM1014 device integrates one voltage reference and two operational amplifiers.

The voltage reference combined with one operational amplifier makes it an ideal voltage controller. The other operational amplifier, combined with few external resistors and the voltage reference, can be used as a current limiter.

Figure 1. Pin connections (top view)

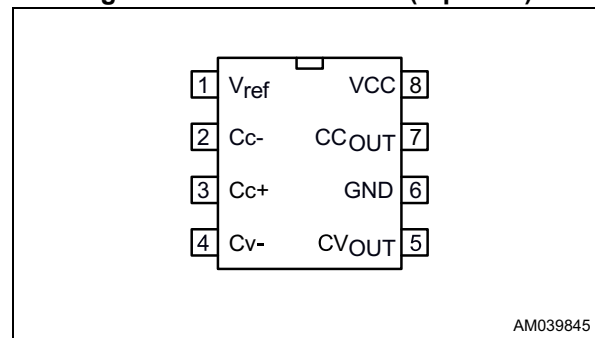

Table 1. Order codes

Part number	Temperature range	Package	Packaging	V _{Ref} (%)	Marking
TSM1014ID	-40 to 105 °C	SO-8	Tube	1	M1014
TSM1014IDT			Tape and reel	1	M1014
TSM1014AID			Tube	0.5	M1014A
TSM1014AIDT			Tape and reel	0.5	M1014A

Contents

- 1 Pin descriptions 3**
- 2 Absolute maximum ratings 3**
- 3 Operating conditions 4**
- 4 Electrical characteristics 4**
- 5 Internal schematic 6**
- 6 Principles of operation and application tips 7**
 - 6.1 Voltage control 7
 - 6.2 Current control 7
 - 6.3 Compensation 8
 - 6.4 Start-up and short-circuit conditions 9
 - 6.5 Voltage clamp 9
- 7 Package information 11**
 - 7.1 SO-8 package information 11
- 8 Revision history 13**

1 Pin descriptions

Table 2 gives the pin descriptions for the SO-8 package.

Table 2. Pin descriptions

Name	Pin no.	Type	Function
V_{Ref}	1	Analog output	Voltage reference
Cc-	2	Analog input	Input pin of the operational amplifier
Cc+	3	Analog input	Input pin of the operational amplifier
CV-	4	Analog input	Input pin of the operational amplifier
CV _{OUT}	5	Analog output	Output of the operational amplifier
GND	6	Power supply	Ground line. 0 V reference for all voltages.
CC _{OUT}	7	Analog output	Output of the operational amplifier
VCC	8	Power supply	Power supply line

2 Absolute maximum ratings

Table 3. Absolute maximum ratings

Symbol	DC supply voltage	Value	Unit
VCC	DC supply voltage (50 mA =< I _{CC})	-0.3V to Vz	V
V _i	Input voltage	-0.3 to VCC	V
T _{oper}	Operational temperature	-40 to 105	°C
T _{stg}	Storage temperature	-55 to 150	°C
T _j	Junction temperature	150	°C
I _{ref}	Voltage reference output current	2.5	mA
ESD	Electrostatic discharge	2	kV
R _{thja}	Thermal resistance junction to ambient SO8 package	175	°C/W

3 Operating conditions

Table 4. Operating conditions

Symbol	Parameter	Value	Unit
VCC	DC supply conditions	4.5 to Vz	V
T _{oper}	Operational temperature	-40 to 105	°C

4 Electrical characteristics

$T_{amb} = 25\text{ °C}$ and $VCC = +18\text{ V}$ (unless otherwise specified).

Table 5. Electrical characteristics

Symbol	Parameter	Test condition	Min.	Typ.	Max.	Unit
Total current consumption						
I_{CC}	Total supply current, excluding current in voltage reference ⁽¹⁾	$VCC = 18\text{ V}$, no load $T_{min.} < T_{amb} < T_{max.}$		100	180	μA
V_Z	VCC clamp voltage	$I_{CC} = 50\text{ mA}$		28		V
Operator 1: Op Amp with non-inverting input connected to the internal V_{Ref}						
$V_{Ref} + V_{io}$	Input offset voltage + voltage reference TSM1014 TSM1014A	$T_{amb} = 25\text{ °C}$ $T_{min.} \leq T_{amb} \leq T_{max.}$ $T_{amb} = 25\text{ °C}$ $T_{min.} \leq T_{amb} \leq T_{max.}$		1.251 1.25	1.266 1.279 1.258 1.267	V
DV_{io}	Input offset voltage drift			7		$\mu\text{V}/\text{°C}$
Operator 2						
V_{io}	Input offset voltage TSM1014 TSM1014A	$T_{amb} = 25\text{ °C}$ $T_{min.} \leq T_{amb} \leq T_{max.}$ $T_{amb} = 25\text{ °C}$ $T_{min.} \leq T_{amb} \leq T_{max.}$		1 0.5	4 5 2 3	mV
DV_{io}	Input offset voltage drift			7		$\mu\text{V}/\text{°C}$
I_{ib}	Input bias current	$T_{amb} = 25\text{ °C}$ $T_{min.} \leq T_{amb} \leq T_{max.}$		20 50	150 200	nA
SVR	Supply voltage rejection ration	$VCC = 4.5\text{ V to }28\text{ V}$	65	100		dB
V_{icm}	Input common mode voltage range		0		$VCC - 1.5$	V
CMR	Common mode rejection ratio	$T_{amb} = 25\text{ °C}$ $T_{min.} \leq T_{amb} \leq T_{max.}$	70 60	85		dB
Output stage						
Gm	Transconduction gain. Sink current only ⁽²⁾	$T_{amb} = 25\text{ °C}$ $T_{min.} \leq T_{amb} \leq T_{max.}$	0.5	1 1		mA/mV
V_{ol}	Low output voltage at 5 mA sinking current	$T_{min.} \leq T_{amb} \leq T_{max.}$		250	400	mV
I_{os}	Output short-circuit current. Output to ($VCC - 0.6\text{ V}$). Sink current only.	$T_{amb} = 25\text{ °C}$ $T_{min.} \leq T_{amb} \leq T_{max.}$	6 5	10		mA

Table 5. Electrical characteristics (continued)

Symbol	Parameter	Test condition	Min.	Typ.	Max.	Unit
Voltage reference						
V_{Ref}	Reference input voltage TSM1014 1% precision	$T_{amb} = 25\text{ }^{\circ}\text{C}$ $T_{min.} \leq T_{amb} \leq T_{max.}$	1.238 1.225	1.25	1.262 1.273	V
	TSM1014A 0.5% precision	$T_{amb} = 25\text{ }^{\circ}\text{C}$ $T_{min.} \leq T_{amb} \leq T_{max.}$	1.244 1.237	1.25	1.256 1.261	
ΔV_{Ref}	Reference input voltage deviation over the temperature range	$T_{min.} \leq T_{amb} \leq T_{max.}$		20	30	mV
RegLine	Reference input voltage deviation over the VCC range	$I_{load} = 1\text{ mA}$			20	mV
RegLoad	Reference input voltage deviation over the output current	$V_{CC} = 18\text{ V}$, $0 < I_{load} < 2.5\text{ mA}$			10	mV

1. Test conditions: pin 2 and 6 connected to GND, pin 4 and 5 connected to 1.25 V, pin 3 connected to 200 mV.
2. The current depends on the voltage difference between the negative and the positive inputs of the amplifier. If the voltage on the minus input is 1 mV higher than the positive amplifier, the sinking current at the output OUT will be increased by $G_m * 1\text{ mA}$.

5 Internal schematic

Figure 2. Internal schematic

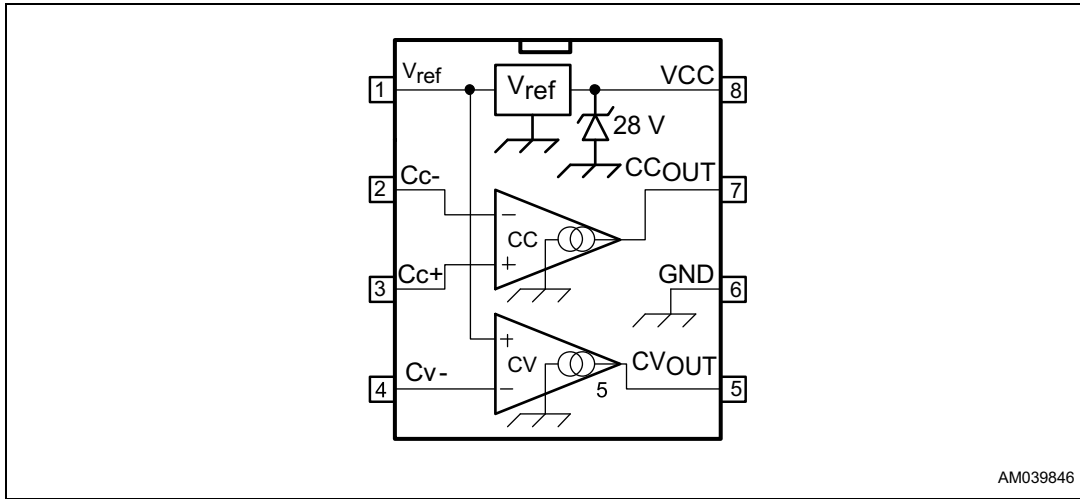

AM039846

Figure 3. Typical adapter or battery charger application using TSM1014

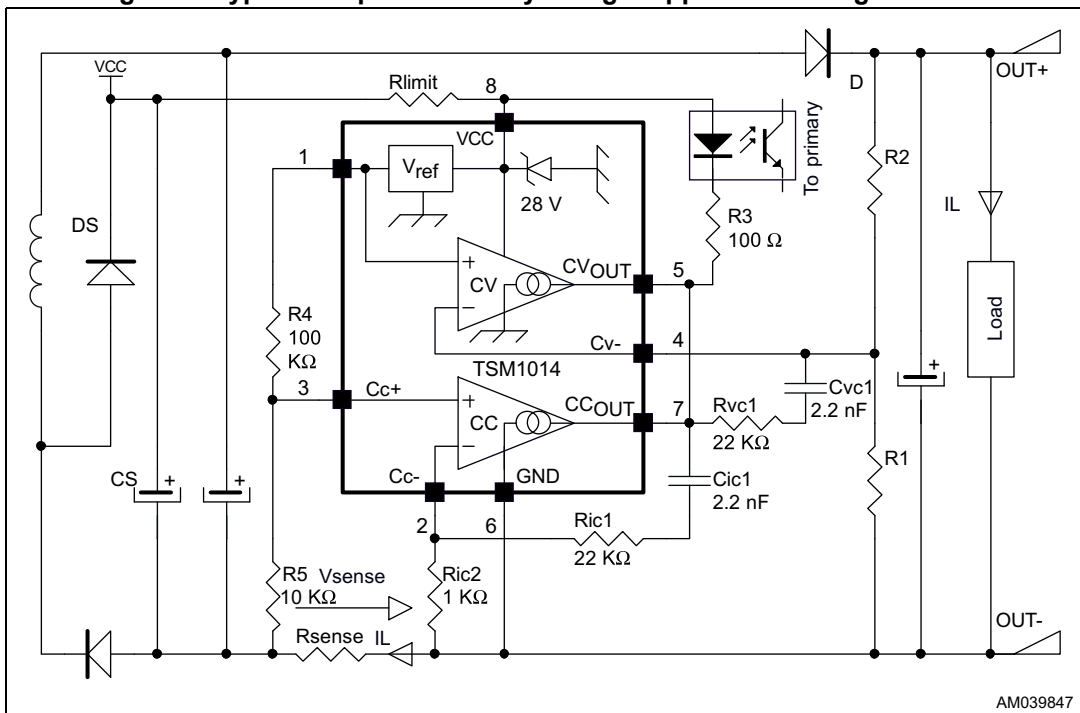

AM039847

In the application schematic shown in [Figure 3](#), the TSM1014 is used on the secondary side of a flyback adapter (or battery charger) to provide an accurate voltage and current control. The above feedback loop is made with an optocoupler.

6 Principles of operation and application tips

6.1 Voltage control

The voltage loop is controlled via a first transconductance operational amplifier, the resistor bridge $R1$, $R2$, and the optocoupler which is directly connected to the output.

The relation between the values of $R1$ and $R2$ should be chosen as written in [Equation 1](#):

Equation 1

$$R1 = R2 \times V_{Ref} / (V_{out} - V_{Ref})$$

where V_{out} is the desired output voltage.

To avoid the discharge of the load, the resistor bridge $R1$, $R2$ should be highly resistive. For this type of application, a total value of 100 K Ω (or more) would be appropriate for the resistors $R1$ and $R2$.

As an example, with $R2 = 100$ K Ω , $V_{out} = 4.10$ V, $V_{Ref} = 1.210$ V, then $R1 = 41.9$ K Ω .

Note that if the low drop diode is inserted between the load and the voltage regulation resistor bridge to avoid current flowing from the load through the resistor bridge, this drop should be taken into account in the above calculations by replacing V_{out} by $(V_{out} + V_{drop})$.

6.2 Current control

The current loop is controlled via the second transconductance operational amplifier, the sense resistor R_{sense} , and the optocoupler.

V_{sense} threshold is achieved externally by a resistor bridge tied to the V_{Ref} voltage reference. Its middle point is tied to the positive input of the current control operational amplifier, and its foot is to be connected to lower potential point of the sense resistor as shown in [Figure 4](#). The resistors of this bridge are matched to provide the best precision possible.

The control equation verifies:

Equation 2

$$R_{sense} \times I_{lim} = V_{sense}$$

$$V_{sense} = \frac{R_5 \cdot V_{ref}}{(R_4 + R_5)}$$

Equation 3

$$I_{lim} = \frac{R_5 \cdot V_{ref} \cdot R_{sense}}{(R_4 + R_5)}$$

where I_{lim} is the desired limited current, and V_{sense} is the threshold voltage for the current control loop.

Note that the R_{sense} resistor should be chosen taking into account the maximum dissipation (P_{lim}) through it during full load operation.

Equation 4

$$P_{lim} = I_{lim} \times V_{sense}$$

Therefore, for most adapter and battery charger applications, a quarter-watt, or half-watt resistor to make the current sensing function is sufficient.

The current sinking outputs of the two transconductance operational amplifiers are common (to the output of the IC). This makes an ORing function which ensures that whenever the current or the voltage reaches too high values, the optocoupler is activated.

The relation between the controlled current and the controlled output voltage can be described with a square characteristic as shown in the following V/I output power graph.

Figure 4. Output voltage versus output current

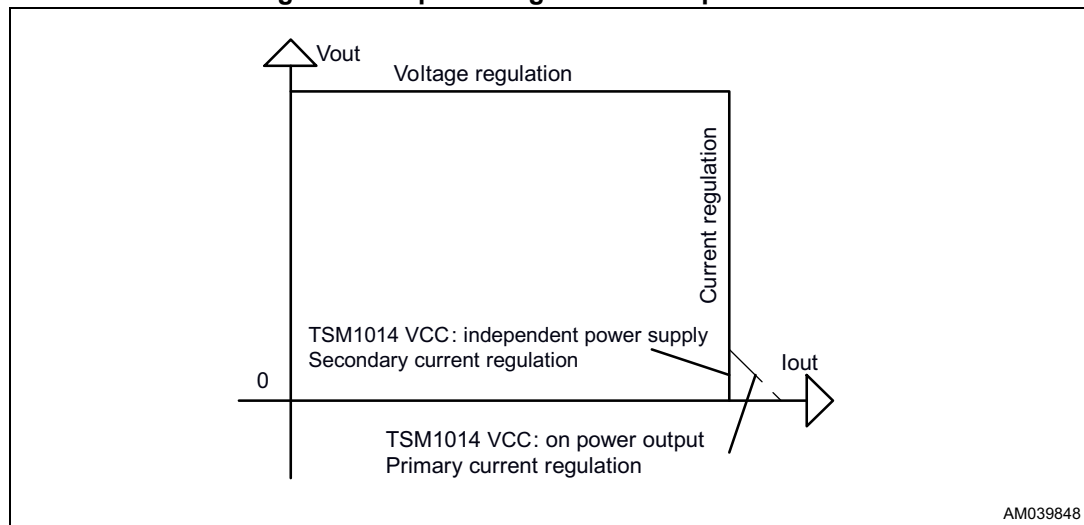

6.3 Compensation

The voltage control transconductance operational amplifier can be fully compensated. Both its output and negative input are directly accessible for external compensation components.

An example of a suitable voltage control compensation network is shown in [Figure 3 on page 3](#). It consists of a capacitor $C_{vc1} = 2.2 \text{ nF}$ and a resistor $R_{cv1} = 22 \text{ K}\Omega$ in series.

The current control transconductance operational amplifier can be fully compensated. Both of its output and negative input are directly accessible for external compensation components.

An example of a suitable current control compensation network is also shown in [Figure 3](#). It consists of a capacitor $C_{ic1} = 2.2 \text{ nF}$ and a resistor $R_{ic1} = 22 \text{ K}\Omega$ in series.

6.4 Start-up and short-circuit conditions

Under start-up or short-circuit conditions the TSM1014 is not provided with a high enough supply voltage. This is due to the fact that the chip has its power supply line in common with the power supply line of the system.

Therefore, the current limitation can only be ensured by the primary PWM module, which should be chosen accordingly.

If the primary current limitation is considered not to be precise enough for the application, then a sufficient supply for the TSM1014 has to be ensured under all conditions. For this, it would be necessary to add some circuitry to supply the chip with a separate power line. This can be achieved in a number of ways, including putting an additional winding on the transformer.

6.5 Voltage clamp

Figure 6 shows how to realize a low-cost power supply for the TSM1014 (with no additional windings). Please pay attention to the fact that in the particular case presented here, this low-cost power supply can reach voltages as high as twice the voltage of the regulated line. Since the absolute maximum rating of the TSM1014 supply voltage is 28 V. In the aim to protect the TSM1014 against such high voltage values an internal Zener clamp is integrated (see *Figure 5*).

Equation 5

$$R_{limit} = (V_{CC} - V_z) \cdot I_{Vz}$$

Figure 5. Clamp voltage

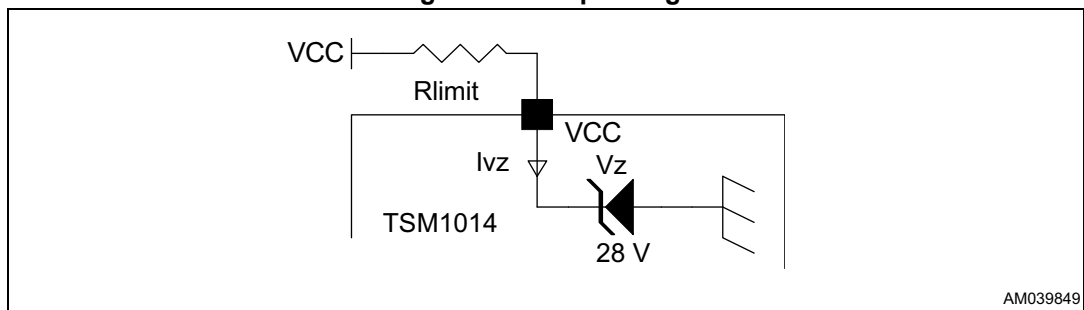
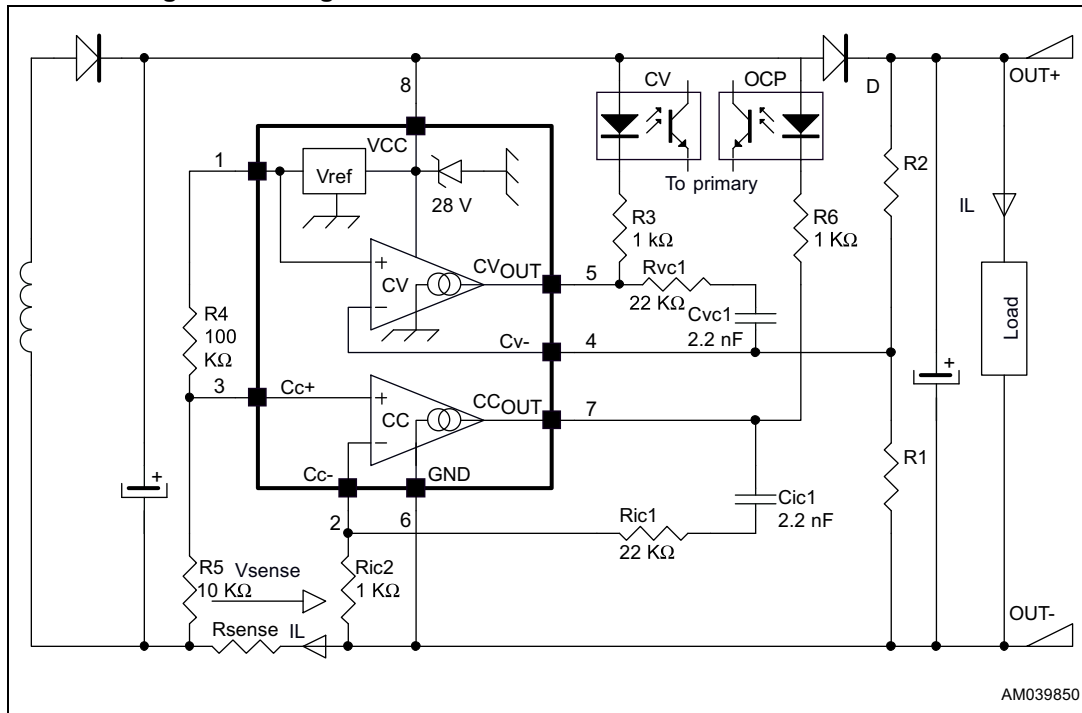

Figure 6. Voltage controller and overcurrent detection schematic



AM039850

7 Package information

In order to meet environmental requirements, ST offers these devices in different grades of ECOPACK® packages, depending on their level of environmental compliance. ECOPACK specifications, grade definitions and product status are available at: www.st.com. ECOPACK is an ST trademark.

7.1 SO-8 package information

Figure 7. SO-8 package outline

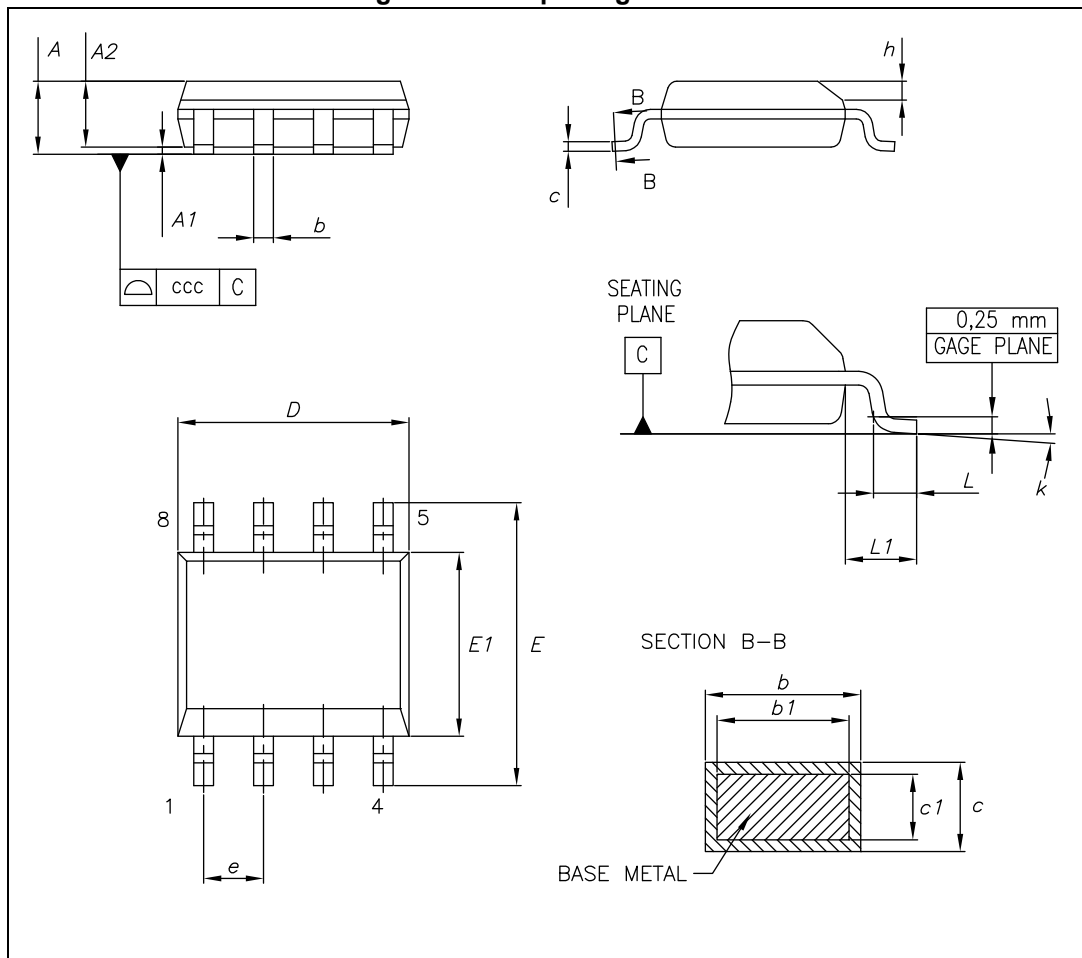

Table 6. SO-8 package mechanical data

Symbol	Dimensions (mm)		
	Min.	Typ.	Max.
A			1.75
A1	0.10		0.25
A2	1.25		
b	0.28		0.48
c	0.17		0.23
D ⁽¹⁾	4.80	4.90	5.00
E	5.80	6.00	6.20
E1 ⁽²⁾	3.80	3.90	4.00
e		1.27	
h	0.25		0.50
L	0.40		1.27
L1		1.04	
k	0°		8°
ccc			0.10

1. Dimension "D" does not include mold flash, protrusions or gate burrs. Mold flash, protrusions or gate burrs shall not exceed 0.15 mm in total (both sides).
2. Dimension "E1" does not include interlead flash or protrusions. Interlead flash or protrusions shall not exceed 0.25 mm per side.

8 Revision history

Table 7. Document revision history

Date	Revision	Changes
01 -Jul-2004	1	Initial release.
03-Mar-2016	2	Removed Mini SO8 package from the whole document. Minor modifications throughout document.
15-Apr-2016	3	Updated Section 7: Package information on page 11 (replaced Figure 7 on page 11 by new figure, updated Table 6 on page 12).

IMPORTANT NOTICE – PLEASE READ CAREFULLY

STMicroelectronics NV and its subsidiaries ("ST") reserve the right to make changes, corrections, enhancements, modifications, and improvements to ST products and/or to this document at any time without notice. Purchasers should obtain the latest relevant information on ST products before placing orders. ST products are sold pursuant to ST's terms and conditions of sale in place at the time of order acknowledgement.

Purchasers are solely responsible for the choice, selection, and use of ST products and ST assumes no liability for application assistance or the design of Purchasers' products.

No license, express or implied, to any intellectual property right is granted by ST herein.

Resale of ST products with provisions different from the information set forth herein shall void any warranty granted by ST for such product.

ST and the ST logo are trademarks of ST. All other product or service names are the property of their respective owners.

Information in this document supersedes and replaces information previously supplied in any prior versions of this document.

© 2016 STMicroelectronics – All rights reserved