

28J0138-11R-10

PHYSICAL DIMENSIONS:

A	3.51 [.138]	+	0.13 [.005]
B	25.4 [1.00]	+	0.51 [.020]
C	4.45 [.175]	+	0.20 [.008]
		-	0.80 [.031]
D	3.81 [.150]	+	0.20 [.008]

WIRE DIMENSIONS:

T1	0.64 [.025]	+	0.05 [.002]
----	-------------	---	-------------

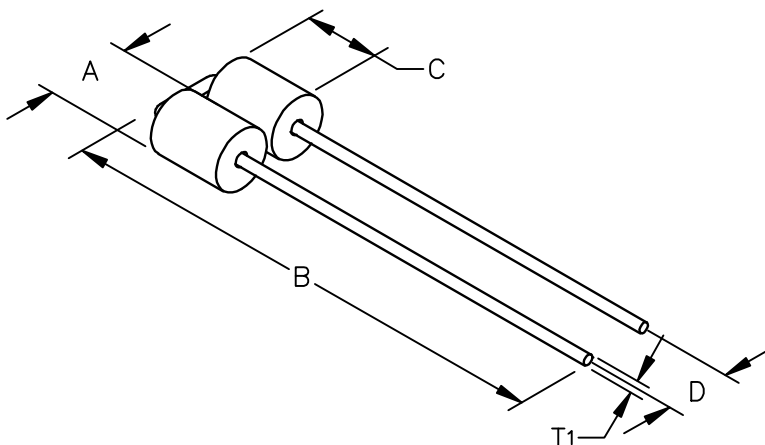

ELECTRICAL CHARACTERISTICS:

	Z @ 100MHz (Ω)	DCR (Ω)	Rated Current
Nominal	143	-	-
Minimum	107	-	-
Maximum	-	0.01	5,000 mA



[Z], R AND XL vs FREQUENCY

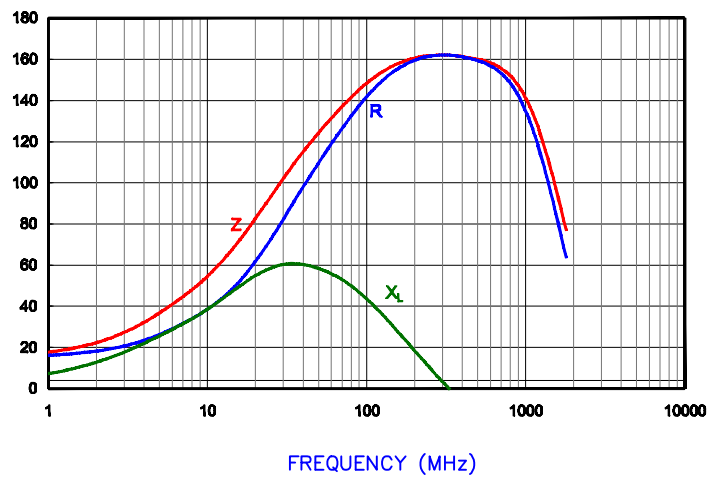

Z **R** **X_L**

**UNCONTROLLED
DOCUMENT**

NOTES: UNLESS OTHERWISE SPECIFIED

- COMPONENTS SHOULD BE ADEQUATELY PREHEATED BEFORE SOLDERING.
- WIRE: C10200 OXYGEN FREE COPPER (99.95 MIN.) 22AWG (.025 DIA.)
- PLATING: 100% TIN $5\mu \pm 2\mu$ [$200\mu\text{in} \pm 80\mu\text{in}$]
- WEIGHT/K: .46 #

DIMENSIONS ARE IN mm (INCHES).				THIS DOCUMENT CONTAINS INFORMATION WHICH IS PROPRIETARY AND CONFIDENTIAL TO STEWARD. NO PRODUCTION OR PUBLICATION OF THIS DOCUMENT IN WHOLE OR IN PART SHALL BE MADE WITHOUT WRITTEN AUTHORIZATION FROM STEWARD.			
H	ADD ROHS & PB SYMBOLS CHG LOGO	04/20/07	JRK				
G	CHANGE P/N TO -10	12/09/03	JRK				
F	CHANGE WIRE NOTE ADD PLATING NOTE	04/07/03	JRK				
E	REMOVE NOTE # 1	03/21/02	JRK				
D	UPDATE PRINT FORMAT, ADD Z CURVE REMOVE SHEETS 3 & 4 ADDED NOTES	04/30/99	IS				
PROJECT/PART NUMBER:				REV	PART TYPE:	DRAWN BY:	
28J0138-11R-10				H	ASSEMBLY	JAZ	
C	ADDED IMPEDANCE SPEC	04/25/95	JBE	DATE:	08/03/92	SCALE:	NTS
B	CHANGED LENGTH	03/18/94	JAZ	CAD #		SHEET:	
REV	DESCRIPTION	DATE	INT	28J0138-11R-10-H		TOOL #	B0138
						2 OF 3	