

4

3

2

1

THIS DRAWING IS UNPUBLISHED  
 RELEASED FOR PUBLICATION  
 © COPYRIGHT - By - ALL RIGHTS RESERVED.

REVISIONS				
P	LTR	DESCRIPTION	DATE	DWN APVD
	D5	OBSOLETE 1734531-9	17OCT19	AY PS

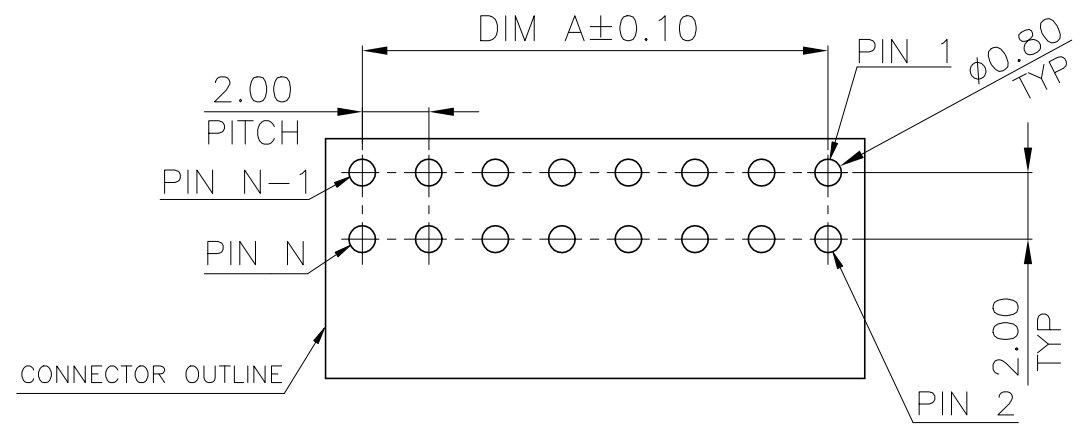
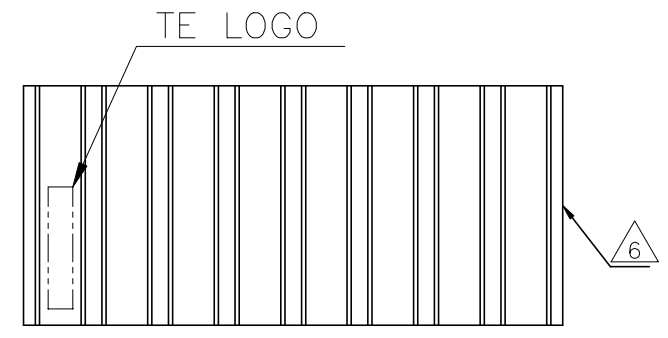

DIM A	DIM B	POSITION NUMBER	PART NUMBER
OBSOLETE	78.00	80.20	80 8- -0
	76.00	78.20	78 7- -8
	74.00	76.20	76 7- -6
	72.00	74.20	74 7- -4
	70.00	72.20	72 7- -2
	68.00	70.20	70 7- -0
	66.00	68.20	68 6- -8
	64.00	66.20	66 6- -6
	62.00	64.20	64 6- -4
	60.00	62.20	62 6- -2
	58.00	60.20	60 6- -0
	56.00	58.20	58 5- -8
	54.00	56.20	56 5- -6
	52.00	54.20	54 5- -4
OBSOLETE	50.00	52.20	52 5- -2
	48.00	50.20	50 5- -0
	46.00	48.20	48 4- -8
	44.00	46.20	46 4- -6
	42.00	44.20	44 4- -4
	40.00	42.20	42 4- -2
	38.00	40.20	40 4- -0
	36.00	38.20	38 3- -8
OBSOLETE	34.00	36.20	36 3- -6
	32.00	34.20	34 3- -4
	30.00	32.20	32 3- -2
	28.00	30.20	30 3- -0
OBSOLETE	26.00	28.20	28 2- -8
	24.00	26.20	26 2- -6
	22.00	24.20	24 2- -4
	20.00	22.20	22 2- -2
	18.00	20.20	20 2- -0
	16.00	18.20	18 1- -8
	14.00	16.20	16 1- -6
	12.00	14.20	14 1- -4
	10.00	12.20	12 1- -2
	8.00	10.20	10 1- -0
OBSOLETE	6.00	8.20	8 1734531-8
	4.00	6.20	6 1734531-6
	2.00	4.20	4 1734531-4

5 RECOMMENDED PCB LAYOUT  
 TOLERANCE ± 0.05 (TOP VIEW)

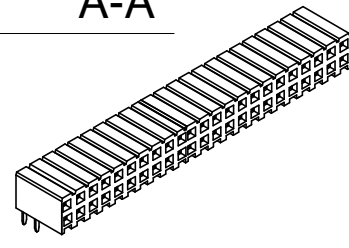
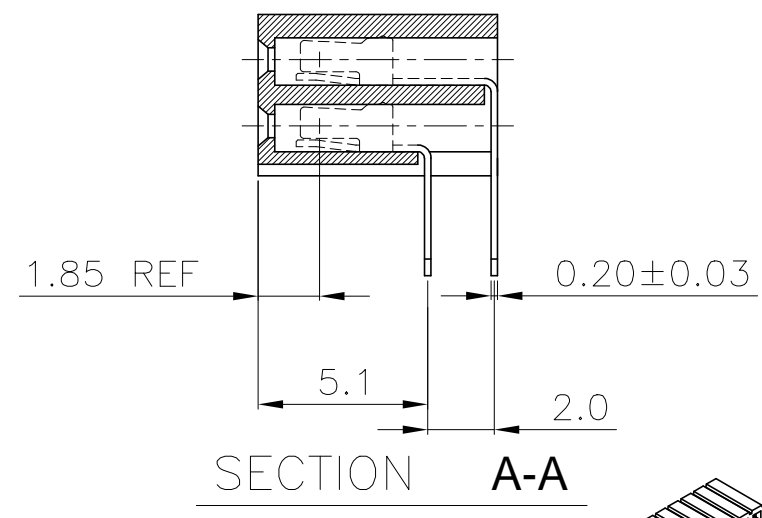
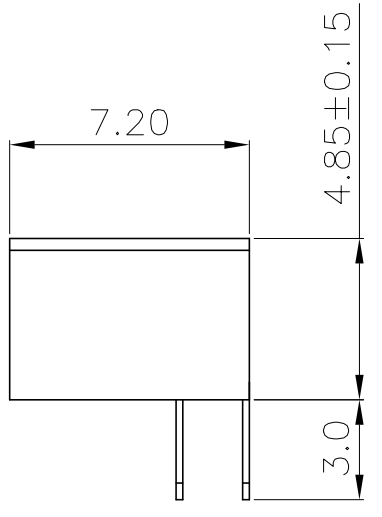
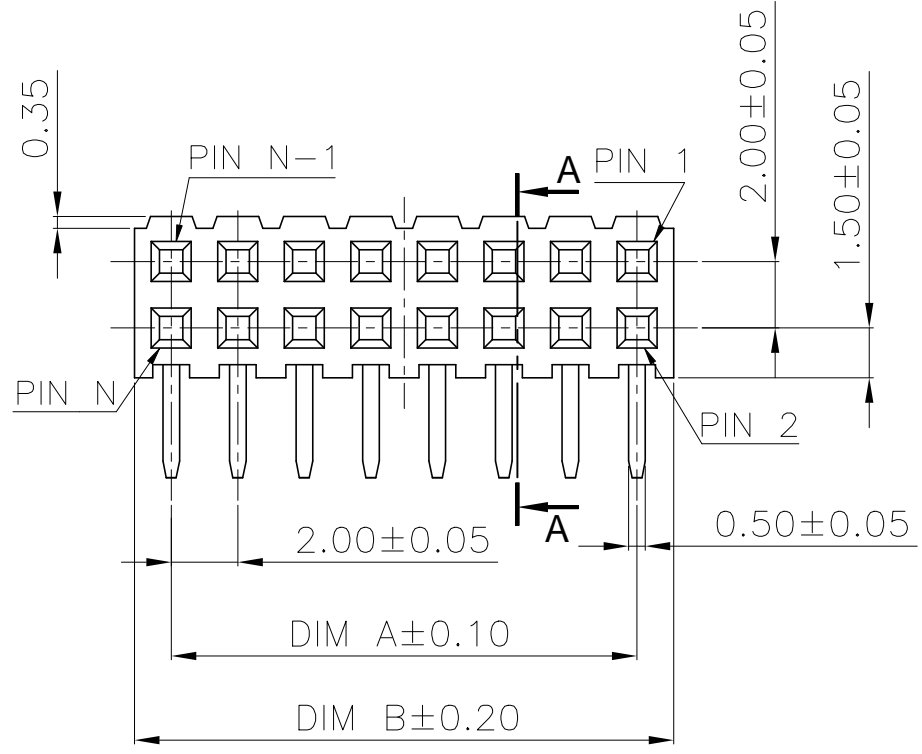

NOTE :

1 MATERIAL :  
 HOUSING : THERMOPLASTIC, UL94V-0, BLACK COLOR  
 CONTACT : PHOSPHOR BRONZE, THICKNESS=0.20mm.

2 FINISH :  
 CONTACT: 0.254mm [10m"] MIN. GOLD PLATED ON CONTACT AREA  
 2.54mm [100m"] MIN. BRIGHT TIN PLATED ON SOLDER TAIL,  
 1.27mm [50m"] MIN. NICKEL UNDERPLATED OVER ALL

3 APPLICATION :  
 SOLDER TAIL LENGTH 2.6 FOR PCB THICKNESS 1.6±0.1

4 WAVE SOLDER CAPABLE TO 265°C PER TE SPEC 109-202, CONDITION B

5 NO CUMULATIVE TOLERANCE

6 DATECODE: YY WW D \*  
 ASS'Y LINE NO.  
 DAY  
 WEEK CODE  
 YEAR

7 QUALIFICATION TEST REPORT: 501-57197

THIS DRAWING IS A CONTROLLED DOCUMENT.		DWN	O.HU	05JUL2005	 TE Connectivity Ltd.
DIMENSIONS: mm		CHK	S.HOU	05JUL2005	
TOLERANCES UNLESS OTHERWISE SPECIFIED:		APVD	W.J.KE	05JUL2005	
0 PLC ± 0.5 1 PLC ± 0.2 2 PLC ± 0.1 3 PLC ± 0.05 4 PLC ± - ANGLES ± 3°		PRODUCT SPEC		NAME	
MATERIAL 1		FINISH 2		108-57197	
		APPLICATION SPEC		AMPMODU 2.0mm PITCH, RCPT CONN., RIGHT-ANGLE, MOUNT TYPE	
		WEIGHT -		SIZE	A3
		CUSTOMER DRAWING		CAGE CODE	00779
				DRAWING NO	1734531
				RESTRICTED TO	-
				SCALE	1:1
				SHEET	1 OF 3
				REV	D5

4

3

2

1

THIS DRAWING IS UNPUBLISHED  
 RELEASED FOR PUBLICATION  
 ALL RIGHTS RESERVED.

REVISIONS					
P	LTR	DESCRIPTION	DATE	DWN	APVD
-	-	SEE SHEET 1	-	-	-

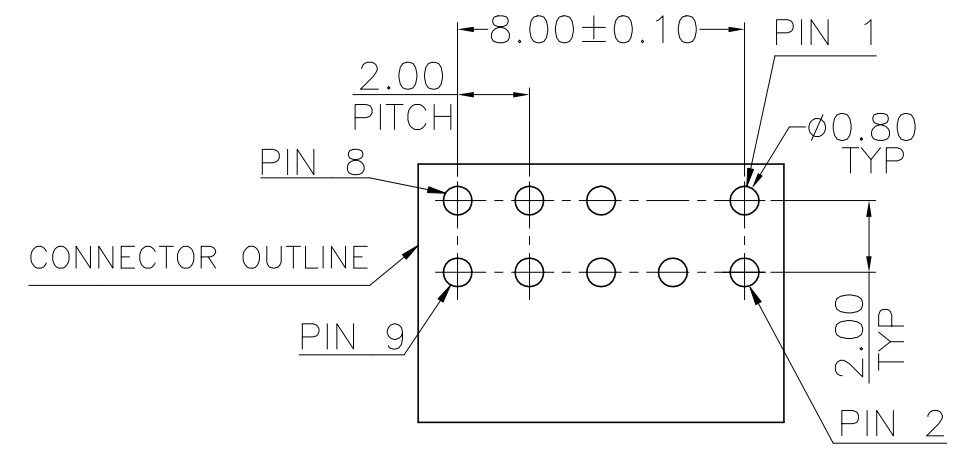
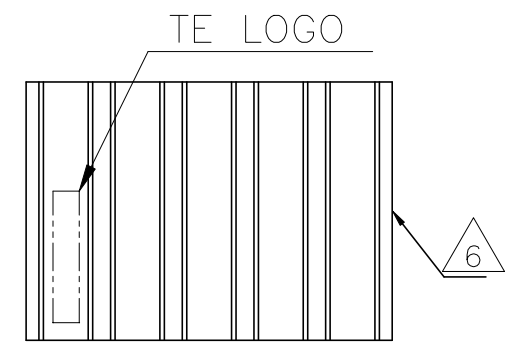

△ 5 RECOMMENDED PCB LAYOUT  
 TOLERANCE ± 0.05 (TOP VIEW)

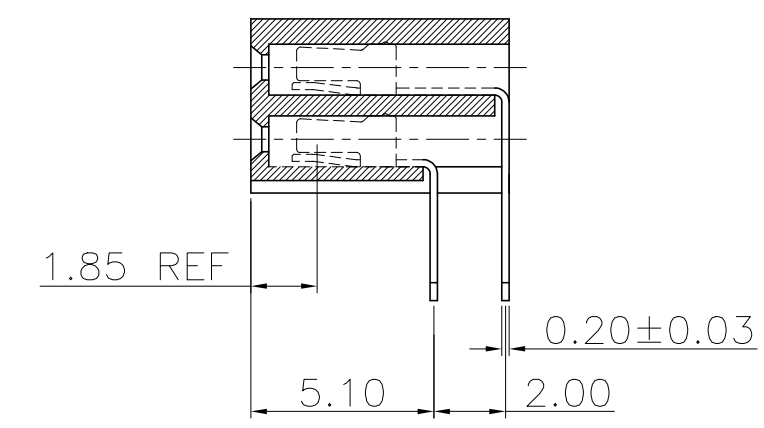
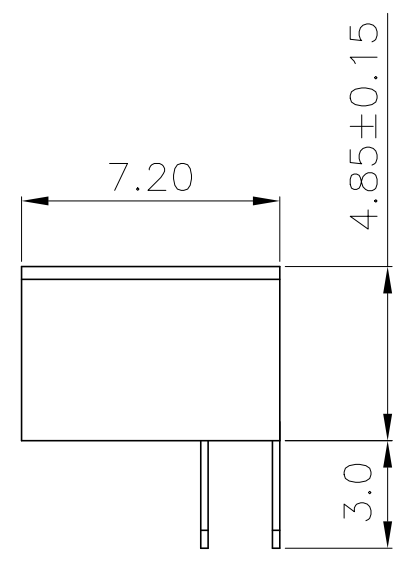
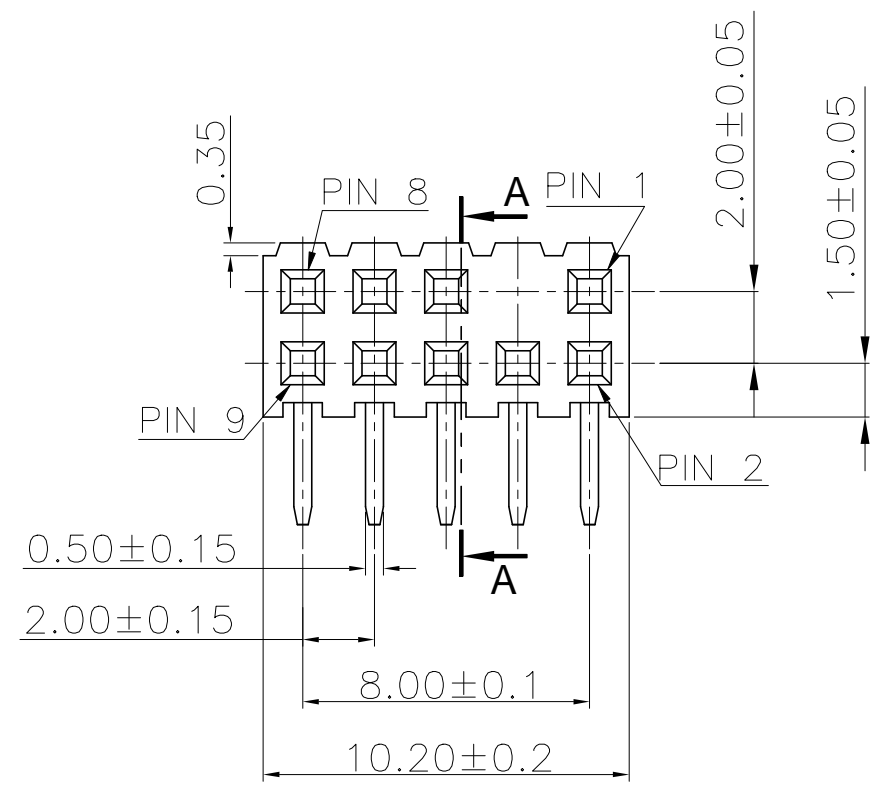

SECTION A-A

OBSOLETE	9	1734531-9
POSITION NUMBER		PART NUMBER

THIS DRAWING IS A CONTROLLED DOCUMENT.		DWN O.HU 05JUL2005	TE Connectivity Ltd.				
DIMENSIONS: mm		CHK S.HOU 05JUL2005					
TOLERANCES UNLESS OTHERWISE SPECIFIED:		APVD W.J.KE 05JUL2005	NAME AMPMODU 2.0mm PITCH, RCPT CONN., RIGHT-ANGLE, MOUNT TYPE				
0 PLC ± 0.5 1 PLC ± 0.2 2 PLC ± 0.1 3 PLC ± 0.05 4 PLC ± - ANGLES ± 3°		PRODUCT SPEC 108-57197	SIZE A3	CAGE CODE 00779	DRAWING NO 1734531	RESTRICTED TO -	
MATERIAL SEE SHEET 1	FINISH SEE SHEET 1	APPLICATION SPEC -	WEIGHT -	SCALE 1:1		SHEET 2 of 3	REV D5
CUSTOMER DRAWING							

4

3

2

1

THIS DRAWING IS UNPUBLISHED  
 RELEASED FOR PUBLICATION  
 ALL RIGHTS RESERVED.

REVISIONS				
P	LTR	DESCRIPTION	DATE	APVD
-	-	SEE SHEET 1	-	-

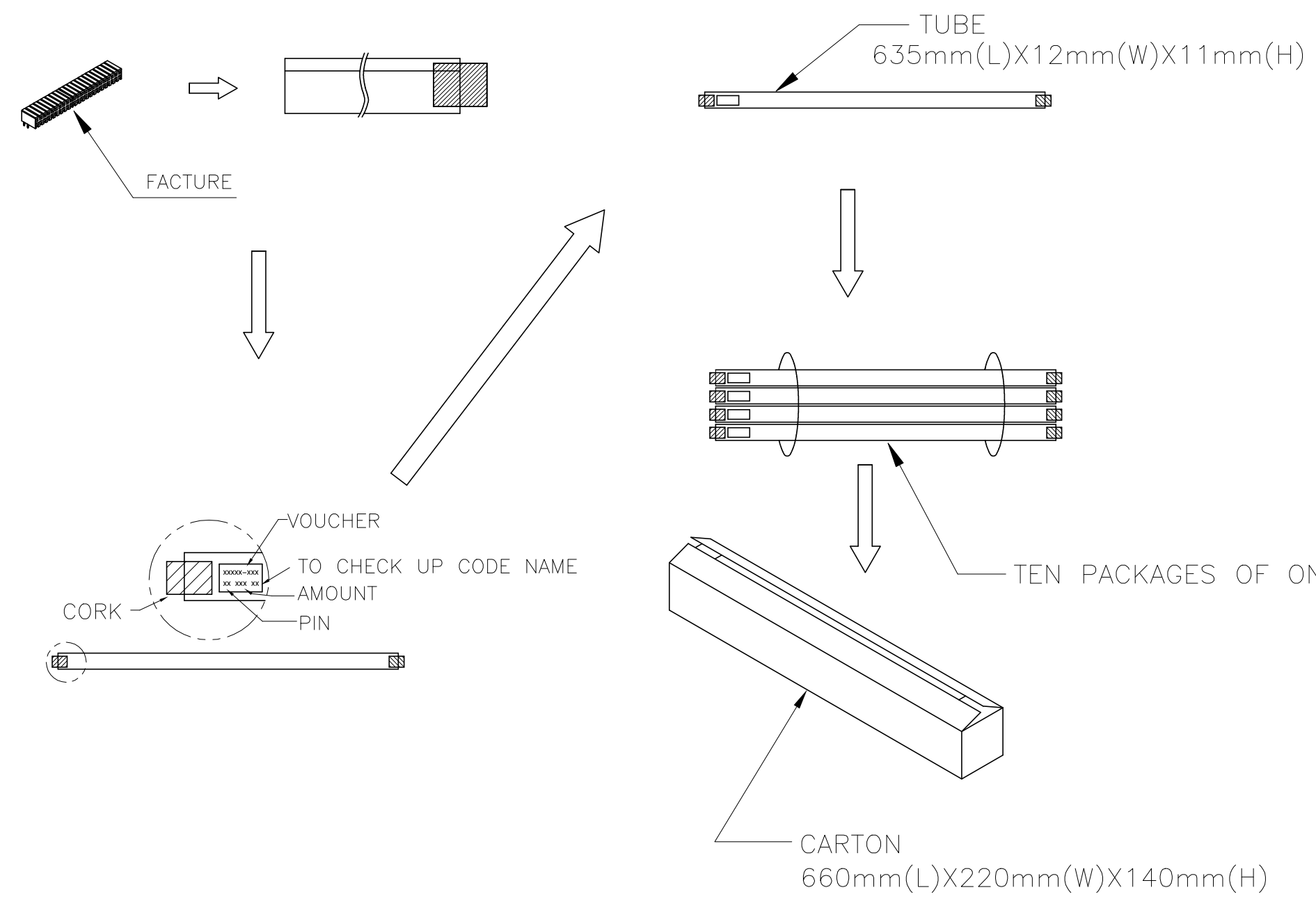

OBSOLETE	1050	150	7	80	8	-0
	1050	150	7	78	7	-8
	1050	150	7	76	7	-6
	1200	150	8	74	7	-4
	1200	150	8	72	7	-2
	1200	150	8	70	7	-0
	1200	150	8	68	6	-8
	1350	150	9	66	6	-6
	1350	150	9	64	6	-4
	1350	150	9	62	6	-2
	1500	150	10	60	6	-0
	1500	150	10	58	5	-8
	1500	150	10	56	5	-6
	1650	150	11	54	5	-4
OBSOLETE	1650	150	11	52	5	-2
	1800	150	12	50	5	-0
	1800	150	12	48	4	-8
	1950	150	13	46	4	-6
	1950	150	13	44	4	-4
	2100	150	14	42	4	-2
	2100	150	14	40	4	-0
	2250	150	15	38	3	-8
OBSOLETE	2400	150	16	36	3	-6
	2550	150	17	34	3	-4
	2700	150	18	32	3	-2
	2850	150	19	30	3	-0
	3150	150	21	28	2	-8
OBSOLETE	3300	150	22	26	2	-6
	3600	150	24	24	2	-4
	3900	150	26	22	2	-2
	4350	150	29	20	2	-0
	4800	150	32	18	1	-8
	5400	150	36	16	1	-6
	6150	150	41	14	1	-4
	7200	150	48	12	1	-2
	8550	150	57	10	1	-0
OBSOLETE	8550	150	57	9	-	1734531-9
OBSOLETE	10650	150	72	8	-	1734531-8
	14400	150	96	6	-	1734531-6
	21600	150	144	4	-	1734531-4
QTY	TUBE/ CARTON	PCS/ TUBE	POSITION NUMBER	PART NUMBER		

THIS DRAWING IS A CONTROLLED DOCUMENT.		DWN O.HU 05JUL2005	TE Connectivity Ltd.		
DIMENSIONS: mm		CHK S.HOU 05JUL2005			
TOLERANCES UNLESS OTHERWISE SPECIFIED:		APVD W.J.KE 05JUL2005	NAME AMPMODU 2.0mm PITCH, RCPT CONN., RIGHT-ANGLE, MOUNT TYPE		
0 PLC ± 0.5 1 PLC ± 0.2 2 PLC ± 0.1 3 PLC ± 0.05 4 PLC ± - ANGLES ± 3°		PRODUCT SPEC 108-57197	SIZE A3	CAGE CODE 00779	DRAWING NO 1734531
MATERIAL SEE SHEET 1		FINISH SEE SHEET 1	APPLICATION SPEC -	RESTRICTED TO -	
		WEIGHT -	CUSTOMER DRAWING		
			SCALE 1:1	SHEET 3 of 3	REV D5