

bq51025 Evaluation Module (PWR649)

The bq51025EVM-649 (PWR649) wireless power receiver evaluation kit (EVM) from TI is a high performance, easy-to-use development kit for the design of wireless power solutions. It helps designers evaluate the operation and performance of the bq51025 IC, a secondary-side receiver device for wireless power transfer applications. The bq51025 device is a fully-contained, wireless power receiver capable of operating in WPC v1.1 protocol which allows a wireless power system to deliver up to 5 W to the system when used with a Qi inductive transmitter. When paired with the bq500215EVM-648 (PWR648), the bq51025 is capable of delivering up to 10 W to the system. The bq51025 device provides a single device power conversion (rectification and regulation) as well as the digital control and communication for WPC specification. The kit enables designers to speed up the development of their end-applications.

Contents

1	Introduction	2
2	Considerations with this EVM	3
3	Modifications.....	4
4	Recommended Operating Conditions	4
5	Equipment and EVM Setup.....	5
	5.1 Schematic.....	5
	5.2 Recommended Test Equipment	6
	5.3 Equipment Setup.....	6
	5.4 Connector Descriptions	7
	5.5 Jumpers and Switches	7
	5.6 Test Point Descriptions	8
	5.7 Pin Description of the IC	9
6	Test Procedure	10
	6.1 Definition.....	10
	6.2 Procedure	10
7	Test Results.....	14
	7.1 Steady-State Operation with the bq24261 Charger	14
	7.2 Load Step	15
	7.3 Start Up.....	16
	7.4 Efficiency Data.....	17
	7.5 Adapter Insertion and Removal	17
	7.6 Thermal Performance.....	18
8	Layout and Bill of Material	19
	8.1 bq51025 Traces	19
	8.2 Layout Guidelines	19
	8.3 Printed-Circuit Board Layout Example	19
	8.4 bq51025EVM-649 Layout	21
	8.5 Bill of Materials (BOM).....	24

List of Figures

1	bq51025EVM-649 Schematic	5
2	Placement of PWR649 on PWR648	11
3	bq51025 in Steady State Operation with bq24261	14
4	1-A Load Step	15
5	1.4-A Load Step	15

6	Start Up With 1000 mA	16
7	Start Up With 1400 mA	16
8	System Efficiency Versus Output Power	17
9	Adapter Insertion and Removal	17
10	Thermal Image (1400-mA Load)	18
11	bq51025EVM-649 Layout Example	20
12	bq51025EVM-649 Top Assembly	21
13	bq51025EVM-649 Layer 1	21
14	bq51025EVM-649 Layer 2	22
15	bq51025EVM-649 Layer 3	22
16	bq51025EVM-649 Layer 4	23

List of Tables

1	bq51025EVM-649 Recommended Operating Conditions	4
2	Pin Description	9
3	bq51025EVM-649 Bill of Materials	24

1 Introduction

The bq51025 is an advanced, flexible, secondary-side device for wireless power transfer applications capable of sourcing up to 10 W. The bq51025 device integrates an ultra-low-impedance synchronous rectifier, a very-high-efficiency post regulator, digital control, and accurate voltage and current loops. The bq51025 devices provide the AC/DC power conversion while integrating the digital control required. The IC complies with the WPC v1.1 communication protocol.

Together with a bq500xxx primary-side controller transmitter (or any other WPC v1.1 transmitter), the bq51025 enables a complete contactless power transfer system for a 5-W wireless power supply solution. By utilizing near-field inductive power transfer, the secondary coil embedded in the mobile device can pick up the power transmitted by the primary coil. The voltage from the secondary coil is then rectified and regulated to be used as a power supply for down-system electronics. Global feedback is established from the secondary to the primary in order to control the power transfer process.

In WPC, system communication is digital (packets are transferred from the secondary to the primary). Differential bi-phase encoding is used for the packets. The bit rate is 2 kb/s. Various types of communication packets have been defined. These include identification and authentication packets, error packets, control packets, power usage packets and efficiency packets, among others.

When paired with the bq500215 primary-side controller transmitter, the bq51025 is capable of delivering up to 10 W. The bq51025 incorporates a proprietary two-way authentication with the bq500215 primary controller that allows optimal power transfer and system performance up to 10-W output power.

2 Considerations with this EVM

The bq51025EVM-649 evaluation module (PWR649) demonstrates the receiver portion of the wireless power system. This receiver EVM is a complete receiver-side solution that produces 10-W output power at up to 2-A load with adjustable output voltage. The 10-W output power can be delivered from various output voltages. The output current is limited so that the overall delivered power is less than 10 W. For example, a 10-V output can supply up to 1 A, whereas a 5-V output can deliver up to 2 A. The default configuration for this EVM is a 7-V output capable of delivering up to 1.43 A.

- The receiver can be used in any number of devices as a power supply for a battery charger. With contact-free charging capability, no connections to the charging power source are required.
- 5-W power delivery with any WPC v1.1 transmitter
- 10-W power delivery with the bq500215 transmitter
- Highly-integrated wireless power receiver solution
 - Ultra-efficient synchronous rectifier
 - Very high efficiency post regulator
 - WPC v1.1-compliant communication and control
 - Only one IC required between RX coil and DC output
- Programmable output voltage to optimize performance for application
- Adaptive communication current limit (CM_ILIM) for robust communication
- Supports 20-V max input
- Low-power dissipative overvoltage clamp
- Overvoltage, overcurrent, overtemperature protection
- Low-profile, external pick-up coil
- Frame is configured to provide correct receiver to transmitter spacing
- Room above coil for testing with battery, key for Foreign Object Detection (FOD) tuning
- Options to adjust the input current limit and output voltage using resistors or I²C
- Flexibility for FOD tuning
- Adjustable resistor that can be used to set RFOD
- Temperature sensing can be adjusted using external resistors
- Micro-USB connector for adapter testing configuration
- I²C connector (USB-TO-GPIO "HPA172" kit for I²C communication through computer is required)
- \overline{WPG} LED indicator (Green LED is on when V_{OUT} is high)
- $\overline{PD_DET}$ LED indicator (Orange LED is on when the RX is on TX pad)

3 Modifications

See the bq51025 data sheet ([SLUSBX7](#)) when changing components. To aid in such customization of the EVM, the board was designed with devices having 0402 and 0603 or larger footprints. A real implementation likely occupies less total board space.

Note that changing components can improve or degrade EVM performance. Special attention should be given to the resonant capacitors (C1, C2, and C3). Thermal performance of these capacitors can greatly impact overall system performance.

4 Recommended Operating Conditions

[Table 1](#) provides a summary of the bq51025EVM-649 performance specifications. All specifications are given for an ambient temperature of 25°C.

Table 1. bq51025EVM-649 Recommended Operating Conditions

PARAMETER		TEST CONDITION	MIN	TYP	MAX	UNIT
V _{RECT}	RECT voltage range		4		11	V
I _{OUT}	Output current	Current limit programming range			2	A
I _{AD_EN}	Sink current				1	mA
V _{OUT(REG)}	Programmable output voltage ⁽¹⁾	P _{OUT} = 10 W with the bq500215 transmitter EVM (PWR648), otherwise P _{OUT} = 5 W	4.5	7	10	V
f _s	Switching frequency		110		205	kHz
T _J	Junction temperature		0		125	°C

⁽¹⁾ The output voltage can be adjusted using I²C or the VIREG and VO_REG resistors. Also the coil needs to change for different output voltage levels for optimal operation of the EVM. See the bq51025 datasheet for details.

5 Equipment and EVM Setup

5.1 Schematic

Figure 1 shows the PWR649 schematic with the bq51025 output set to 7 V.

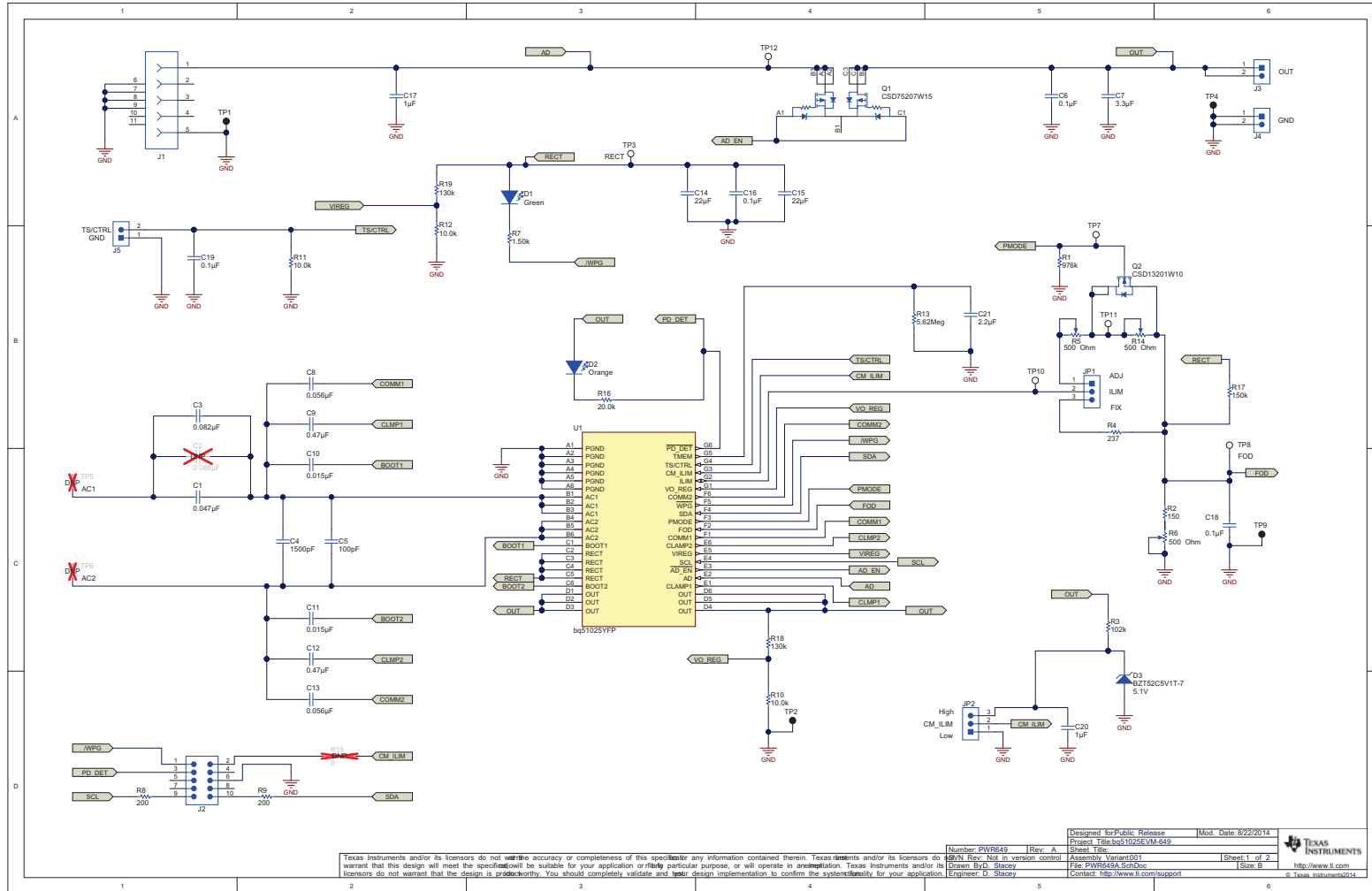

Figure 1. bq51025EVM-649 Schematic

5.2 Recommended Test Equipment

The following equipment is needed to complete this test procedure:

Power Supplies

- Power supply #1 (PS #1) capable of supplying 12 V at 2 A is required (for bq500215EVM-648 10-W transmitter)
- Power supply #2 (PS #2) capable of supplying 5 V at 2 A is required (for bq500212AEVM-550 5-W transmitter)
- Power supply #3 (PS #3) capable of supplying 5 V at 1 A is required (for adapter testing)

Loads

- For simplicity, resistive loads should be used that can be set to 5 Ω /1400 mA, 14 Ω /500 mA, and 7 k Ω /1 mA. The power rating should be 10 W. An electronic load will work as well, but the discussion focuses on the resistive load setup.
- The default setting for this EVM is for a 7-V output. Changing this value will require additional changes to the EVM including a different coil. Details can be found in the bq51025 datasheet.

Meters

- Three DC voltmeters, two DC ammeters and one ohmmeter

Oscilloscopes

- Not required but can be used to view traces as needed

bqTesla Transmitters

- The PWR648 transmitter (bq500215EVM-648) is required for 10-W testing and requires a 12-V input supply (PS #1)
- The PWR550 transmitter (bq500212AEVM-550) is recommended for 5-W testing and requires a 5-V input supply (PS #2). Any other WPC v1.1 transmitter can be substituted (care must be given to the required input power supply).

Recommended Wire Gauge

- For proper operation, TI recommends 22-AWG wire or larger

5.3 Equipment Setup

The following items ensure proper equipment setup:

Test Set Up

- Set power supplies to OFF
- 10-W testing will be done with the PWR648 transmitter. Input voltage to the PWR648 is set with PS #1 to 12 VDC \pm 200 mV, with a current limit of 2.0 A.
- Connect PS #1 positive terminal to J1 and negative terminal to J2 of PWR648
- 5-W testing will be done with the PWR550 transmitter. Input voltage to the PWR550 is set with PS #2 to 5 VDC \pm 200 mV, with a current limit of 2.0 A.
- Connect PS #2 positive terminal to J1 and negative terminal to J2 of PWR550

Load

- The load is connected between J3-OUT and J4-GND of PWR649
- A DC ammeter is connected between PWR649 and load

Jumper Settings

- JP1 \rightarrow ILIM and FIX are shorted
- JP2 \rightarrow CM_ILM and High are shorted

Voltage and Current Meters

- Connect the ammeter to measure PS #1 (12-V input) current to the PWR648. Connect the voltmeter to monitor the input voltage at J1 and J2 of PWR648 unit.

- A voltmeter is used on the PWR649 to measure output voltage at J3 with ground at J4. Connect the ammeter to measure load current.
- When 5-W testing is to be done, connect the ammeter to measure PS #2 (5-V input) current to the PWR550. Connect the voltmeter to monitor the input voltage at J1 and J2 of PW550 unit.

RFOD: R6 Set Up

- Connect the ohmmeter between TP8 (FOD) and TP9 (GND). Verify $R2 + R6$ is approximately 256 Ω ; adjust, if necessary.

5.4 Connector Descriptions

The connections points are described in the following paragraphs.

5.4.1 J1 – AD External Adapter Input

Power can be provided to simulate an external adapter applied to the receiver in this bq51025EVM-649 (PWR649).

5.4.2 J2 – Programming Connector

This connector is populated and can be used for I²C communication using the USB-TO-GPIO "HPA172" kit.

5.4.3 J3 – Output Voltage

Output voltage in wireless power mode up to 2 A (default configuration limits to 1.4 A at 7 V); the adapter option is also supported in this PWR649.

5.4.4 J4 –GND

Ground return

5.4.5 J5 – TS/CTRL and Return Connector

External connection for temperature sense resistor, see data sheet for additional information.

5.5 Jumpers and Switches

The control jumpers are described in the following paragraphs.

5.5.1 JP1– ILIM (FIX or ADJ)

Maximum output current is set by the ILIM pin. In the FIX position, the current is set to a fixed value of R4 plus RFOD ($R2 + R6$ as set by the factory) (approximately 1.4 A). In the ADJ position, current is set by R5 and R14 along with RFOD.

5.5.2 JP2 – CM_ILIM

Enables CM_ILIM feature when pulled low and disables when pulled high. Default position is high (disabled).

5.6 Test Point Descriptions

The test points are described in the following paragraphs:

5.6.1 TP1, TP2, TP4, and TP9 – Ground

These test points are used for ground connections.

5.6.2 TP3– Rectified Voltage

The input AC voltage is rectified into unregulated DC voltage (V_{RECT}); additional capacitance is used to filter the voltage before the regulator.

5.6.3 TP5 and TP6 – AC1 and AC2 Inputs

Test points are not populated, they can be used for measuring AC voltage applied to the EVM from the receiver coil. These points are used for connecting the receiver's coil.

5.6.4 TP7– PMODE

Indicator of power mode, low if in 10-W mode, high if in 5-W mode. Pin F3 of the bq51025.

5.6.5 TP8 – FOD

Input for rectified power measurement for FOD feature in WPC, pin F2 of the IC. TP8 is the FOD pin of the bq51025.

5.6.6 TP10– ILIM

Programming pin for overcurrent limit protection, pin G2 of the bq51025.

5.6.7 TP11– 10-W ILIM

Allows individual trimming of R5 and R14 for optimum power delivery for 5-W and 10-W systems.

5.6.8 TP12– Input Power

Connected to J1 pin 1. Alternative connection for wired power.

5.7 Pin Description of the IC

Table 2 contains the pin descriptions.

Table 2. Pin Description

PIN Number (WCSP)	bq51025
A1, A2, A3, A4, A5, A6	PGND
B1, B2, B3	AC1
B4, B5, B6	AC2
C1	BOOT1
C2, C3, C4, C5	RECT
C6	BOOT2
D1, D2, D3, D4, D5, D6	OUT
E1	CLAMP1
E2	AD
E3	AD_EN
E4	SCL
E5	VIREG
E6	CLAMP2
F1	COMM1
F2	FOD
F3	PMODE
F4	SDA
F5	WPG
F6	COMM2
G1	VO_REG
G2	ILIM
G3	CM_ILIM
G4	TS/CTRL
G5	TMEM
G6	PD_DET

6 Test Procedure

This procedure describes the test configuration of the bq51025EVM-649 evaluation board (PWR649) for bench evaluation.

6.1 Definition

The following naming conventions are used:

VXXX :	External voltage supply name (VBAT, VTS, V_{OUT})
LOADW:	External load name (LOADR, LOADI)
V(TPyy):	Voltage at internal test point TPyy. For example, V(TP02) means the voltage at TP02.
V(Jxx):	Voltage at header Jxx
V(TP(XXX)):	Voltage at test point XXX. For example, V(TP(ACDET)) means the voltage at the test point which is marked as ACDET.
V(XXX, YYY):	Voltage across point XXX and YYY
I(JXX(YYY)):	Current going out from the YYY terminal of header XX
Jxx(BBB):	Terminal or pin BBB of header xx
JPx ON :	Internal jumper Jxx terminals are shorted
JPx OFF:	Internal jumper Jxx terminals are open
JPx (-YY-) ON:	Internal jumper Jxx adjacent terminals marked as YY are shorted
UUT:	Unit Under Test (PWR649 EVM)

Assembly drawings have locations for jumpers, test points, and individual components.

6.2 Procedure

The following operating procedures are provided at a variety of operating loads. Initial testing is done with the 10-W transmitter (PWR648).

[Figure 2](#) shows the proper alignment between the transmitter (PWR648) and receiver (PWR649).

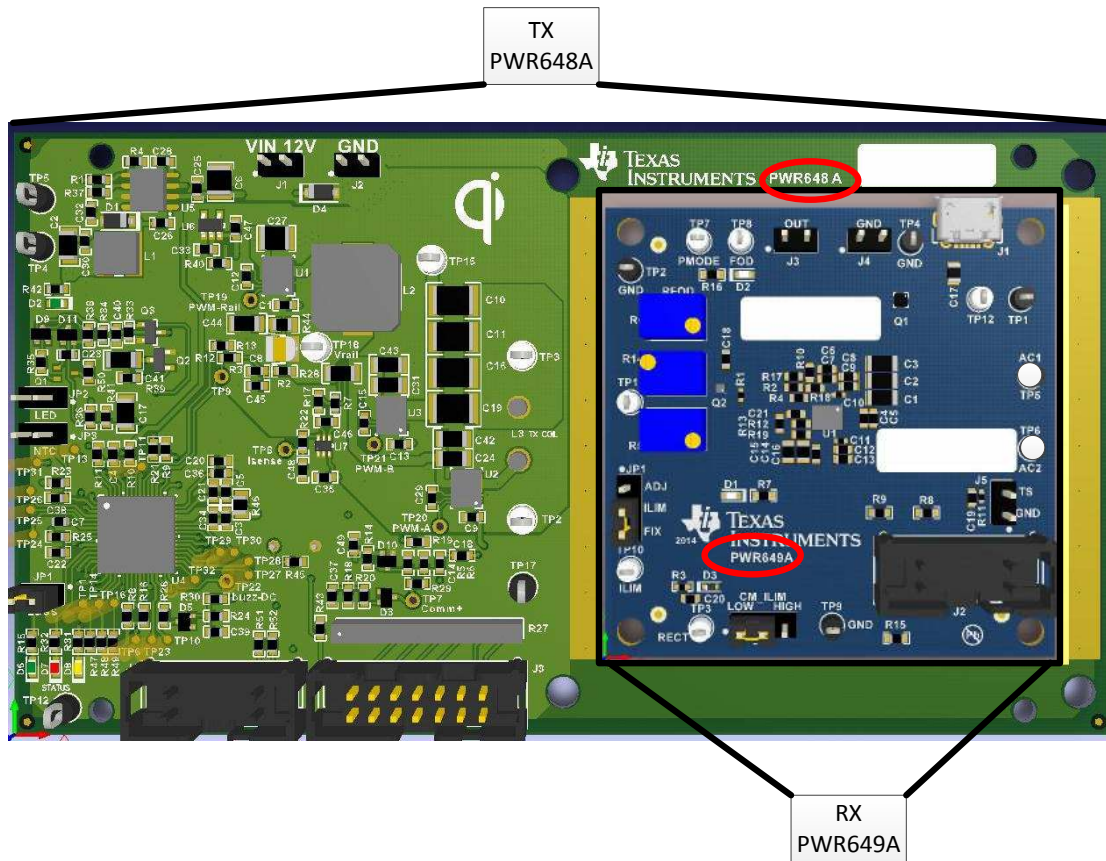

Figure 2. Placement of PWR649 on PWR648

Turn ON Operation and Operation at 1400-mA Load (approximately 10 W)

- Turn ON transmitter power supply PS #1 (12 V)
- Wait approximately 1 second for the transmitter to start
- Transmitter – Verify LED D2 is blinking and D6 is OFF
- UUT – Adjust load current to 1400 mA ±50 mA
- Place the UUT on center of the PWR648 TX coil
- After about 1 second, verify that:
 - The transmitter should beep
 - Transmitter – LED D2 (green) is ON and LED D6 (green) is blinking (about 2 times per second)
 - Receiver – LED D1 (green) is ON and LED D2 (orange) is ON
 - UUT – Verify that V_{OUT} is 6.9 V to 7.2 V (between J3 and J4)
 - UUT – Verify that the voltage between TP7 and TP2 (ground) measures less than 0.1 V (verifies 10-W mode)
 - UUT – Verify that the rectified voltage is 7 V to 7.4 V (between TP3 and TP4) **NOTE:** a modulation signal is present on this voltage every 250 ms and may cause fluctuation in the reading: use the baseline value.

Efficiency Test (1400-mA Load)

- Verify that PS #1 input current is less than 1200 mA
- Note that if the CM_ILIM jumper (JP2) is set to low, the efficiency will be negatively impacted
- Remove UUT from the TX and turn OFF PS #1

Turn ON Operation and Operation at 500-mA Load (approximately 3.5 W)

- Turn ON PS #1
- Wait approximately 1 second for transmitter to start
- Transmitter – Verify LED D2 is blinking and LED D6 is OFF
- UUT – Adjust load current to 500 mA \pm 50 mA
- Place the UUT on center of the PWR648 TX coil
- After about 1 second, verify that:
 - The transmitter should beep
 - Transmitter – LED D2 (green) is ON and LED D6 (green) is blinking (about 2 times per second)
 - Receiver – LED D1 (green) is ON and LED D2 (orange) is ON
 - UUT – Verify that V_{OUT} is 6.9 V to 7.2 V (between J3 and J4)
 - UUT – Verify that the rectified voltage is 7.0 V to 7.4 V (between TP3 and TP9) **NOTE:** a modulation signal is present on this voltage every 250 ms and may cause fluctuation in the reading: use the baseline value.

Efficiency Test (500-mA Load)

- Verify that PS #1 input current is less than 425 mA
- Remove UUT from the TX and turn OFF PS #1

Operation (1-mA Load)

- Turn ON PS #1
- Wait approximately 1 second for transmitter to start
- Transmitter – Verify LED D2 is blinking and LED D6 is OFF
- UUT – Adjust load current to 1 mA \pm 200 μ A
- Place the UUT on center of the PWR648 TX coil
- After about 1 second, verify that:
 - The transmitter should beep
 - Transmitter – LED D2 (green) is ON and LED D6 (green) is blinking (about 2 times per second)
 - Receiver – LED D1 (green) is ON and LED D2 (orange) is ON
 - UUT – Verify that V_{OUT} is 6.9 V to 7.2 V (between J3 and J4)
 - UUT – Verify that the rectified voltage is 8.0 V to 10.0 V (between TP3 and TP9) **NOTE:** a modulation signal is present on this voltage every 250 ms and may cause fluctuation in the reading: use the baseline value.

Efficiency Test (1-mA Load)

- Verify that PS #1 input current is less than 110 mA
- Remove UUT from the TX and turn OFF PS #1

Adapter Test (500-mA Load)

- Initial adapter testing will be done without the transmitter
- Connect 5 V \pm 250 mV adapter on J1 on the bq51025EVM-649 receiver (or use TP12 / PS #3 and GND)
- Adjust the load current to 500 mA \pm 50 mA (J3 OUT and J4 GND)
- Verify that:
 1. UUT – LED D1 is OFF and LED D2 is OFF
 2. UUT – V_{OUT} is 5.0 V \pm 600 mV (J3 to J4)
- Turn ON PS #1
- Wait approximately 1 second for transmitter to start
- Transmitter – LED D2 is blinking and LED D6 is OFF
- Place the UUT on center of the PWR648 TX coil while the adapter is still connected to J1 (or TP12)

- After 1 second verify that:
 - The transmitter should NOT beep
 - Transmitter – LED D2 is ON and LED D6 is OFF
 - Receiver – LED D1 is OFF and LED D2 is ON
 - UUT – Verify that V_{OUT} is 4.9 V to 5.2 V (between J3 and J4)
 - This shows that wireless power is disabled
- Keep the UUT on the transmitter and remove the power on J1 (or TP12) of the UUT
- After approximately 1 second verify that:
 - The transmitter should beep
 - Transmitter – LED D2 is ON and LED D6 is blinking
 - Receiver – LED D1 is ON and LED D2 is ON
 - UUT – Verify that V_{OUT} is 6.8 V to 7.2 V (between J3 and J4)
 - This shows that wireless power is enabled
- Remove UUT from the TX and turn OFF PS #1

5-W Transmitter Test (500-mA Load)

- The UUT will be tested with the 2nd transmitter - PWR550
- The PWR550 EVM requires a 5-V supply with a 2.0-A current limit (PS #2)
- **NOTE:** Any other 5-W transmitter can be substituted, but the discussion from the transmitter side is only relevant to the PWR550 EVM
- Connect 5 V \pm 100 mV adapter on J1 on the PWR550 transmitter
- Place the UUT in the center of the PWR550 TX coil
- Adjust the load current to 500 mA \pm 50 mA (J3 *OUT* and J4 *GND*)
- Turn ON PS #2
- After approximately 1 second, verify that:
 1. PWR550 – LED D1 (blue) is ON, LED D5 (green) is blinking about once per second
 2. UUT – LED D1 is ON and LED D2 is ON
 3. UUT – V_{OUT} is 6.9 V to 7.2 V (J3 to J4) (approximately 3.5 W)
 4. UUT – TP7 to TP2 (ground) measures above 1.5 V (this verifies that the receiver is in 5-W mode)
- Verify the maximum power is limited with the 5-W transmitter
 1. Slowly increase load current towards 900 mA (towards 6 W)
 2. Before 900 mA is reached, V_{OUT} of the PWR649 will begin to decrease towards 6.0 V (J3 to J4) indicating maximum power is reached
- Remove UUT from the TX and turn OFF PS #2

7 Test Results

7.1 Steady-State Operation with the bq24261 Charger

With the power supply off, connect the supply to the bqTESLA transmitter.

- Set up the test bench as described in [Section 6](#)
- Power the TX (PWR648) with 12 V
- Connect the output of the RX (PWR649) to battery charger bq24261EVM-079
- Using a source meter, set the VBAT to 3.5 V and the current limit to 3.5 A
- Using the bq24261 GUI, set the charger current to 2.1 A and the current limit to 2.5 A
- Monitor the I_{OUT} and V_{OUT} from the RX after putting the receiver EVM (PWR649) on the transmitter coil and aligning them correctly
- Monitor the I_{OUT} and V_{OUT} from the bq24261
- [Figure 3](#) shows the V_{OUT} and I_{OUT} from both the RX and the bq24261EVM-079. The output power from the bq51025 is approximately 10 W while the output power from the bq24261 is approximately 8.4 W.

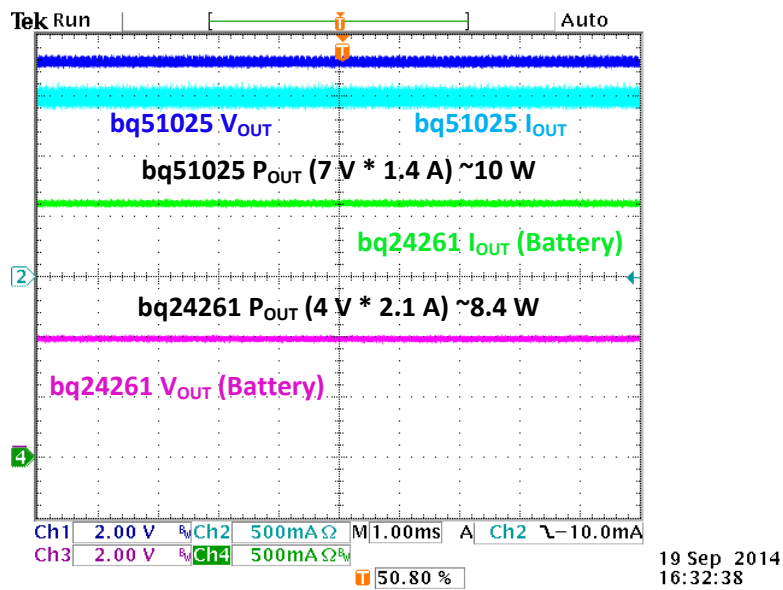
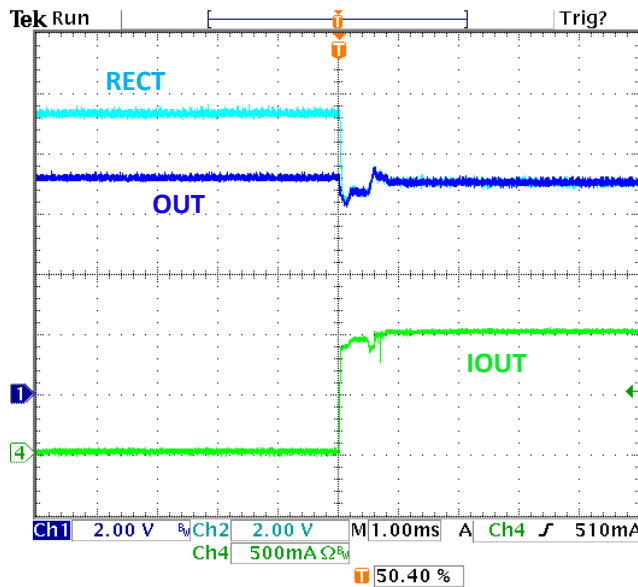

Figure 3. bq51025 in Steady State Operation with bq24261

7.2 Load Step

The procedure for load step is as follows:

- Set up the test bench as described in [Section 6](#)
- Power the TX (PWR648) with 12 V
- Provide a load step from no-load (high impedance) to 1000 mA by attaching a 7-Ω resistive load between J3 and J4 of the PWR649 EVM
- Monitor the RX signals: load current (I_{OUT}), rectifier voltage (RECT), and output voltage (OUT) as shown in [Figure 4](#)
- A 1.4-A load step is shown in [Figure 5](#). Note that this step requires more time to recover to the full output voltage.



17 Sep 2014
17:18:59

Figure 4. 1-A Load Step

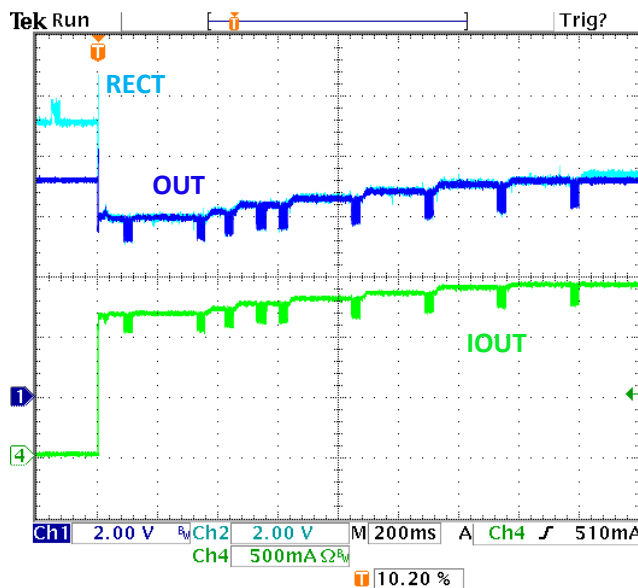

17 Sep 2014
17:22:11

Figure 5. 1.4-A Load Step

7.3 Start Up

The procedure for start-up test with load:

- Set up the test bench as described in [Section 6](#)
- Power the TX (PWR648) with 12 V
- Apply 7 Ω across J3 and J4 on PWR649 to generate a 1-A load
- Put the RX (PWR649) on the transmitter coil, and align them correctly
- Monitor the RECT pin, I_{OUT} , and output voltage (OUT), as shown in [Figure 6](#)
- Starting up with a 5 Ω at J3 to J4 generates a 1.4-A load and is shown in [Figure 7](#)

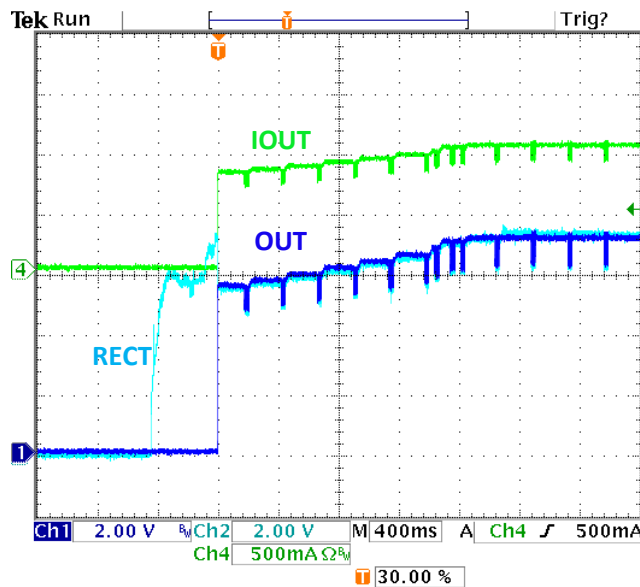

17 Sep 2014
16:38:17

Figure 6. Start Up With 1000 mA

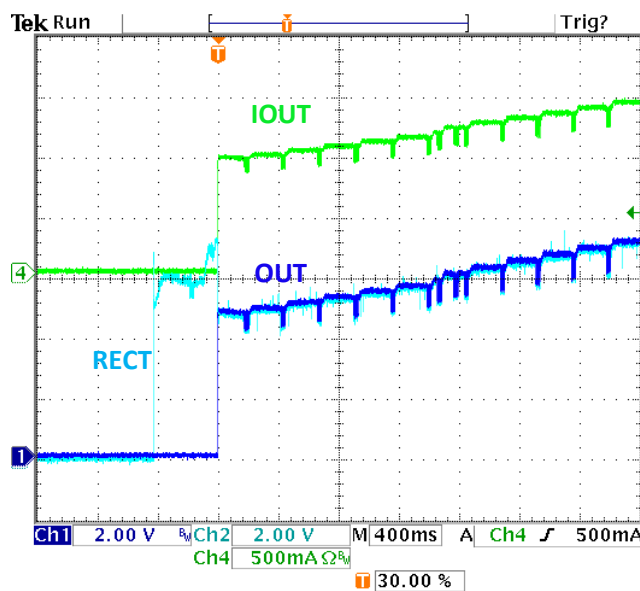

17 Sep 2014
16:36:46

Figure 7. Start Up With 1400 mA

7.4 Efficiency Data

Figure 8 illustrates the system (DC-DC) efficiency of the bq51025EVM-649 using the bq500212AEVM-550 5-W transmitter and the bq500215EVM-648 10-W transmitter.

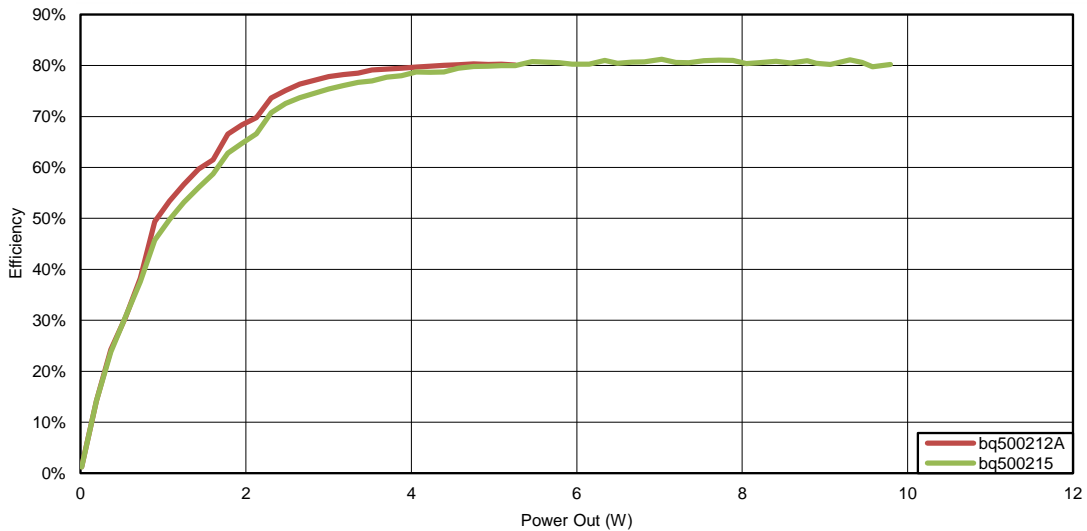

Figure 8. System Efficiency Versus Output Power

7.5 Adapter Insertion and Removal

Figure 9 illustrates the behavior of the bq51025EVM-649 when an adapter is inserted into J1 (or at TP12) while the EVM is on the transmitter pad with a resistive load at J3 to J4. There is some off time during the transitions between wireless power and wired power modes.

This illustration starts with no adapter. I_{OUT} is approximately 500 mA with V_{OUT} at 7 V. At 1.2 seconds of the plot, adapter power is added. The output changes from the 7-V wireless output voltage to the 5-V adapter voltage. With the resistive load, the output current drops proportionately. At about 2.3 seconds the adapter is removed. The restart time for wireless power is about 1 second.

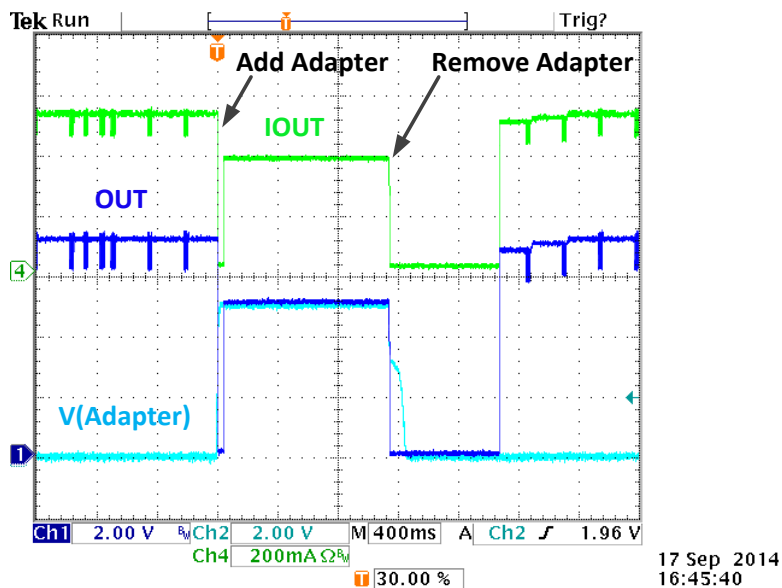

Figure 9. Adapter Insertion and Removal

7.6 Thermal Performance

This section shows a thermal image of the bq51025EVM-649. A 1.4-A load is used and the output voltage is set to 7 V (approximately 10 W). There is no air flow and the ambient temperature is 25°C. The peak temperature of the device (41.4°C) is well below the maximum recommended operating condition listed in the data sheet.

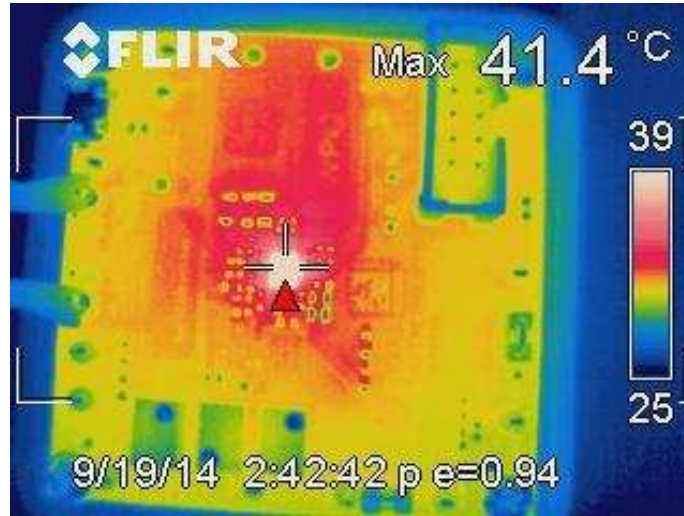

Figure 10. Thermal Image (1400-mA Load)

8 Layout and Bill of Material

8.1 bq51025 Traces

The bq51025 device pins can be classified as follows:

- **Signal/Sensing Traces**
 - TS/CTRL, PD_DET, WPG, COMM1, COMM2, ILIM, AD, AD_EN, FOD, TMEM, CM_ILIM, VO_REG, VIREG, PMODE, SCL, and SDA
 - Make sure these traces are isolated from the noisy traces
- **Noisy Traces**
 - AC1, AC2, BOOT1, BOOT2, COMM1, and COMM2
 - Make sure these traces are isolated from other traces, use ground plane
- **Power Traces**
 - AC1, AC2, OUT, CLAMP1, CLAMP2, and PGND
 - Make sure to use the correct width for the right current rating

8.2 Layout Guidelines

Use the following layout guidelines:

- The traces from the input connector to the inputs of the bq51025 device pin should be as wide as possible to minimize the impedance in the lines. Otherwise, this may cause the voltage to drop and could cause thermal issues.
- Keep the trace resistance as low as possible on AC1, AC2, OUT, and PGND
- Use the appropriate current rating traces (width) on AC1, AC2, OUT, and PGND
- The PCB should have a ground plane (return) connected directly to the return of all components through vias (At least two vias per capacitor for power-stage capacitors, one via per capacitor for small-signal components).
- Dissipation of heat is very important. The layout must allow for transfer of heat from high power items. Adding internal layers increases the thermal performance. Multiple vias in the PGND pins of the IC is recommended to decrease the thermal resistance in the board and allow much easier thermal dissipation through inner layer and power ground layers.
- The via interconnect is important and must be optimized near the power pad of the device and ground
- 2-oz copper, or greater, is recommended
- For high-current applications, the balls for the power traces should be connected to as much copper in the board as possible. This allows better thermal performance because the board conducts heat away from the device.
- It is always good practice to place high frequency bypass capacitors next to RECT and OUT

8.3 Printed-Circuit Board Layout Example

The primary concerns when laying a custom receiver PCB are as follows:

- AC1 and AC2, GND return trace resistance
- OUT trace resistance
- GND connection
- Copper weight ≥ 2 oz

For a 1.4-A fast charge current application, the current rating for each net is as follows:

- AC1 = AC2 = 2.2 A
- BOOT1 = BOOT2 = 1 A
- RECT = 200 mA (RMS)
- OUT = 2.5 A
- COMM1 = COMM2 = 600 mA
- CLAMP1 = CLAMP2 = 1000 mA
- ILIM = 10 mA
- AD = $\overline{\text{AD_EN}}$ = TS/CTRL = FOD = 1 mA

TI also recommends having the following capacitance on RECT and OUT:

- RECT $\geq 22 \mu\text{F}$
- OUT $\geq 1 \mu\text{F}$

It is always good practice to place high-frequency bypass capacitors next to RECT and OUT of 0.1 μF . Figure 11 illustrates an example of a WCSP layout.

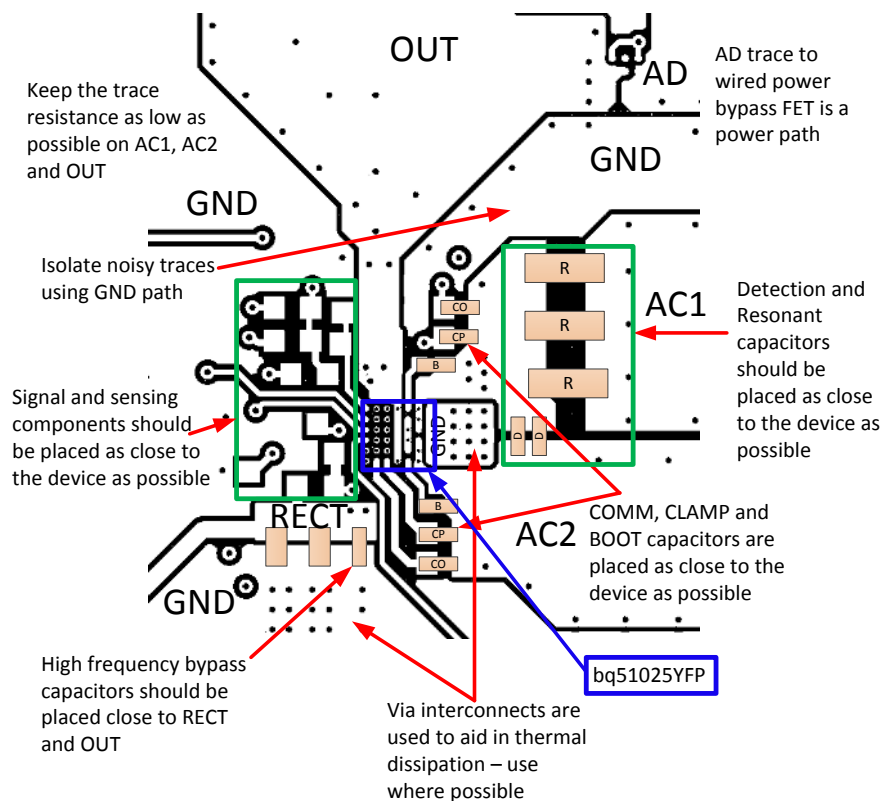

Figure 11. bq51025EVM-649 Layout Example

8.4 bq51025EVM-649 Layout

Figure 12 through Figure 16 show the bq51025EVM-649 PCB layout.

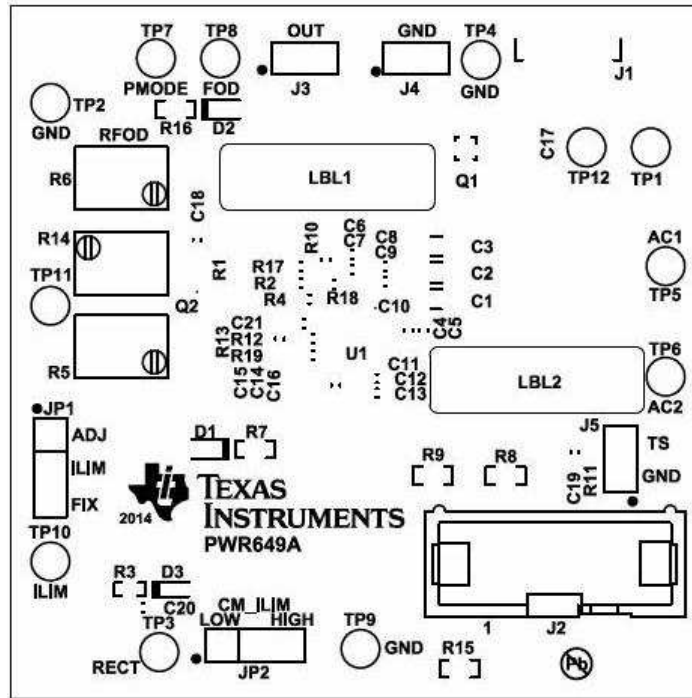

Figure 12. bq51025EVM-649 Top Assembly

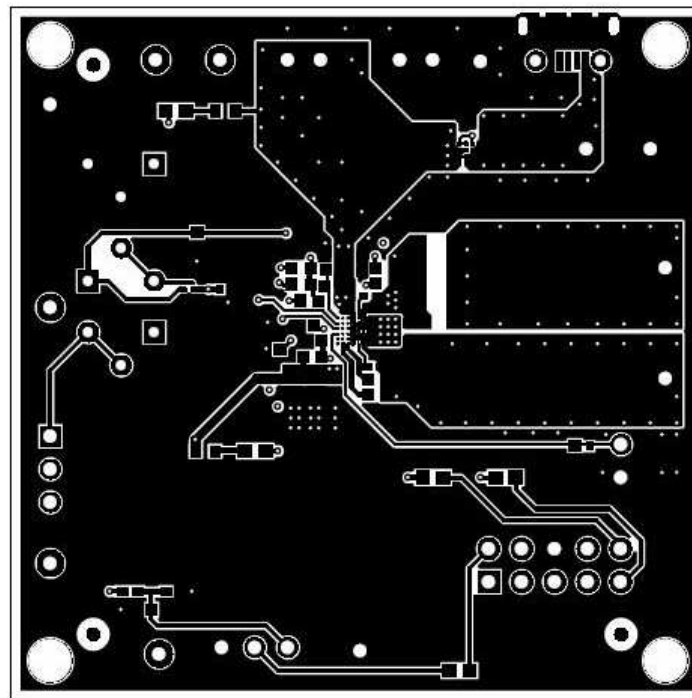

Figure 13. bq51025EVM-649 Layer 1

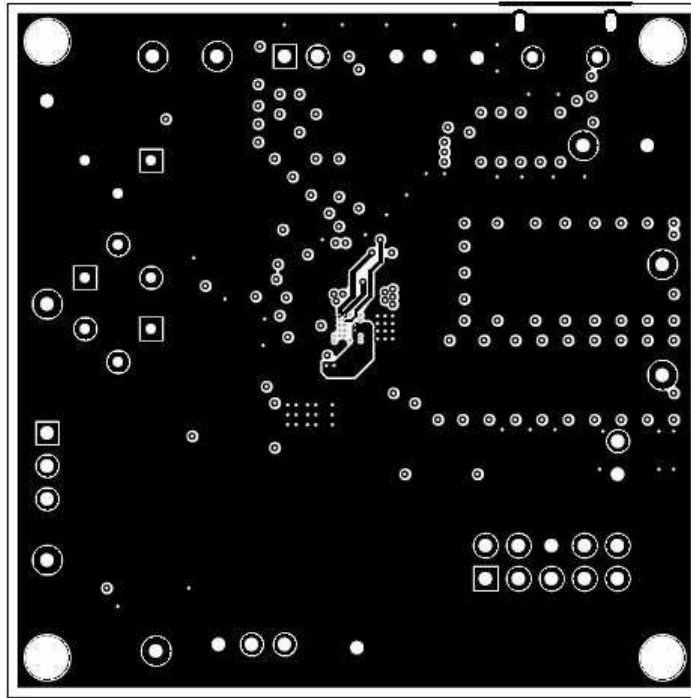

Figure 14. bq51025EVM-649 Layer 2

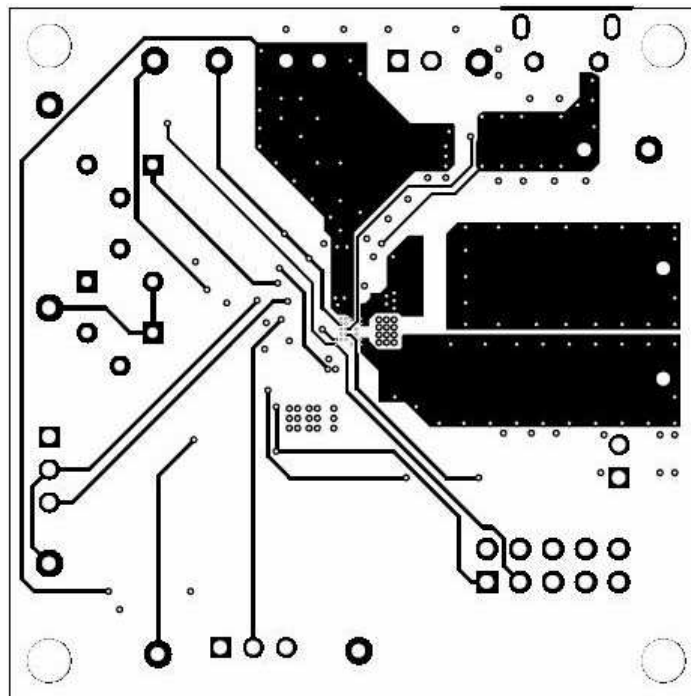

Figure 15. bq51025EVM-649 Layer 3

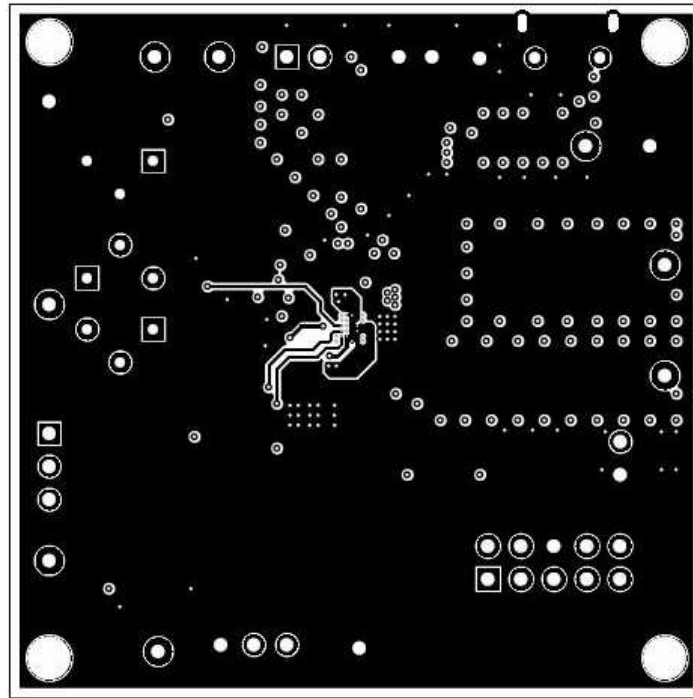

Figure 16. bq51025EVM-649 Layer 4

8.5 Bill of Materials (BOM)

Table 3 lists the BOM for the EVM.

Table 3. bq51025EVM-649 Bill of Materials

Designator	Quantity	Value	Description	PackageReference	PartNumber	Manufacturer
!PCB	1		Printed Circuit Board		PWR649	Any
C1	1	0.047uF	CAP, CERM, 0.047uF, 50V, +/-5%, C0G/NP0, 1206	1206	GRM31M5C1H473JA01L	MuRata
C3	1	0.082uF	CAP, CERM, 0.082uF, 50V, +/-5%, C0G/NP0, 1206	1206	GRM31C5C1H823JA01L	MuRata
C4	1	1500pF	CAP, CERM, 1500pF, 50V, +/-10%, X7R, 0603	0603	GRM188R71H152KA01D	MuRata
C5	1	100pF	CAP, CERM, 100pF, 50V, +/-5%, C0G/NP0, 0603	0603	GRM1885C1H101JA01D	MuRata
C6, C16, C18, C19	4	0.1uF	CAP, CERM, 0.1uF, 50V, +/-10%, X7R, 0603	0603	GCM188R71H104KA57B	MuRata
C7	1	3.3uF	CAP, CERM, 3.3uF, 25V, +/-10%, X5R, 0603	0603	C1608X5R1E335K080AC	TDK
C8, C13	2	0.056uF	CAP, CERM, 0.056uF, 25V, +/-10%, X7R, 0603	0603	GRM188R71E563KA01D	MuRata
C9, C12	2	0.47uF	CAP, CERM, 0.47uF, 25V, +/-10%, X5R, 0603	0603	GRM188R61E474KA12D	MuRata
C10, C11	2	0.015uF	CAP, CERM, 0.015uF, 50V, +/-10%, X7R, 0402	0402	GRM155R71H153KA12D	MuRata
C14, C15	2	22uF	CAP, CERM, 22uF, 25V, +/-20%, X5R, 0805	0805	GRM21BR61E226ME44	MuRata
C17	1	1uF	CAP, CERM, 1uF, 50V, +/-10%, X7R, 0805	0805	GRM21BR71H105KA12L	MuRata
C20	1	1uF	CAP, CERM, 1uF, 25V, +/-10%, X7R, 0603	0603	GRM188R71E105KA12D	MuRata
C21	1	2.2uF	CAP, CERM, 2.2uF, 16V, +/-10%, X5R, 0603	0603	GRM188R61C225KE15D	MuRata
D1	1	Green	LED, Green, SMD	1.6x0.8x0.8mm	LTST-C190GKT	Lite-On
D2	1	Orange	LED, Orange, SMD	1.6x0.8x0.8mm	LTST-C190KFKT	Lite-On
D3	1	5.1V	Diode, Zener, 5.1V, 300mW, SOD-523	SOD-523	BZT52C5V1T-7	Diodes Inc.
H1	1		Tape segment, Low Static Polyimide Film. Cut tape section from 36 yard roll	1.5" x 2.3"	5419-1 1/2"	3M
H2	1		Case Modified Polycase LP-11B with 4 screws		J-6838A	Polycase
H3	1		Coil, RX with Attractor		IWAS4832FEEB150J50	Vishay
H4, H5, H6, H7	4		#4 x 3/8" pan head phillips screw	#4 x 3/8"	PMSSS 440 0038 PH	B&F Fastener
H8, H9, H10, H11	4		Spacer, 0.100" Thk x 0.25" OD x 0.147" ID	0.1" THK	905-100	Bivar
J1	1		Receptacle, Micro-USB-B, Right Angle, SMD	Micro USB receptacle	105017-0001	Molex
J2	1		Connector, 100mil Shrouded, High-Temperature, Gold, TH	5x2 Shrouded header	N2510-6002-RB	3M
J3, J4, J5	3		Header, 100mil, 2x1, Tin plated, TH	Header, 2 PIN, 100mil, Tin	PEC02SAAN	Sullins Connector Solutions
JP1, JP2	2		Header, 100mil, 3x1, Tin plated, TH	Header, 3 PIN, 100mil, Tin	PEC03SAAN	Sullins Connector Solutions
LBL1, LBL2	2		Thermal Transfer Printable Labels, 0.650" W x 0.200" H - 10,000 per roll	PCB Label 0.650"H x 0.200"W	THT-14-423-10	Brady
Q1	1	-20V	MOSFET, P-CH, -20V, -3.9A, 1.5mm sq WCSP	1.5mm sq WCSP	CSD75207W15	Texas Instruments
Q2	1	12V	MOSFET, N-CH, 12V, 1.6A, 1x0.62x1mm	1x0.62x1mm	CSD13201W10	Texas Instruments
R1	1	976k	RES, 976k ohm, 1%, 0.063W, 0402	0402	CRCW0402976KFKED	Vishay-Dale
R2	1	150	RES, 150 ohm, 1%, 0.1W, 0603	0603	CRCW0603150RFKEA	Vishay-Dale

Table 3. bq51025EVM-649 Bill of Materials (continued)

Designator	Quantity	Value	Description	PackageReference	PartNumber	Manufacturer
R3	1	102k	RES, 102k ohm, 1%, 0.063W, 0402	0402	CRCW0402102KFKEA	Vishay-Dale
R4	1	237	RES, 237 ohm, 1%, 0.1W, 0603	0603	CRCW0603237RFKEA	Vishay-Dale
R5, R6, R14	3	500 Ohm	Trimmer, 500 ohm, 0.25W, TH	4.5x8x6.7mm	3266W-1-501LF	Bourns
R7	1	1.50k	RES, 1.50k ohm, 1%, 0.1W, 0603	0603	CRCW06031K50FKEA	Vishay-Dale
R8, R9	2	200	RES, 200, 1%, 0.1 W, 0603	0603	CRCW0603200RFKEA	Vishay-Dale
R10, R12	2	10.0k	RES, 10.0k ohm, 1%, 0.1W, 0603	0603	CRCW060310K0FKEA	Vishay-Dale
R11	1	10.0k	RES, 10.0k ohm, 1%, 0.063W, 0402	0402	CRCW040210K0FKED	Vishay-Dale
R13	1	5.62Meg	RES, 5.62Meg ohm, 1%, 0.1W, 0603	0603	CRCW06035M62FKEA	Vishay-Dale
R16	1	20.0k	RES, 20.0k ohm, 1%, 0.1W, 0603	0603	CRCW060320K0FKEA	Vishay-Dale
R17	1	150k	RES, 150k ohm, 1%, 0.1W, 0603	0603	CRCW0603150KFKEA	Vishay-Dale
R18, R19	2	130k	RES, 130k ohm, 1%, 0.1W, 0603	0603	CRCW0603130KFKEA	Vishay-Dale
SH-JP1, SH-JP2	2	1x2	Shunt, 100mil, Gold plated, Black	Shunt	969102-0000-DA	3M
TP1, TP2, TP4, TP9	4	Black	Test Point, Miniature, Black, TH	Black Miniature Testpoint	5001	Keystone
TP3, TP7, TP8, TP10, TP11, TP12	6	White	Test Point, TH, Miniature, White	Keystone5002	5002	Keystone
U1	1		10-W Qi INTEGRATED WIRELESS RECEIVER POWER SUPPLY, YFP0042AWCG	YFP0042AWCG	bq51025YFP	Texas Instruments
C2	0	0.068uF	CAP, CERM, 0.068uF, 50V, +/-5%, COG/NP0, 1206	1206	GRM31C5C1H683JA01L	MuRata
FID1, FID2, FID3	0		Fiducial mark. There is nothing to buy or mount.	Fiducial	N/A	N/A
R15	0	0	RES, 0 ohm, 5%, 0.1W, 0603	0603	CRCW06030000Z0EA	Vishay-Dale
TP5, TP6	0	Black	Test Point, Miniature, Black, TH	Black Miniature Testpoint	5001	Keystone

STANDARD TERMS AND CONDITIONS FOR EVALUATION MODULES

1. *Delivery:* TI delivers TI evaluation boards, kits, or modules, including any accompanying demonstration software, components, or documentation (collectively, an "EVM" or "EVMs") to the User ("User") in accordance with the terms and conditions set forth herein. Acceptance of the EVM is expressly subject to the following terms and conditions.
 - 1.1 EVMs are intended solely for product or software developers for use in a research and development setting to facilitate feasibility evaluation, experimentation, or scientific analysis of TI semiconductors products. EVMs have no direct function and are not finished products. EVMs shall not be directly or indirectly assembled as a part or subassembly in any finished product. For clarification, any software or software tools provided with the EVM ("Software") shall not be subject to the terms and conditions set forth herein but rather shall be subject to the applicable terms and conditions that accompany such Software
 - 1.2 EVMs are not intended for consumer or household use. EVMs may not be sold, sublicensed, leased, rented, loaned, assigned, or otherwise distributed for commercial purposes by Users, in whole or in part, or used in any finished product or production system.
2. *Limited Warranty and Related Remedies/Disclaimers:*
 - 2.1 These terms and conditions do not apply to Software. The warranty, if any, for Software is covered in the applicable Software License Agreement.
 - 2.2 TI warrants that the TI EVM will conform to TI's published specifications for ninety (90) days after the date TI delivers such EVM to User. Notwithstanding the foregoing, TI shall not be liable for any defects that are caused by neglect, misuse or mistreatment by an entity other than TI, including improper installation or testing, or for any EVMs that have been altered or modified in any way by an entity other than TI. Moreover, TI shall not be liable for any defects that result from User's design, specifications or instructions for such EVMs. Testing and other quality control techniques are used to the extent TI deems necessary or as mandated by government requirements. TI does not test all parameters of each EVM.
 - 2.3 If any EVM fails to conform to the warranty set forth above, TI's sole liability shall be at its option to repair or replace such EVM, or credit User's account for such EVM. TI's liability under this warranty shall be limited to EVMs that are returned during the warranty period to the address designated by TI and that are determined by TI not to conform to such warranty. If TI elects to repair or replace such EVM, TI shall have a reasonable time to repair such EVM or provide replacements. Repaired EVMs shall be warranted for the remainder of the original warranty period. Replaced EVMs shall be warranted for a new full ninety (90) day warranty period.
3. *Regulatory Notices:*
 - 3.1 *United States*
 - 3.1.1 *Notice applicable to EVMs not FCC-Approved:*

This kit is designed to allow product developers to evaluate electronic components, circuitry, or software associated with the kit to determine whether to incorporate such items in a finished product and software developers to write software applications for use with the end product. This kit is not a finished product and when assembled may not be resold or otherwise marketed unless all required FCC equipment authorizations are first obtained. Operation is subject to the condition that this product not cause harmful interference to licensed radio stations and that this product accept harmful interference. Unless the assembled kit is designed to operate under part 15, part 18 or part 95 of this chapter, the operator of the kit must operate under the authority of an FCC license holder or must secure an experimental authorization under part 5 of this chapter.
 - 3.1.2 *For EVMs annotated as FCC – FEDERAL COMMUNICATIONS COMMISSION Part 15 Compliant:*

CAUTION

This device complies with part 15 of the FCC Rules. Operation is subject to the following two conditions: (1) This device may not cause harmful interference, and (2) this device must accept any interference received, including interference that may cause undesired operation.

Changes or modifications not expressly approved by the party responsible for compliance could void the user's authority to operate the equipment.

FCC Interference Statement for Class A EVM devices

NOTE: This equipment has been tested and found to comply with the limits for a Class A digital device, pursuant to part 15 of the FCC Rules. These limits are designed to provide reasonable protection against harmful interference when the equipment is operated in a commercial environment. This equipment generates, uses, and can radiate radio frequency energy and, if not installed and used in accordance with the instruction manual, may cause harmful interference to radio communications. Operation of this equipment in a residential area is likely to cause harmful interference in which case the user will be required to correct the interference at his own expense.

FCC Interference Statement for Class B EVM devices

NOTE: This equipment has been tested and found to comply with the limits for a Class B digital device, pursuant to part 15 of the FCC Rules. These limits are designed to provide reasonable protection against harmful interference in a residential installation. This equipment generates, uses and can radiate radio frequency energy and, if not installed and used in accordance with the instructions, may cause harmful interference to radio communications. However, there is no guarantee that interference will not occur in a particular installation. If this equipment does cause harmful interference to radio or television reception, which can be determined by turning the equipment off and on, the user is encouraged to try to correct the interference by one or more of the following measures:

- Reorient or relocate the receiving antenna.
- Increase the separation between the equipment and receiver.
- Connect the equipment into an outlet on a circuit different from that to which the receiver is connected.
- Consult the dealer or an experienced radio/TV technician for help.

3.2 Canada

3.2.1 For EVMs issued with an Industry Canada Certificate of Conformance to RSS-210

Concerning EVMs Including Radio Transmitters:

This device complies with Industry Canada license-exempt RSS standard(s). Operation is subject to the following two conditions: (1) this device may not cause interference, and (2) this device must accept any interference, including interference that may cause undesired operation of the device.

Concernant les EVMs avec appareils radio:

Le présent appareil est conforme aux CNR d'Industrie Canada applicables aux appareils radio exempts de licence. L'exploitation est autorisée aux deux conditions suivantes: (1) l'appareil ne doit pas produire de brouillage, et (2) l'utilisateur de l'appareil doit accepter tout brouillage radioélectrique subi, même si le brouillage est susceptible d'en compromettre le fonctionnement.

Concerning EVMs Including Detachable Antennas:

Under Industry Canada regulations, this radio transmitter may only operate using an antenna of a type and maximum (or lesser) gain approved for the transmitter by Industry Canada. To reduce potential radio interference to other users, the antenna type and its gain should be so chosen that the equivalent isotropically radiated power (e.i.r.p.) is not more than that necessary for successful communication. This radio transmitter has been approved by Industry Canada to operate with the antenna types listed in the user guide with the maximum permissible gain and required antenna impedance for each antenna type indicated. Antenna types not included in this list, having a gain greater than the maximum gain indicated for that type, are strictly prohibited for use with this device.

Concernant les EVMs avec antennes détachables

Conformément à la réglementation d'Industrie Canada, le présent émetteur radio peut fonctionner avec une antenne d'un type et d'un gain maximal (ou inférieur) approuvé pour l'émetteur par Industrie Canada. Dans le but de réduire les risques de brouillage radioélectrique à l'intention des autres utilisateurs, il faut choisir le type d'antenne et son gain de sorte que la puissance isotrope rayonnée équivalente (p.i.r.e.) ne dépasse pas l'intensité nécessaire à l'établissement d'une communication satisfaisante. Le présent émetteur radio a été approuvé par Industrie Canada pour fonctionner avec les types d'antenne énumérés dans le manuel d'usage et ayant un gain admissible maximal et l'impédance requise pour chaque type d'antenne. Les types d'antenne non inclus dans cette liste, ou dont le gain est supérieur au gain maximal indiqué, sont strictement interdits pour l'exploitation de l'émetteur.

3.3 Japan

3.3.1 *Notice for EVMs delivered in Japan:* Please see http://www.tij.co.jp/lstds/ti_ja/general/eStore/notice_01.page 日本国内に輸入される評価用キット、ボードについては、次のところをご覧ください。
http://www.tij.co.jp/lstds/ti_ja/general/eStore/notice_01.page

3.3.2 *Notice for Users of EVMs Considered "Radio Frequency Products" in Japan:* EVMs entering Japan are NOT certified by TI as conforming to Technical Regulations of Radio Law of Japan.

If User uses EVMs in Japan, User is required by Radio Law of Japan to follow the instructions below with respect to EVMs:

1. Use EVMs in a shielded room or any other test facility as defined in the notification #173 issued by Ministry of Internal Affairs and Communications on March 28, 2006, based on Sub-section 1.1 of Article 6 of the Ministry's Rule for Enforcement of Radio Law of Japan,
2. Use EVMs only after User obtains the license of Test Radio Station as provided in Radio Law of Japan with respect to EVMs, or
3. Use of EVMs only after User obtains the Technical Regulations Conformity Certification as provided in Radio Law of Japan with respect to EVMs. Also, do not transfer EVMs, unless User gives the same notice above to the transferee. Please note that if User does not follow the instructions above, User will be subject to penalties of Radio Law of Japan.

【無線電波を送信する製品の開発キットをお使いになる際の注意事項】

本開発キットは技術基準適合証明を受けておりません。

本製品のご使用に際しては、電波法遵守のため、以下のいずれかの措置を取っていただく必要がありますのでご注意ください。

1. 電波法施行規則第6条第1項第1号に基づく平成18年3月28日総務省告示第173号で定められた電波暗室等の試験設備でご使用いただく。
2. 実験局の免許を取得後ご使用いただく。
3. 技術基準適合証明を取得後ご使用いただく。

なお、本製品は、上記の「ご使用にあたっての注意」を譲渡先、移転先に通知しない限り、譲渡、移転できないものとします。

上記を遵守頂けない場合は、電波法の罰則が適用される可能性があることをご留意ください。

日本テキサス・インスツルメンツ株式会社

東京都新宿区西新宿 6 丁目 2 4 番 1 号

西新宿三井ビル

3.3.3 *Notice for EVMs for Power Line Communication:* Please see http://www.tij.co.jp/llds/ti_ja/general/eStore/notice_02.page

電力線搬送波通信についての開発キットをお使いになる際の注意事項については、次のところをご覧ください。http://www.tij.co.jp/llds/ti_ja/general/eStore/notice_02.page

4 *EVM Use Restrictions and Warnings:*

4.1 EVMS ARE NOT FOR USE IN FUNCTIONAL SAFETY AND/OR SAFETY CRITICAL EVALUATIONS, INCLUDING BUT NOT LIMITED TO EVALUATIONS OF LIFE SUPPORT APPLICATIONS.

4.2 User must read and apply the user guide and other available documentation provided by TI regarding the EVM prior to handling or using the EVM, including without limitation any warning or restriction notices. The notices contain important safety information related to, for example, temperatures and voltages.

4.3 *Safety-Related Warnings and Restrictions:*

4.3.1 User shall operate the EVM within TI's recommended specifications and environmental considerations stated in the user guide, other available documentation provided by TI, and any other applicable requirements and employ reasonable and customary safeguards. Exceeding the specified performance ratings and specifications (including but not limited to input and output voltage, current, power, and environmental ranges) for the EVM may cause personal injury or death, or property damage. If there are questions concerning performance ratings and specifications, User should contact a TI field representative prior to connecting interface electronics including input power and intended loads. Any loads applied outside of the specified output range may also result in unintended and/or inaccurate operation and/or possible permanent damage to the EVM and/or interface electronics. Please consult the EVM user guide prior to connecting any load to the EVM output. If there is uncertainty as to the load specification, please contact a TI field representative. During normal operation, even with the inputs and outputs kept within the specified allowable ranges, some circuit components may have elevated case temperatures. These components include but are not limited to linear regulators, switching transistors, pass transistors, current sense resistors, and heat sinks, which can be identified using the information in the associated documentation. When working with the EVM, please be aware that the EVM may become very warm.

4.3.2 EVMs are intended solely for use by technically qualified, professional electronics experts who are familiar with the dangers and application risks associated with handling electrical mechanical components, systems, and subsystems. User assumes all responsibility and liability for proper and safe handling and use of the EVM by User or its employees, affiliates, contractors or designees. User assumes all responsibility and liability to ensure that any interfaces (electronic and/or mechanical) between the EVM and any human body are designed with suitable isolation and means to safely limit accessible leakage currents to minimize the risk of electrical shock hazard. User assumes all responsibility and liability for any improper or unsafe handling or use of the EVM by User or its employees, affiliates, contractors or designees.

4.4 User assumes all responsibility and liability to determine whether the EVM is subject to any applicable international, federal, state, or local laws and regulations related to User's handling and use of the EVM and, if applicable, User assumes all responsibility and liability for compliance in all respects with such laws and regulations. User assumes all responsibility and liability for proper disposal and recycling of the EVM consistent with all applicable international, federal, state, and local requirements.

5. *Accuracy of Information:* To the extent TI provides information on the availability and function of EVMs, TI attempts to be as accurate as possible. However, TI does not warrant the accuracy of EVM descriptions, EVM availability or other information on its websites as accurate, complete, reliable, current, or error-free.

6. *Disclaimers:*
- 6.1 EXCEPT AS SET FORTH ABOVE, EVMS AND ANY WRITTEN DESIGN MATERIALS PROVIDED WITH THE EVM (AND THE DESIGN OF THE EVM ITSELF) ARE PROVIDED "AS IS" AND "WITH ALL FAULTS." TI DISCLAIMS ALL OTHER WARRANTIES, EXPRESS OR IMPLIED, REGARDING SUCH ITEMS, INCLUDING BUT NOT LIMITED TO ANY IMPLIED WARRANTIES OF MERCHANTABILITY OR FITNESS FOR A PARTICULAR PURPOSE OR NON-INFRINGEMENT OF ANY THIRD PARTY PATENTS, COPYRIGHTS, TRADE SECRETS OR OTHER INTELLECTUAL PROPERTY RIGHTS.
 - 6.2 EXCEPT FOR THE LIMITED RIGHT TO USE THE EVM SET FORTH HEREIN, NOTHING IN THESE TERMS AND CONDITIONS SHALL BE CONSTRUED AS GRANTING OR CONFERRING ANY RIGHTS BY LICENSE, PATENT, OR ANY OTHER INDUSTRIAL OR INTELLECTUAL PROPERTY RIGHT OF TI, ITS SUPPLIERS/LICENSORS OR ANY OTHER THIRD PARTY, TO USE THE EVM IN ANY FINISHED END-USER OR READY-TO-USE FINAL PRODUCT, OR FOR ANY INVENTION, DISCOVERY OR IMPROVEMENT MADE, CONCEIVED OR ACQUIRED PRIOR TO OR AFTER DELIVERY OF THE EVM.
7. *USER'S INDEMNITY OBLIGATIONS AND REPRESENTATIONS.* USER WILL DEFEND, INDEMNIFY AND HOLD TI, ITS LICENSORS AND THEIR REPRESENTATIVES HARMLESS FROM AND AGAINST ANY AND ALL CLAIMS, DAMAGES, LOSSES, EXPENSES, COSTS AND LIABILITIES (COLLECTIVELY, "CLAIMS") ARISING OUT OF OR IN CONNECTION WITH ANY HANDLING OR USE OF THE EVM THAT IS NOT IN ACCORDANCE WITH THESE TERMS AND CONDITIONS. THIS OBLIGATION SHALL APPLY WHETHER CLAIMS ARISE UNDER STATUTE, REGULATION, OR THE LAW OF TORT, CONTRACT OR ANY OTHER LEGAL THEORY, AND EVEN IF THE EVM FAILS TO PERFORM AS DESCRIBED OR EXPECTED.
8. *Limitations on Damages and Liability:*
- 8.1 *General Limitations.* IN NO EVENT SHALL TI BE LIABLE FOR ANY SPECIAL, COLLATERAL, INDIRECT, PUNITIVE, INCIDENTAL, CONSEQUENTIAL, OR EXEMPLARY DAMAGES IN CONNECTION WITH OR ARISING OUT OF THESE TERMS AND CONDITIONS OR THE USE OF THE EVMS PROVIDED HEREUNDER, REGARDLESS OF WHETHER TI HAS BEEN ADVISED OF THE POSSIBILITY OF SUCH DAMAGES. EXCLUDED DAMAGES INCLUDE, BUT ARE NOT LIMITED TO, COST OF REMOVAL OR REINSTALLATION, ANCILLARY COSTS TO THE PROCUREMENT OF SUBSTITUTE GOODS OR SERVICES, RETESTING, OUTSIDE COMPUTER TIME, LABOR COSTS, LOSS OF GOODWILL, LOSS OF PROFITS, LOSS OF SAVINGS, LOSS OF USE, LOSS OF DATA, OR BUSINESS INTERRUPTION. NO CLAIM, SUIT OR ACTION SHALL BE BROUGHT AGAINST TI MORE THAN ONE YEAR AFTER THE RELATED CAUSE OF ACTION HAS OCCURRED.
 - 8.2 *Specific Limitations.* IN NO EVENT SHALL TI'S AGGREGATE LIABILITY FROM ANY WARRANTY OR OTHER OBLIGATION ARISING OUT OF OR IN CONNECTION WITH THESE TERMS AND CONDITIONS, OR ANY USE OF ANY TI EVM PROVIDED HEREUNDER, EXCEED THE TOTAL AMOUNT PAID TO TI FOR THE PARTICULAR UNITS SOLD UNDER THESE TERMS AND CONDITIONS WITH RESPECT TO WHICH LOSSES OR DAMAGES ARE CLAIMED. THE EXISTENCE OF MORE THAN ONE CLAIM AGAINST THE PARTICULAR UNITS SOLD TO USER UNDER THESE TERMS AND CONDITIONS SHALL NOT ENLARGE OR EXTEND THIS LIMIT.
9. *Return Policy.* Except as otherwise provided, TI does not offer any refunds, returns, or exchanges. Furthermore, no return of EVM(s) will be accepted if the package has been opened and no return of the EVM(s) will be accepted if they are damaged or otherwise not in a resalable condition. If User feels it has been incorrectly charged for the EVM(s) it ordered or that delivery violates the applicable order, User should contact TI. All refunds will be made in full within thirty (30) working days from the return of the components(s), excluding any postage or packaging costs.
10. *Governing Law:* These terms and conditions shall be governed by and interpreted in accordance with the laws of the State of Texas, without reference to conflict-of-laws principles. User agrees that non-exclusive jurisdiction for any dispute arising out of or relating to these terms and conditions lies within courts located in the State of Texas and consents to venue in Dallas County, Texas. Notwithstanding the foregoing, any judgment may be enforced in any United States or foreign court, and TI may seek injunctive relief in any United States or foreign court.

IMPORTANT NOTICE

Texas Instruments Incorporated and its subsidiaries (TI) reserve the right to make corrections, enhancements, improvements and other changes to its semiconductor products and services per JESD46, latest issue, and to discontinue any product or service per JESD48, latest issue. Buyers should obtain the latest relevant information before placing orders and should verify that such information is current and complete. All semiconductor products (also referred to herein as "components") are sold subject to TI's terms and conditions of sale supplied at the time of order acknowledgment.

TI warrants performance of its components to the specifications applicable at the time of sale, in accordance with the warranty in TI's terms and conditions of sale of semiconductor products. Testing and other quality control techniques are used to the extent TI deems necessary to support this warranty. Except where mandated by applicable law, testing of all parameters of each component is not necessarily performed.

TI assumes no liability for applications assistance or the design of Buyers' products. Buyers are responsible for their products and applications using TI components. To minimize the risks associated with Buyers' products and applications, Buyers should provide adequate design and operating safeguards.

TI does not warrant or represent that any license, either express or implied, is granted under any patent right, copyright, mask work right, or other intellectual property right relating to any combination, machine, or process in which TI components or services are used. Information published by TI regarding third-party products or services does not constitute a license to use such products or services or a warranty or endorsement thereof. Use of such information may require a license from a third party under the patents or other intellectual property of the third party, or a license from TI under the patents or other intellectual property of TI.

Reproduction of significant portions of TI information in TI data books or data sheets is permissible only if reproduction is without alteration and is accompanied by all associated warranties, conditions, limitations, and notices. TI is not responsible or liable for such altered documentation. Information of third parties may be subject to additional restrictions.

Resale of TI components or services with statements different from or beyond the parameters stated by TI for that component or service voids all express and any implied warranties for the associated TI component or service and is an unfair and deceptive business practice. TI is not responsible or liable for any such statements.

Buyer acknowledges and agrees that it is solely responsible for compliance with all legal, regulatory and safety-related requirements concerning its products, and any use of TI components in its applications, notwithstanding any applications-related information or support that may be provided by TI. Buyer represents and agrees that it has all the necessary expertise to create and implement safeguards which anticipate dangerous consequences of failures, monitor failures and their consequences, lessen the likelihood of failures that might cause harm and take appropriate remedial actions. Buyer will fully indemnify TI and its representatives against any damages arising out of the use of any TI components in safety-critical applications.

In some cases, TI components may be promoted specifically to facilitate safety-related applications. With such components, TI's goal is to help enable customers to design and create their own end-product solutions that meet applicable functional safety standards and requirements. Nonetheless, such components are subject to these terms.

No TI components are authorized for use in FDA Class III (or similar life-critical medical equipment) unless authorized officers of the parties have executed a special agreement specifically governing such use.

Only those TI components which TI has specifically designated as military grade or "enhanced plastic" are designed and intended for use in military/aerospace applications or environments. Buyer acknowledges and agrees that any military or aerospace use of TI components which have **not** been so designated is solely at the Buyer's risk, and that Buyer is solely responsible for compliance with all legal and regulatory requirements in connection with such use.

TI has specifically designated certain components as meeting ISO/TS16949 requirements, mainly for automotive use. In any case of use of non-designated products, TI will not be responsible for any failure to meet ISO/TS16949.

Products

Audio	www.ti.com/audio
Amplifiers	amplifier.ti.com
Data Converters	dataconverter.ti.com
DLP® Products	www.dlp.com
DSP	dsp.ti.com
Clocks and Timers	www.ti.com/clocks
Interface	interface.ti.com
Logic	logic.ti.com
Power Mgmt	power.ti.com
Microcontrollers	microcontroller.ti.com
RFID	www.ti-rfid.com
OMAP Applications Processors	www.ti.com/omap
Wireless Connectivity	www.ti.com/wirelessconnectivity

Applications

Automotive and Transportation	www.ti.com/automotive
Communications and Telecom	www.ti.com/communications
Computers and Peripherals	www.ti.com/computers
Consumer Electronics	www.ti.com/consumer-apps
Energy and Lighting	www.ti.com/energy
Industrial	www.ti.com/industrial
Medical	www.ti.com/medical
Security	www.ti.com/security
Space, Avionics and Defense	www.ti.com/space-avionics-defense
Video and Imaging	www.ti.com/video

TI E2E Community

e2e.ti.com