

Evaluation Board for Active EMI Filters with Hot-Swap

The QPI-8 Evaluation board provides an easy to use evaluation platform for testing the QPI-8 EMI filter with Hot-Swap in existing or prototype systems. The board comes with a mounted QPI-8, RPG (PWRGD=Power Good) pull-up resistor, ROV and RUVEN jumper resistors, and screwterminal blocks for electrical connections.

External resistors can be used in series with the UVEN and OV inputs to the BUS+ terminal to increase the threshold voltages or connected directly for minimum specified thresholds. Values can be determined using figure 6 of the datasheet to trim these parameters up to the desired levels. Optional C2 capacitor is described for hold-up considerations during a power dropout and C3 can be added to filter nuisance over voltage low energy spikes that do not merit a shutdown condition.

Please refer to the QPI-8 datasheet for detailed description and typical operation of the product when applying this evaluation board. Specifically refer to Figures 9a and 9b in the datasheet for detailed application circuits.

Also refer to QPI-AN1 for critical PCB layout and EMI considerations for QPI products in general but refer to the individual product specifications for their PCB layout footprint and pin-out.

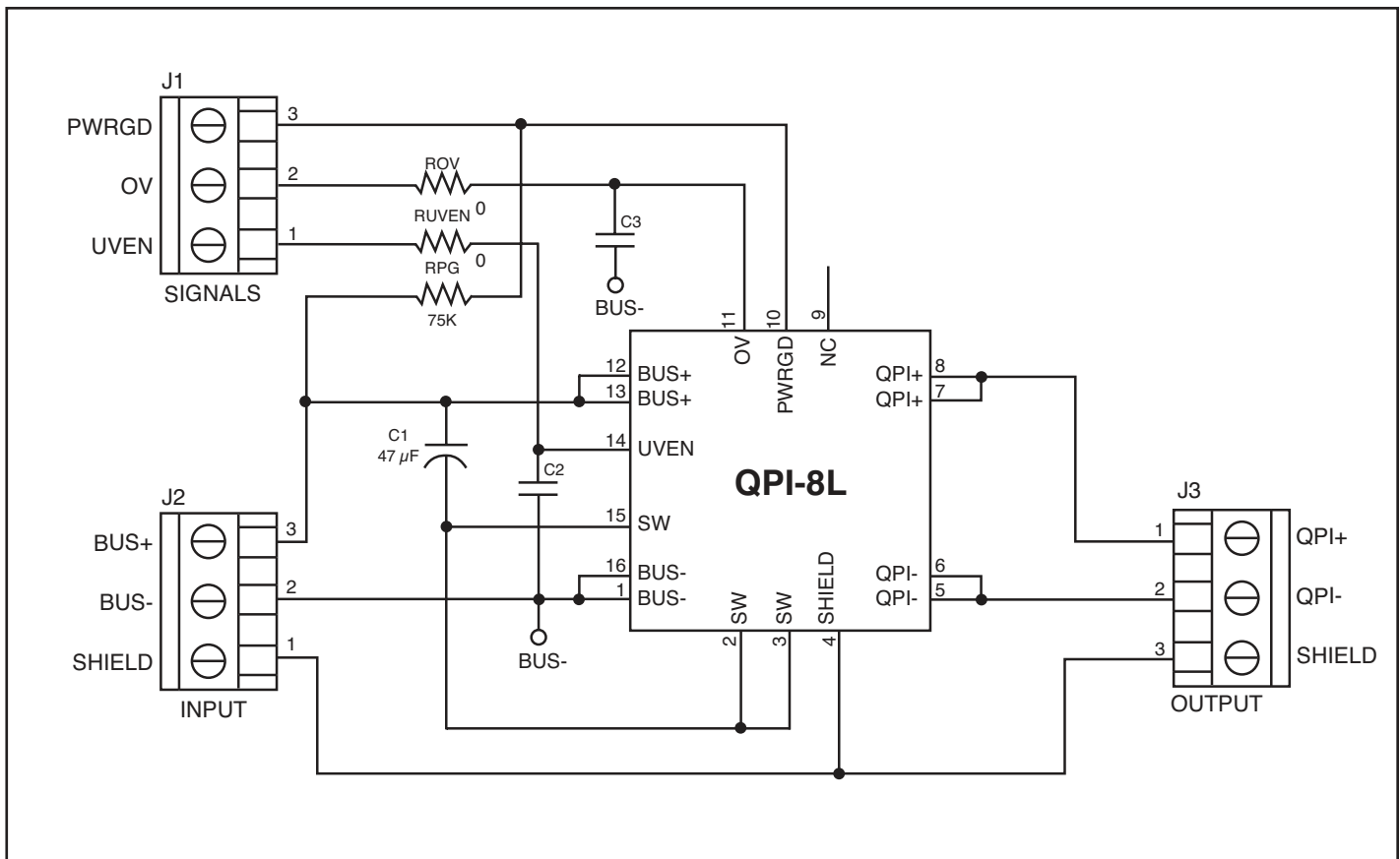

Figure 1 - Evaluation board schematic

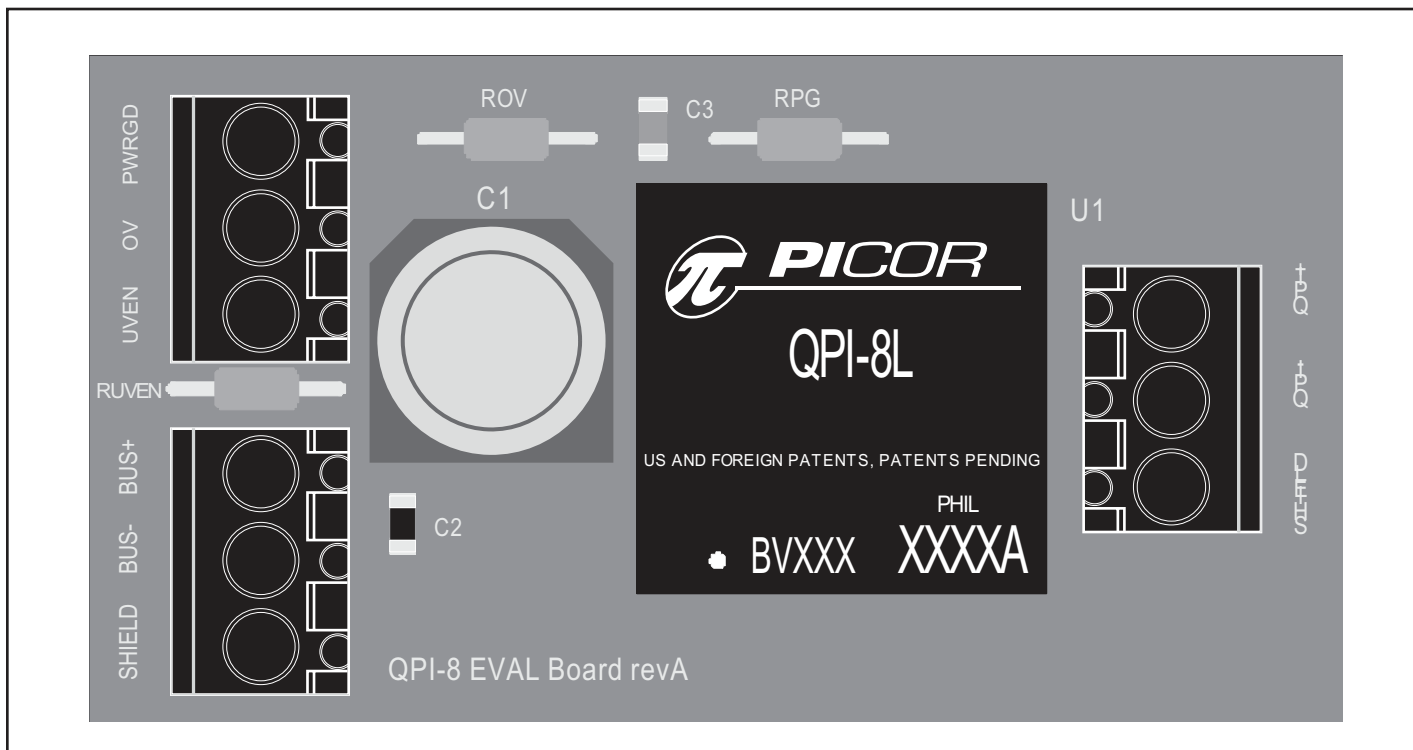

Figure 2 - Evaluation board layout

Ordering Information

Part Number	Description
QPI-8 EVAL1	Evaluation board for QP8-1L

Vicor's comprehensive line of power solutions includes high-density AC-DC & DC-DC modules and accessory components, fully configurable AC-DC & DC-DC power supplies, and complete custom power systems.

Information furnished by Vicor is believed to be accurate and reliable. However, no responsibility is assumed by Vicor for its use. No license is granted by implication or otherwise under any patent or patent rights of Vicor. Vicor components are not designed to be used in applications, such as life support systems, wherein a failure or malfunction could result in injury or death. All sales are subject to Vicor's Terms and Conditions of Sale, which are available upon request.

Specifications are subject to change without notice.



Vicor Corporation
 25 Frontage Road, Andover, MA, USA 01810
 Tel: 800-735-6200 Fax: 978-475-6715

Email
 Vicor Express: vicorexp@vicor.com
 Technical Support: apps@vicor.com