

17V, Dual 1A, Synchronous Step-Down Regulator with Ultralow Quiescent Current

DESCRIPTION

Demonstration circuit 2003A is a synchronous step-down regulator using the power-saving [LTC3622EDE](#) monolithic buck regulator in a compact 14-pin DFN (4mm × 3mm) package. The DC2003A operates from an input voltage range of 2.7V to 17V and provides dual 1A outputs with an adjustable output voltage range from 1.2V to 5V. The LTC3622 IC quiescent current can be as low as 5μA in Burst Mode[®] operation with both channels enabled and less than 0.1μA in shutdown mode. The switching frequency is fixed to 1MHz or 2.25MHz with a ±50% synchronization range to an external clock. A user-selectable mode input is provided to allow the user to trade off ripple noise for

light load efficiency. Burst Mode operation provides the highest efficiency at light loads, while pulse-skipping mode provides the lowest ripple noise.

It is recommended to read the data sheet LTC3622 with this demo manual prior to working on or making any changes to DC2003A.

Design files for this circuit board are available at <http://www.linear.com/demo>

LT, LT, LTC, LTM, Linear Technology, Burst Mode and the Linear logo are registered trademarks of Linear Technology Corporation. All other trademarks are the property of their respective owners.

PERFORMANCE SUMMARY Specifications are at T_A = 25°C

PARAMETER	CONDITIONS	VALUE
Default IC		LTC3622EDE
Default Switching Frequency		1MHz
Default Operation Mode		Burst Mode Operation
Input Voltage Range		2.7V to 17V
Onboard User Selectable Output Voltages	V _{IN} = 2.7V to 17V, I _{OUT1} = I _{OUT2} = 0A to 1A (V _{OUT} ≤ V _{IN})	V _{OUT1} : 1.2V, 1.8V, 2.5V, 3.3V V _{OUT2} : 1.5V, 1.8V, 3.3V, 5V
Default Output Voltage		V _{OUT1} = 3.3V V _{OUT2} = 5V
Per Channel Maximum Continuous Output Current	V _{IN} = 2.7V to 17V	I _{OUT1} = I _{OUT2} = 1A
Efficiency, V _{OUT1} (Burst Mode Operation)	V _{IN} = 12V, V _{OUT1} = 3.3V, I _{OUT1} = 1A	88.2% (See Figure 3)
Efficiency, V _{OUT2} (Burst Mode Operation)	V _{IN} = 12V, V _{OUT2} = 5V, I _{OUT2} = 1A	90.8% (See Figure 4)
Output Voltage Ripple, V _{OUT1}	V _{IN} = 12V, V _{OUT1} = 3.3V, I _{OUT1} = 1A	<5.9mV _{p-p} (See Figure 5)
Output Voltage Ripple, V _{OUT2}	V _{IN} = 12V, V _{OUT2} = 5V, I _{OUT2} = 1A	<7.8mV _{p-p} (See Figure 6)
Load Transient Response, V _{OUT1}	V _{IN} = 12V, V _{OUT1} = 3.3V, I _{OUT1} = 100mA to 1A	See Figure 7
Load Transient Response, V _{OUT2}	V _{IN} = 12V, V _{OUT2} = 5V, I _{OUT2} = 100mA to 1A	See Figure 8
Thermal Image	V _{IN} = 12V, V _{OUT1} = 3.3V, V _{OUT2} = 5V, I _{OUT1} = I _{OUT2} = 1A	See Figure 9

QUICK START PROCEDURE

Demonstration circuit 2003A is easy to set up to evaluate the performance of the LTC3622. Please refer to Figure 1 for proper measurement equipment setup and follow the procedure below:

- Place jumpers in the following positions:

Table 1. Jumper Selection

JP1	JP2	JP3	JP4	JP5
RUN1	RUN2	MODE/SYNC	PHASE	ILIM
ON	ON	BURST	180°	1A

- Place VO1 SELECT jumper in 3.3V position (JP9) and VO2 SELECT jumper in 5V position (JP14).
- With power off, connect the input power supply at V_{IN1} and GND.
- Connect the Loads between V_{OUT1} and GND, V_{OUT2} and GND. Preset the loads to 0A.
- Connect the DMMs to the input and output to monitor the input voltage and output voltages.
- Turn on the power supply at the input. The RUN1 and RUN2 pin jumpers should be at ON position. Measure and make sure the input supply voltage is 12V. The output voltage V_{OUT1} should be $3.3V \pm 1\%$, and V_{OUT2} should be $5V \pm 1\%$.
- Once the input and output voltages are properly established adjust the loads within the operating range (0A to 1A max) and observe the output voltage regulations, output ripple voltages, switch node wave-forms and other parameters. Refer to Figure 2 for proper input/output voltage ripple measurement.

- To select other output voltages, use the on board user selectable output voltage jumpers. Shutting down LTC3622 by placing RUN1 and RUN2 pin jumpers to the OFF position or turn off the input power supply. Refer to the following tables (Table 2 and Table 3) for the output voltage selections and repeat step 3 to 6:

Table 2. V_{OUT1} Jumper Selection

JP6	JP7	JP8	JP9	JP10
1.2V	1.8V	2.5V	3.3V	*USER SELECT

Table 3. V_{OUT2} Jumper Selection

JP11	JP12	JP13	JP14	JP15
1.5V	1.8V	3.3V	5V	*USER SELECT

***Note:** If JP10 or JP15 is selected, R5 or R15 needs to be calculated and inserted to obtain the desired output voltage.

Note 1: To measure the input/output voltage ripple properly, do not use the long ground lead on the oscilloscope probe. See Figure 2 for the proper scope probe technique. Short, stiff leads need to be soldered to the (+) and (-) terminals of an output capacitor. The probe's ground ring needs to touch the (-) lead and the probe tip needs to touch the (+) lead.

Note 2: DC2003A can also be used to evaluate LTC3622EDE-2 (2.25MHz) by simply changing U1 to LTC3622EDE-2, L1 to $1\mu\text{H}$ (Coilcraft XFL4020-102ME) and L2 to $2.2\mu\text{H}$ (Coilcraft XFL4020-222ME).

QUICK START PROCEDURE

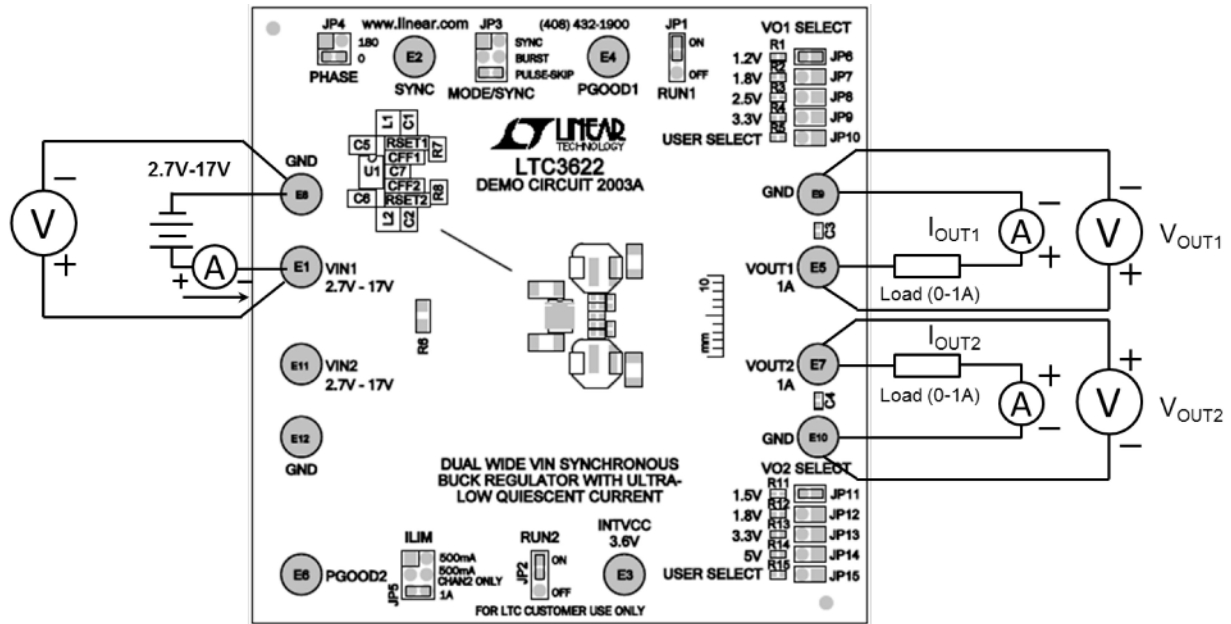

Figure 1. Proper Equipment Measurement Setup

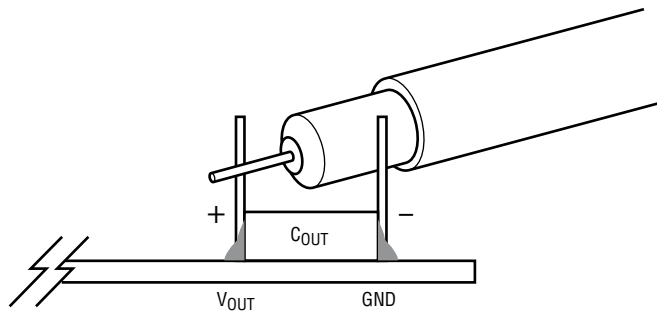

Figure 2. Scope Probe Placements for Measuring Input or Output Ripple

QUICK START PROCEDURE

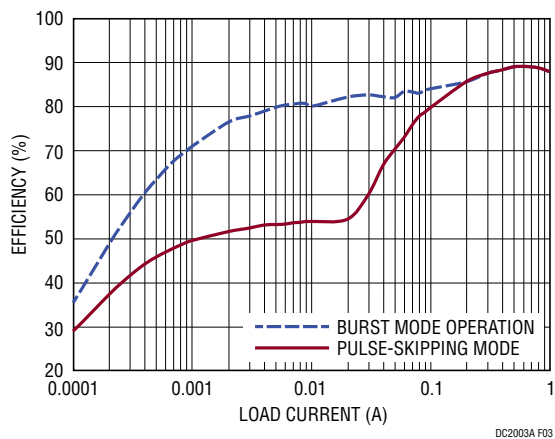

Figure 3. V_{OUT1} Measured Efficiency at $V_{IN} = 12V$, $V_{OUT1} = 3.3V$, $L1 = 3.3\mu H$, $F_{SW} = 1MHz$ (with V_{OUT2} OFF)

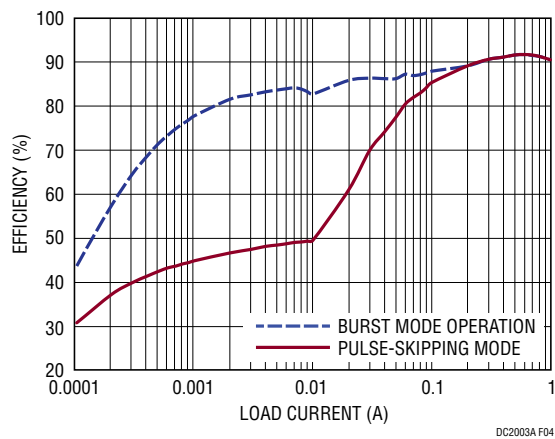

Figure 4. V_{OUT2} Measured Efficiency at $V_{IN} = 12V$, $V_{OUT2} = 5V$, $L2 = 4.7\mu H$, $F_{SW} = 1MHz$ (with V_{OUT1} OFF)

QUICK START PROCEDURE

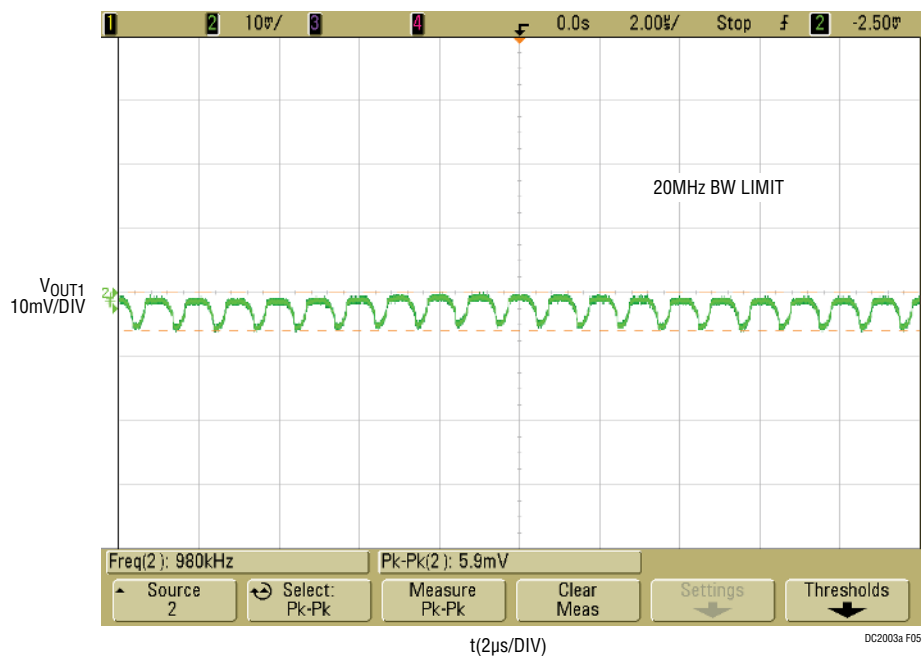

Figure 5. V_{OUT1} Measured Output Voltage Ripple at V_{IN} = 12V, V_{OUT1} = 3.3V, I_{OUT1} = 1A, F_{SW} = 1MHz

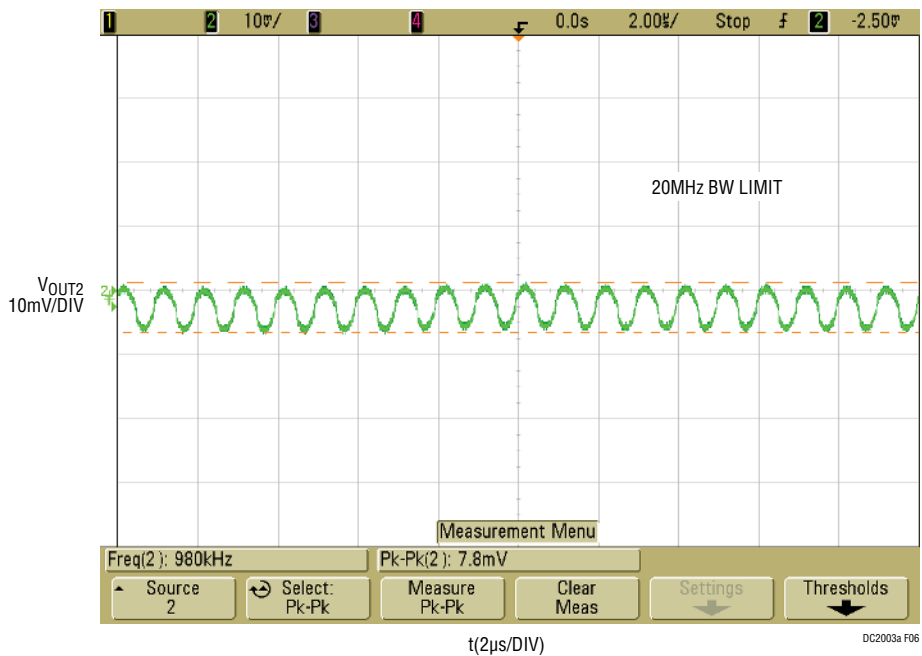

Figure 6. V_{OUT2} Measured Output Voltage Ripple at V_{IN} = 12V, V_{OUT2} = 5V, I_{OUT2} = 1A, F_{SW} = 1MHz

QUICK START PROCEDURE

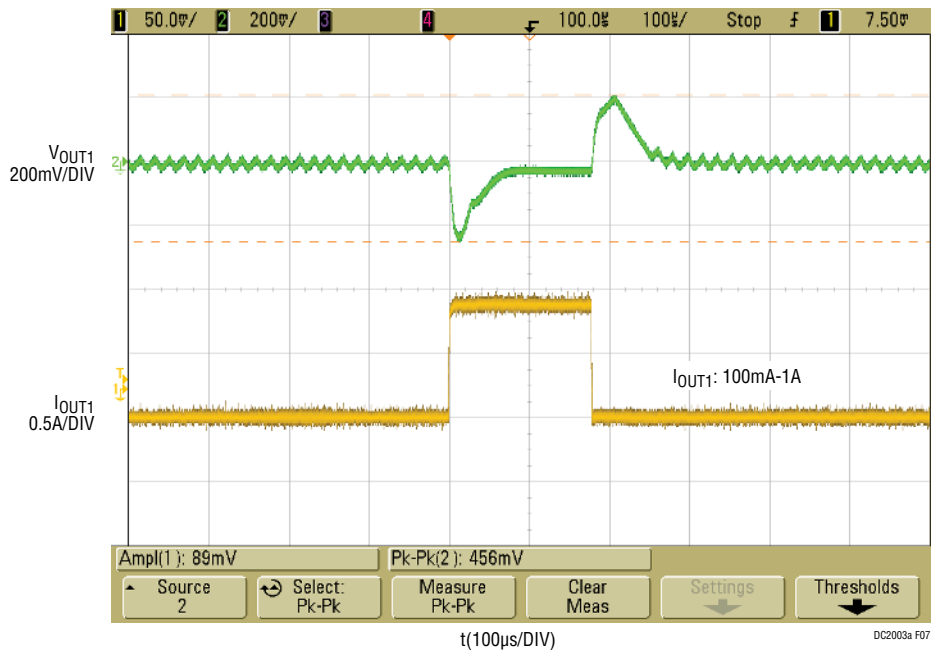

Figure 7. Load Transient Response at $V_{IN} = 12V$, $V_{OUT1} = 3.3V$, $I_{OUT1} = 100mA-1A$, $F_{SW} = 1MHz$, Burst Mode Operation

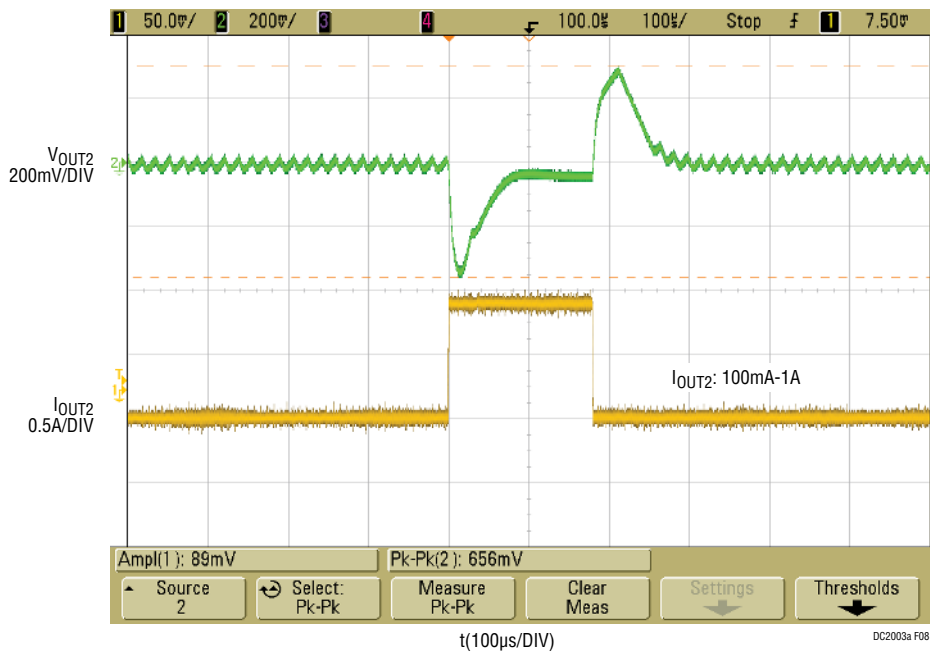

Figure 8. Load Transient Response at $V_{IN} = 12V$, $V_{OUT2} = 5V$, $I_{OUT2} = 100mA-1A$, $F_{SW} = 1MHz$, Burst Mode Operation

QUICK START PROCEDURE



Figure 9. Thermal Performance at $V_{IN} = 12V$, $V_{OUT1} = 3.3V$, $I_{OUT1} = 1A$, $V_{OUT2} = 5V$, $I_{OUT2} = 1A$, $F_{sw} = 1MHz$, No Airflow

DEMO MANUAL DC2003A

PARTS LIST

ITEM	QTY	REFERENCE	PART DESCRIPTION	MANUFACTURER/PART NUMBER
Required Circuit Components				
1	2	CFF1, CFF2	CAP, 0402 22pF 5% 50V NPO	AVX 04025A220JAT2A
2	2	CIN1, CIN2	CAP, 7343 22µF 20% 35V TANT	AVX TPSY226M035R0200
3	2	C1, C2	CAP, 1206 47µF 20% 16V X5R	TDK C3216X5R1C476M160AB
4	2	C5, C6	CAP, 1206 10µF 20% 25V X5R	TDK C3216X5R1E106M
5	1	C7	CAP, 0402 1µF 20% 10V X5R	TDK C1005X5R1A105M
6	1	L1	IND, 3.3µH 20%	COILCRAFT XFL4020-332MEC
7	1	L2	IND, 4.7µH 20%	COILCRAFT XFL4020-472MEC
8	2	RPG1, RPG2	RES, 0402 100kΩ 1% 1/16W	VISHAY CRCW0402100KFKED
9	3	RSET1, R1, RSET2	RES, 0402 619kΩ 1% 1/16W	VISHAY CRCW0402619KFKED
10	2	R2, R12	RES, 0402 309kΩ 1% 1/16W	VISHAY CRCW0402309KFKED
11	1	R3	RES, 0402 196kΩ 1% 1/16W	VISHAY CRCW0402196KFKED
12	2	R4, R13	RES, 0402 137kΩ 1% 1/16W	VISHAY CRCW0402137KFKED
13	1	R6	RES, 0805 0Ω JUMPER	VISHAY CRCW08050000Z0ED
14	2	R7, R8	RES, 0402 0Ω JUMPER	VISHAY CRCW04020000Z0ED
15	1	R11	RES, 0402 412kΩ 1% 1/16W	VISHAY CRCW0402412KFKED
16	1	R14	RES, 0402 84.5kΩ 1% 1/16W	VISHAY CRCW040284K5FKED
17	1	U1	IC, DUAL SYNCHRONOUS STEP-DOWN CONVERTER	LINEAR TECHNOLOGY LTC3622EDE
Additional Demo Board Circuit Components				
1	0	C3, C4	CAP, 0402 OPTION	OPTION
2	0	R5, R15	RES, 0402 OPTION	OPTION
Hardware: For Demo Board Only				
1	12	E1, E2, E3, E4, E5, E6, E7, E8, E9, E10, E11, E12	TURRET	MILL-MAX 2501-2-00-80-00-00-07-0
2	2	JP1, JP2	HEADER, 3PIN, 2mm	SULLINS NRPNO31PAEN-RC
3	2	JP3, JP5	HEADER, 3PIN, DBL ROW 2mm	SULLINS NRPNO32PAEN-RC
4	1	JP4	HEADER, 2mm DBL ROW (2X2) 4PIN	SULLINS NRPNO22PAEN-RC
5	10	JP6, JP7, JP8, JP9, JP10, JP11, JP12, JP13, JP14, JP15	HEADER, 2PIN, 2mm	SULLINS NRPNO21PAEN-RC
6	7	XJP1, XJP2, XJP3, XJP4, XJP5, XJP6, XJP13	SHUNT, 2mm	SAMTEC 2SN-BK-G
7	4	MH1, MH2, MH3, MH4	STANDOFF, SNAP ON	KEYSTONE_8831

SCHEMATIC DIAGRAM

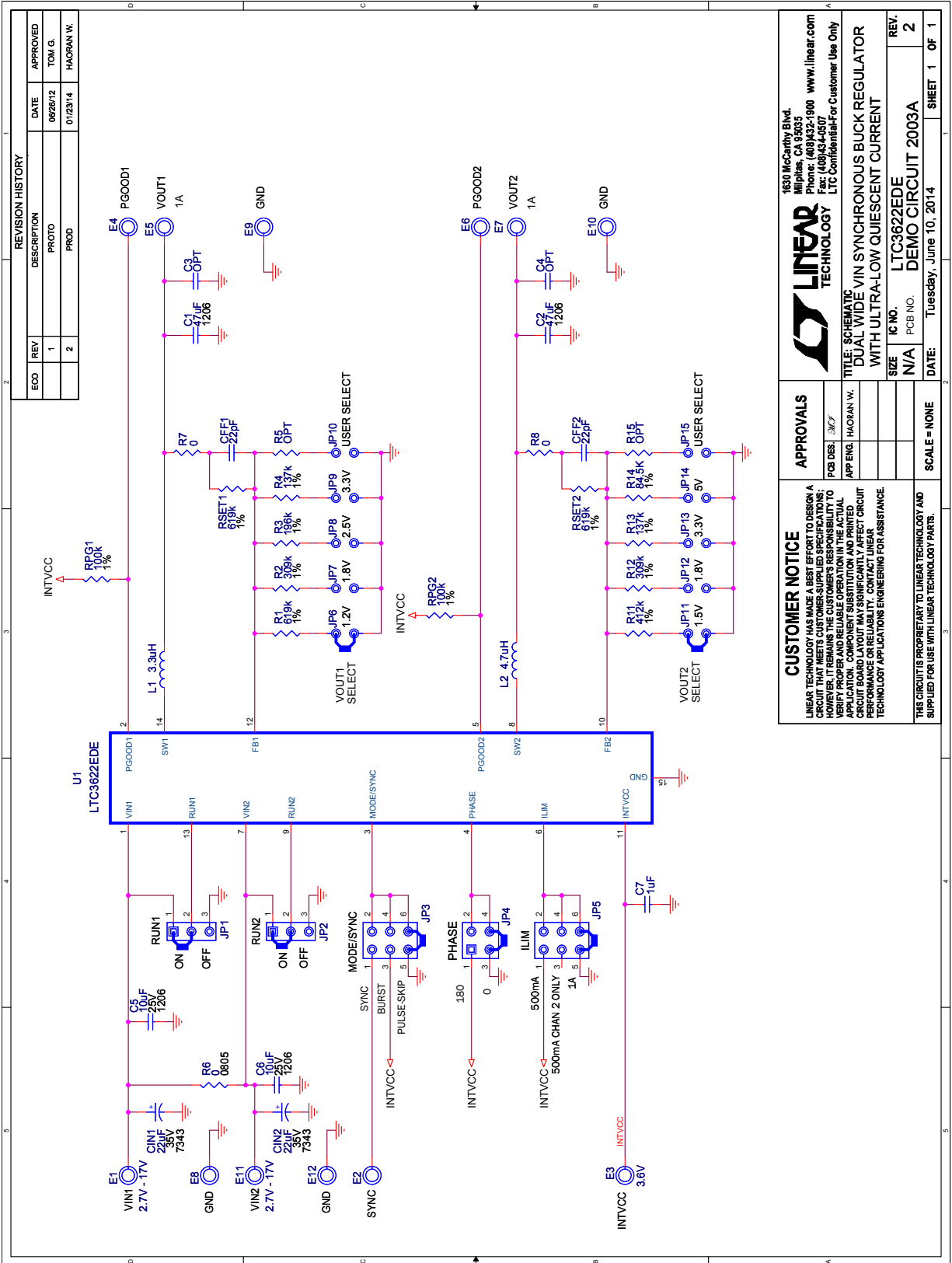

REVISION HISTORY				
ECO	REV	DESCRIPTION	DATE	APPROVED
	1		06/26/12	TOM G.
	2		01/23/14	HAORAN W.

1630 McCarty Blvd.
Milpitas, CA 95035
Phone: (408)323-1900 www.linear.com
Fax: (408)323-4507
LTC Confidential-For Customer Use Only

LINEAR TECHNOLOGY

TITLE: SCHEMATIC DUAL WIDE VIN SYNCHRONOUS BUCK REGULATOR WITH ULTRA-LOW QUIESCENT CURRENT

SIZE: N/A IC NO.: LTC3622EDE PCB NO.: DEMO CIRCUIT 2003A REV. 2

DATE: Tuesday, June 10, 2014 SHEET 1 OF 1

CUSTOMER NOTICE
LINEAR TECHNOLOGY HAS MADE A BEST EFFORT TO DESIGN A CIRCUIT THAT MEETS CUSTOMER-SUPPLIED SPECIFICATIONS; HOWEVER, IT REMAINS THE CUSTOMER'S RESPONSIBILITY TO VERIFY PROPER AND RELIABLE OPERATION IN THE ACTUAL APPLICATION. CUSTOMER SUBSTITUTION OF COMPONENTS ON THIS CIRCUIT BOARD, OR THE USE OF DIFFERENT CIRCUIT PERFORMANCE OR RELIABILITY. CONTACT LINEAR TECHNOLOGY APPLICATIONS ENGINEERING FOR ASSISTANCE.

APPROVALS
PCB DES: JCF
APP ENG: HAORAN W.

SCALE = NONE

THIS CIRCUIT IS PROPRIETARY TO LINEAR TECHNOLOGY AND SUPPLIED FOR USE WITH LINEAR TECHNOLOGY PARTS.

DEMO MANUAL DC2003A

DEMONSTRATION BOARD IMPORTANT NOTICE

Linear Technology Corporation (LTC) provides the enclosed product(s) under the following **AS IS** conditions:

This demonstration board (DEMO BOARD) kit being sold or provided by Linear Technology is intended for use for **ENGINEERING DEVELOPMENT OR EVALUATION PURPOSES ONLY** and is not provided by LTC for commercial use. As such, the DEMO BOARD herein may not be complete in terms of required design-, marketing-, and/or manufacturing-related protective considerations, including but not limited to product safety measures typically found in finished commercial goods. As a prototype, this product does not fall within the scope of the European Union directive on electromagnetic compatibility and therefore may or may not meet the technical requirements of the directive, or other regulations.

If this evaluation kit does not meet the specifications recited in the DEMO BOARD manual the kit may be returned within 30 days from the date of delivery for a full refund. **THE FOREGOING WARRANTY IS THE EXCLUSIVE WARRANTY MADE BY THE SELLER TO BUYER AND IS IN LIEU OF ALL OTHER WARRANTIES, EXPRESSED, IMPLIED, OR STATUTORY, INCLUDING ANY WARRANTY OF MERCHANTABILITY OR FITNESS FOR ANY PARTICULAR PURPOSE. EXCEPT TO THE EXTENT OF THIS INDEMNITY, NEITHER PARTY SHALL BE LIABLE TO THE OTHER FOR ANY INDIRECT, SPECIAL, INCIDENTAL, OR CONSEQUENTIAL DAMAGES.**

The user assumes all responsibility and liability for proper and safe handling of the goods. Further, the user releases LTC from all claims arising from the handling or use of the goods. Due to the open construction of the product, it is the user's responsibility to take any and all appropriate precautions with regard to electrostatic discharge. Also be aware that the products herein may not be regulatory compliant or agency certified (FCC, UL, CE, etc.).

No License is granted under any patent right or other intellectual property whatsoever. **LTC assumes no liability for applications assistance, customer product design, software performance, or infringement of patents or any other intellectual property rights of any kind.**

LTC currently services a variety of customers for products around the world, and therefore this transaction **is not exclusive**.

Please read the DEMO BOARD manual prior to handling the product. Persons handling this product must have electronics training and observe good laboratory practice standards. **Common sense is encouraged.**

This notice contains important safety information about temperatures and voltages. For further safety concerns, please contact a LTC application engineer.

Mailing Address:

Linear Technology
1630 McCarthy Blvd.
Milpitas, CA 95035

Copyright © 2004, Linear Technology Corporation